

INS/GPS Technology Trends

George T. Schmidt

Massachusetts Institute of Technology
10 Goffe Road
Lexington, MA 02421

Abstract

This paper focuses on accuracy and other technology trends for inertial sensors, Global Positioning Systems (GPS), and integrated Inertial Navigation System (INS)/GPS systems, including considerations of interference, that will lead to better than 1 meter accuracy navigation systems of the future. For inertial sensors, trend-setting sensor technologies will be described. A vision of the inertial sensor instrument field and strapdown inertial systems for the future is given. Planned accuracy improvements for GPS are described. The trend towards deep integration of INS/GPS is described, and the synergistic benefits are explored. Some examples of the effects of interference are described, and expected technology trends to improve system robustness are presented.

1.0 Introduction

Inertial navigation systems have progressed from the crude electromechanical devices that guided the early V-2 rockets (Figure 1a) to the current solid-state devices that are in many modern vehicles. The impetus for this significant progress came during the ballistic missile programs of the 1960s, in which the need for high accuracy at ranges of thousands of kilometers using autonomous navigation systems was apparent. By “autonomous” it is meant that no man-made signals from outside the vehicle are required to perform navigation. If no external man-made signals are required, then an enemy cannot jam them.

One of the early leaders in inertial navigation was the Massachusetts Institute of Technology (MIT) Instrumentation Laboratory (now Draper Laboratory), which was asked by the Air Force to develop inertial systems for the Thor and Titan missiles and by the Navy to develop an inertial system for the Polaris missile. This request was made after the Laboratory had demonstrated in 1953 the feasibility of autonomous all-inertial navigation for aircraft in a series of flight tests with a system called SPIRE (Space Inertial Reference Equipment), Figure 1b. This system had gimbals, was 5 feet in diameter and weighed 2700 pounds. The notable success of those early programs led to further application in aircraft, ships, missiles, and spacecraft such that inertial systems are now almost standard equipment in military and civilian navigation applications.

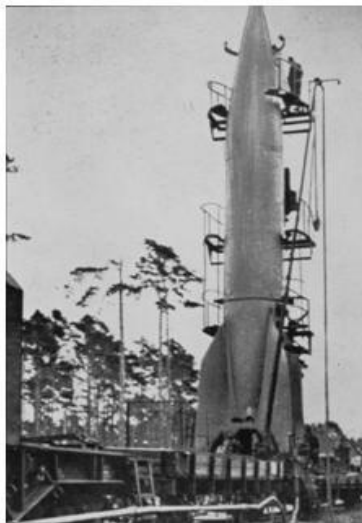

Figure 1a V-2 Rocket

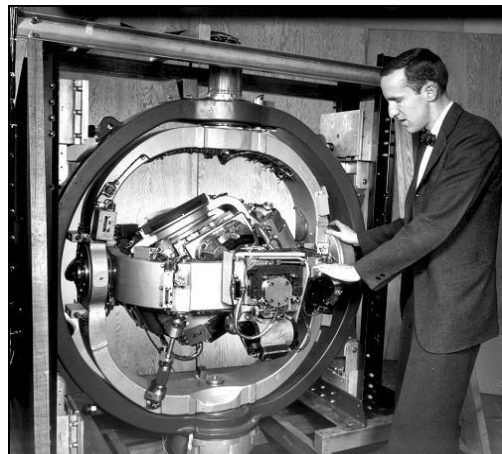

Figure 1b. SPIRE System

Inertial navigation systems do not indicate position perfectly because of errors in components (the gyroscopes and accelerometers) and errors in the model of the gravity field that the INS implements. Those errors cause the error in indicated position to grow with time. For vehicles with short flight times, such errors might be acceptable. For longer-duration missions, it is usually necessary to provide periodic updates to the navigation system such that the errors caused by the inertial system are reset as close to zero as possible. Because GPS offers world-wide, highly accurate position information at very low cost, it has rapidly become the primary aid to be used in updating inertial systems, at the penalty of using an aid that is vulnerable to interference. Clearly, the ideal situation would be low-cost but highly accurate INS that can do all, or almost all, of the mission without using GPS.

The military has had access to a specified accuracy of 21 m (95-percent probability) from the GPS Precise Positioning Service (PPS). This capability provides impressive worldwide navigation performance, especially when multiple GPS measurements are combined in a Kalman filter to update an INS on a military platform or a weapon. The Kalman filter provides an opportunity to calibrate some of the GPS errors, such as satellite clock and ephemeris errors, as well as several of the inertial system errors, and when properly implemented, Circular Error Probables (CEPs) better than 5m have been observed. In the near term, accuracies in the integrated navigation solution are predicted to improve to the 1 meter level. These accuracies will need to be available in the face of intentional interference of GPS, and the inertial system will provide autonomous navigation information during periods of GPS outage.

The following sections describe:

- The expected technology trends for inertial sensors and strapdown (no gimbals) systems that can support autonomous operation at low cost. Expectations are for strapdown INS/GPS systems that are smaller than 3 in³ and weigh less than a pound, and possibly cost under \$1000.
- Expected accuracy improvements and implementations for GPS.
- Issues and benefits of INS/GPS integration, particularly in an environment with interference.

The combination of a robust, anti-jam GPS receiver and an accurate, low-cost inertial system will provide the global precision navigation system of the future. Figure 2 depicts the “roadmap” to meeting this objective.

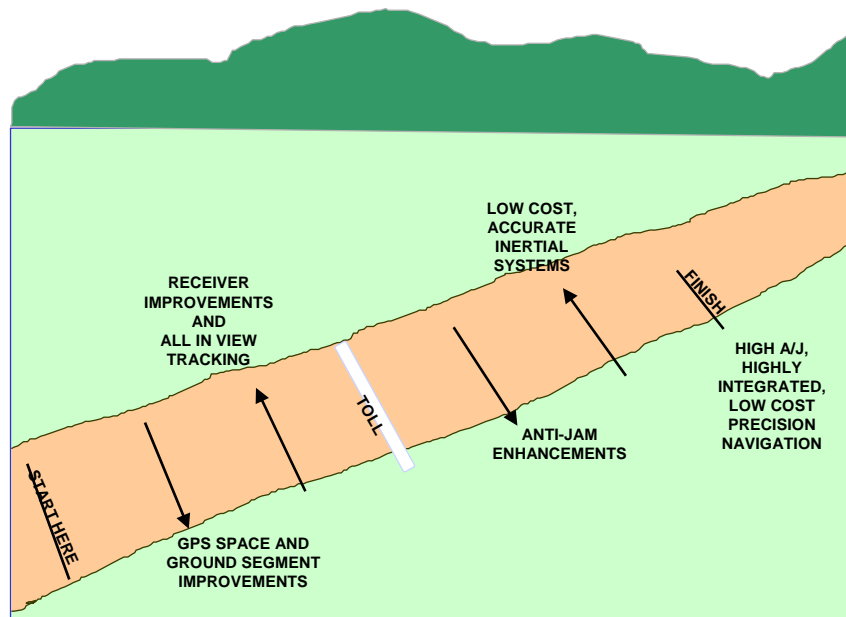

Figure 2. Roadmap to precision navigation for multiple applications.

2.0 Inertial Sensor Trends

The major error sources in the inertial navigation system are due to gyro and accelerometer inertial sensor imperfections, incorrect navigation system initialization, and imperfections in the gravity model used in the computations. But, in nearly all inertial navigation systems, the largest errors are due to the inertial sensors.

Whether the inertial sensor error is caused by internal mechanical imperfections, electronics errors, or other sources, the effect is to cause errors in the indicated outputs of these devices. For the gyros, the major errors are in measuring angular rates. For the accelerometers, the major errors are in measuring acceleration. For both instruments, the largest errors are usually a bias instability (measured in deg/hr for gyro bias drift, or micro g (μg) for the accelerometer bias), and scale-factor stability (which is usually measured in parts per million (ppm) of the sensed inertial quantity). The smaller the inertial sensor errors, the better the quality of the instruments, the improved accuracy of the resulting navigation solution, and the higher the cost of the system. As a “rule-of-thumb,” an inertial navigation system equipped with gyros whose bias stability is 0.01 deg/hr will see its navigation error grow at a rate of 1 nmi/hr of operation. The navigation performance requirements placed on the navigation system lead directly to the selection of specific inertial instruments in order to meet the mission requirements.

Figure 3, “Current Gyro Technology Applications,” gives a comprehensive view of the gyro bias and scale-factor stability requirements for various mission applications and what type of gyro is likely to be used in current applications (Figures 3 – 9 are revised versions of the figures in Ref. [1]).

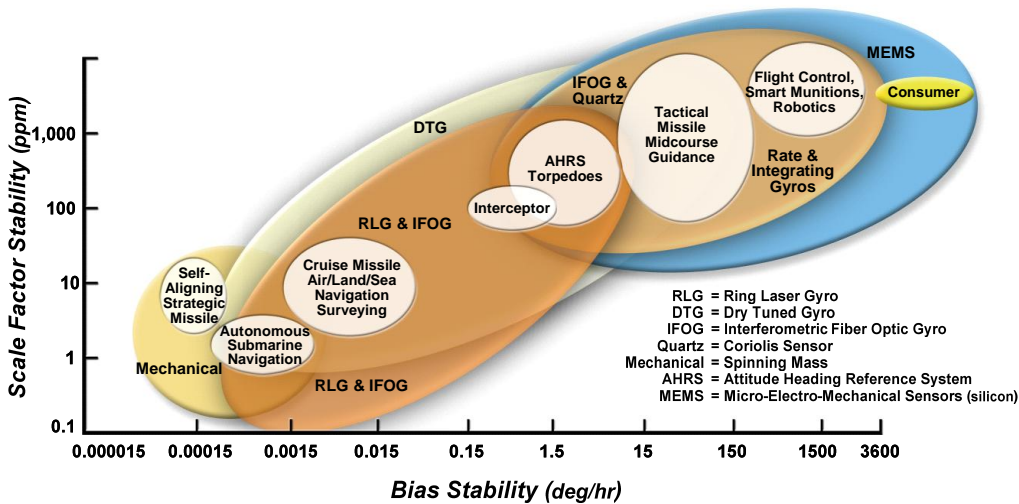

Figure 3. Current gyro technology applications.

Solid-state inertial sensors, such as Microelectromechanical System (MEMS) devices, have potentially significant cost, size, and weight advantages, which has resulted in a proliferation of the applications where such devices can be used in systems. While there are many conventional military applications, there are also many newer applications that will emerge with the low cost and very small size inherent in such sensors, particularly at the lower performance end of the spectrum. A vision of the gyro inertial instrument field for relevant military applications for the near-term is shown in Figure 4. Strapdown systems will also dominate.

The MEMS and Interferometric Fiber-Optic (IFOG) technologies are expected to replace many of the current systems using Ring Laser Gyros (RLGs) and mechanical instruments. However, one particular area where

the RLG is expected to retain its superiority over the IFOG is in applications requiring extremely high scale-factor stability. The change to all-MEMS technology hinges primarily on MEMS gyro development. The performance of MEMS instruments is continually improving, and they are currently being developed for many applications. This low cost can only be attained by leveraging off the consumer industry, which will provide the infrastructure for supplying the MEMS sensors in extremely large quantities (millions). The use of these techniques will result in low-cost, high-reliability, small-size, and lightweight inertial sensors and the systems into which they are integrated. The tactical (lower) performance end of the application spectrum will likely be dominated by micromechanical inertial sensors. The military market will push the development of these sensors for applications such as “competent” and “smart” munitions, aircraft and missile autopilots, short-time-of-flight tactical missile guidance, fire control systems, radar antenna motion compensation, “smart skins” using embedded inertial sensors, multiple intelligent small projectiles such as flechettes or even “bullets,” and wafer-scale INS/GPS systems.

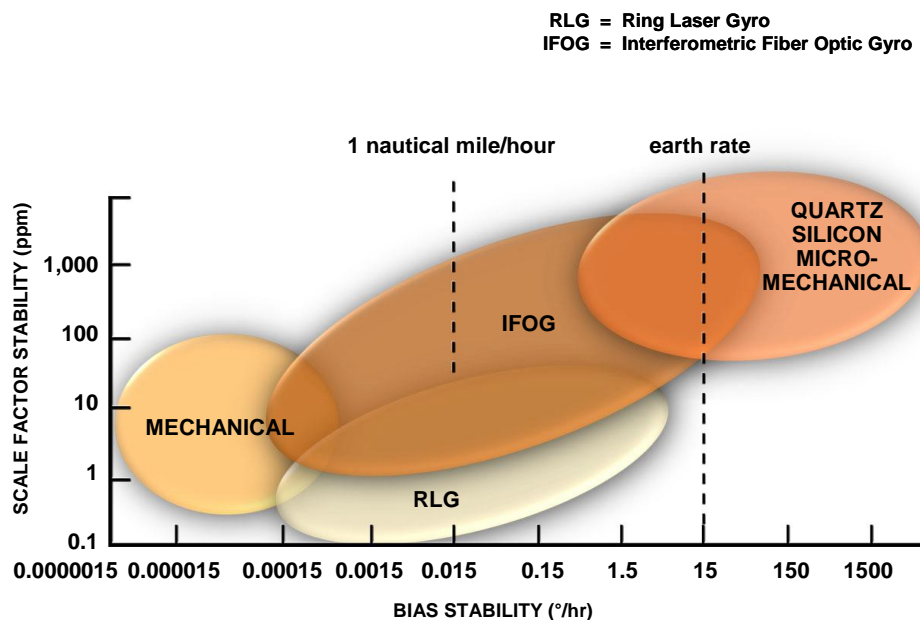

Figure 4. Near-term gyro technology applications.

Figure 5 shows how the gyro technology may possibly be applied to new applications in the far term. The figure shows that the MEMS and integrated-optics (IO) systems technology will dominate the entire low- and medium-performance range. The rationale behind this projection is based on two premises. The first is that gains in performance in the MEMS devices will continue with similar progression to the dramatic 3 to 4 orders-of-magnitude improvement that has already been accomplished in the last decade. That further improvements are likely is not unreasonable since the designers are beginning to understand the effects of geometry, size, electronics, and packaging on performance and reliability. Second, efforts are already underway to put all six sensors on one (or two) chips, which is the only way to reach a possible cost goal of less than \$1000 per INS/GPS system. In addition, since many of the MEMS devices are vibrating structures with a capacitive readout, this may restrict the performance gains. It is in this area that the integrated optics technology is most likely to be required to provide a true solid-state micromechanical gyro with optical readout. At this time, the technology to make a very small, accurate gyro does not exist, but advances in integrated optics are already under development in the communications industry. For the strategic application, the IFOG could become the dominant gyro. Work is underway now to develop radiation-hard IFOGs as well as super-high-performance IFOGs.

A potentially promising technology, which is in its infancy stages, is inertial sensing based upon atom interferometry (sometimes known as cold atom sensors). A typical atom de Broglie wavelength is 10^{-11} times smaller than an optical wavelength, and because atoms have mass and internal structure, atom interferometers are extremely sensitive. (Ref. [16]) Accelerations, rotations, electromagnetic fields, and interactions with other atoms change the atom interferometric fringes. This means that atom interferometers could make the most accurate gyroscopes, accelerometers, gravity gradiometers, and precision clocks, by orders of magnitude. If this far-term technology can be developed, then it could result in a 2 to 5-meter/hour navigation system without GPS, in which the accelerometers are also measuring gravity gradients.

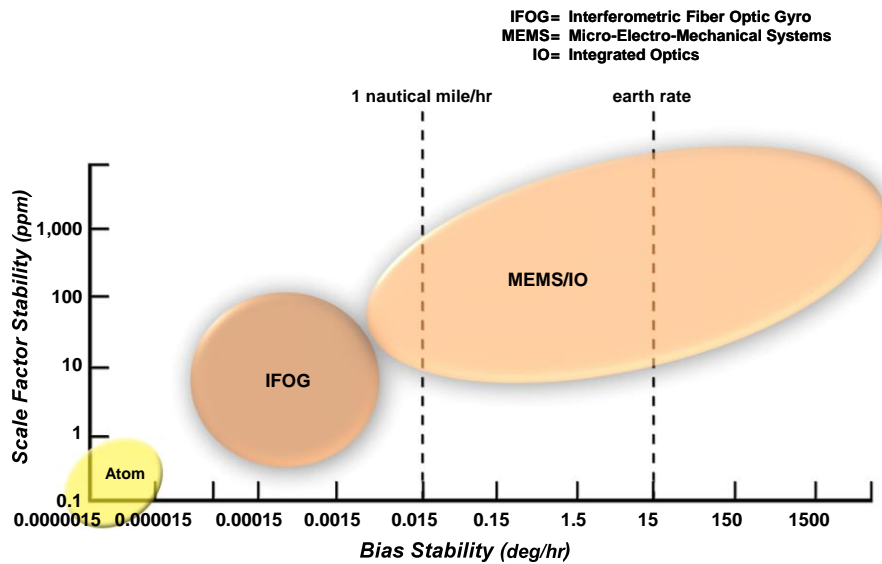

Figure 5. Far-term gyro technology applications.

Figure 6, “Current Accelerometer Technology Applications,” gives a comprehensive view of the accelerometer bias and scale-factor stability requirements for various mission applications and what type of accelerometer is likely to be used in current applications. “Mechanical Instruments” refers to the use of a Pendulous Integrating Gyro Assembly (PIGA) which is a mass unbalanced spinning gyroscope used to measure specific force.

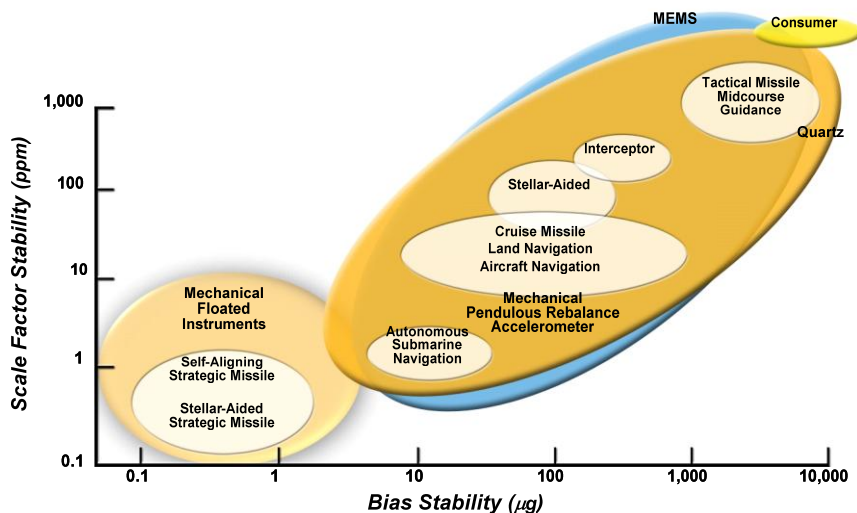

Figure 6. Current accelerometer technology applications.

Current applications are still dominated by electromechanical sensors, not only because they are generally low-cost for the performance required, but also because no challenging alternative technology has succeeded, except for quartz resonators, which are used in the lower-grade tactical and commercial applications. MEMS inertial sensors have not yet seriously broached the market, although they are on the verge of so doing, especially in consumer applications.

In the near-term (Figure 7), it is expected that the tactical (lower) performance end of the accelerometer application spectrum will be dominated by micromechanical accelerometers. As in the case for gyros, the military market will push the development of these sensors for applications such as “competent” and “smart” munitions, aircraft and missile autopilots, short-time-of-flight tactical missile guidance, fire control systems, radar antenna motion compensation, “smart skins” using embedded inertial sensors, multiple intelligent small projectiles such as flechettes or even “bullets,” and wafer-scale INS/GPS systems. Higher performance applications will continue to use mechanical accelerometers and possibly resonant accelerometers based on quartz or silicon. Quartz resonant accelerometers have proliferated widely into tactical and commercial (e.g., factory automation) applications. Silicon micromechanical resonator accelerometers are also being developed. Both of these technologies have possible performance improvements.

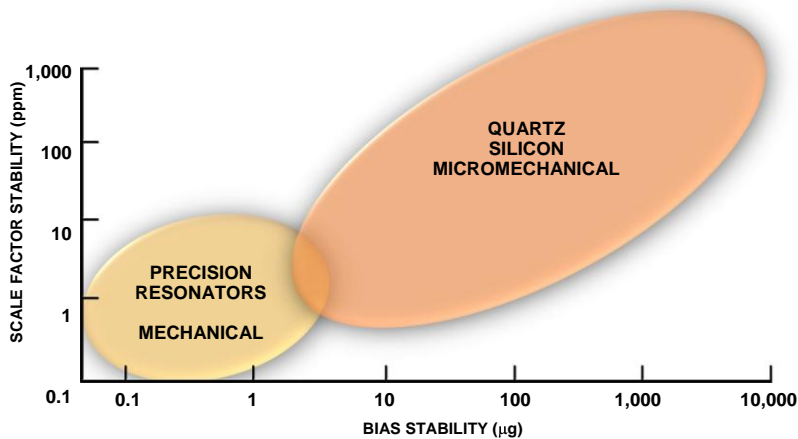

Figure 7. Near-term accelerometer technology applications.

Figure 8 shows how the accelerometer technology may be applied to new applications in the far term. As in the case of gyro projections for the future, the figure shows that the MEMS and integrated optics technology will dominate the entire low- and medium-performance range. The rationale behind this projection is based on exactly the same two premises as for the gyros. However, it is likely that the far-term accelerometer technology projections will be realized years sooner than the gyro.

Figure 9 shows INS or INS/GPS relative strapdown system cost “projections” as a function of inertial instrument technology and performance. The cost of a GPS receiver is likely to be so small that it will be insignificant. The systems are classified as: laser gyro or IFOG systems containing various types of accelerometer technologies; quartz systems with both quartz gyros and quartz accelerometers; and MEMS/integrated optics systems. The solid line indicates the range of approximate costs expected. Clearly, the quantity of systems produced affects the cost; large production quantities would be at the lower end of the cost range. The IFOG systems have the potential for lower cost than laser gyro systems because the IFOG should be well below the cost of an RLG. However, this has not happened to date, primarily because the RLG is in relatively large-volume production in well-facilitated factories and the IFOG is not yet manufactured in similar production quantities. Clearly, the MEMS/integrated optics INS/GPS systems offer the lowest cost. The ultimate low cost only becomes feasible in quantities of millions. This can be achieved only with multi-axis instrument clusters and on-chip or adjacent-chip electronics and batch packaging.

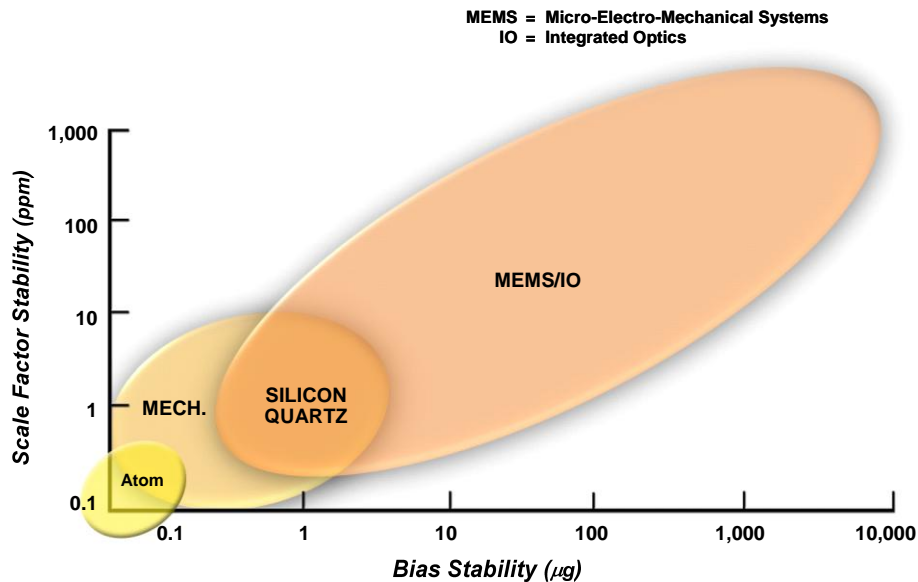

Figure 8. Far-term accelerometer technology applications.

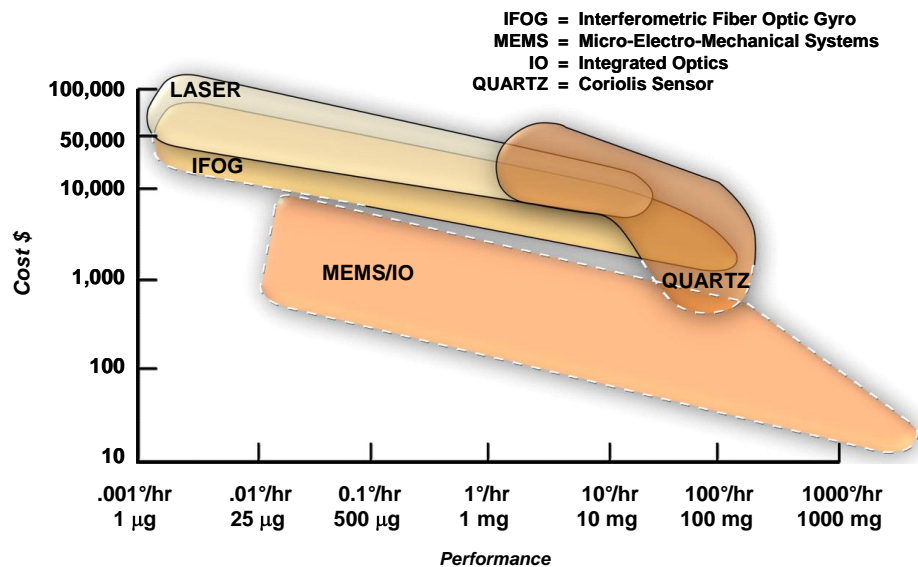

Figure 9. Strapdown INS cost as a function of instrument technology.

The ability of silicon-based MEMS devices to withstand high “g” forces has been demonstrated recently in a series of firings in artillery shells where the g forces reached over 6500 g. These small MEMS-based systems, illustrated in Figure 10, have provided proof-of-principal that highly integrated INS/GPS systems can be developed and led to a recent program where the goal was a system on the order of 3 in³, or 2 in³ for the INS alone (Ref. [2]). Unfortunately, the goals were not met. The current status of a typical MEMS INS is represented by the Honeywell HG1900 with a weight <1 lb., volume <20 cubic inches, power <3 watts, gyro bias of 1 to 30 °/hr, and gyro angle random walk of $0.1 \text{ } ^\circ/\sqrt{\text{hr}}$. This system is in production. Another is the HG1930 which has a volume of <4 cubic inches, a gyro bias of 20 °/hr and a gyro random walk of $0.15 \text{ deg}/\sqrt{\text{hr}}$ (Ref. [3]). The volumes compare with tactical grade RLG and IFOG systems with a volume of about 34in³. These systems also represent 4 orders of magnitude improvement in weight and volume over the gimbal system SPIRE. If micromechanical instrument performance improvements can be made, they will come to dominate the entire inertial instrument application spectrum.

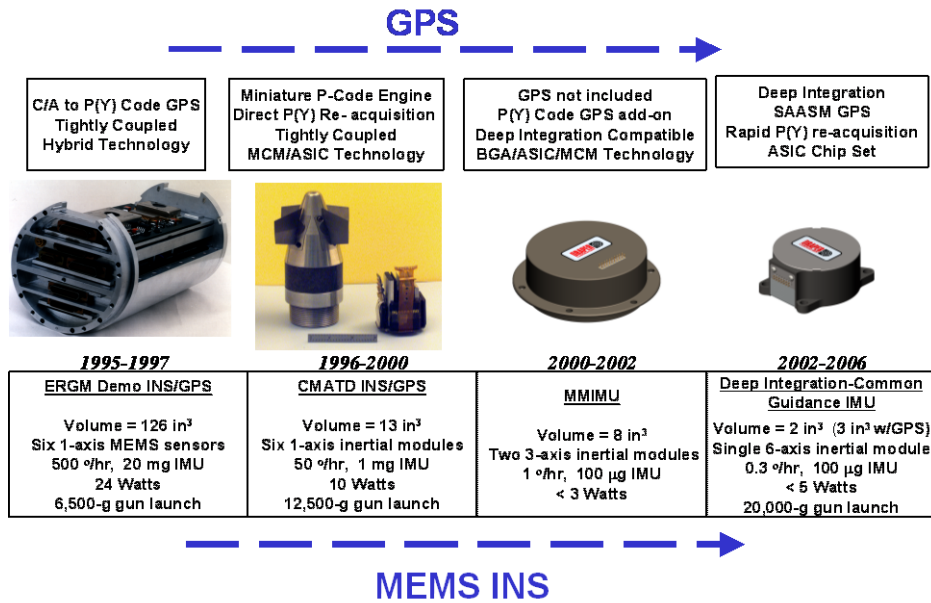

Figure 10. INS/GPS guidance system evolution.

3.0 GPS Accuracy and Other Improvements

The accuracy specification that is currently applicable to the GPS results in a precise positioning (PPS) of a GPS receiver operating with the military P(Y) code of approximately 10 m (CEP) in the WGS-84 coordinate system. Recent advances and programs to improve GPS accuracy have contributed to the real possibility of developing INS/GPS systems with smaller than 1-m CEP in the near term. This section will discuss these items.

The accuracy of the GPS PPS provides impressive navigation performance, especially when multiple GPS measurements are combined in a Kalman filter to update an INS. The Kalman filter provides an opportunity to calibrate the GPS errors, as well as the inertial errors, and when properly implemented, CEPs better than either system are achievable.

In assessing GPS accuracy in the mid 1990's, the largest error sources were in the space and control segment. The space segment dominant errors are: ionospheric errors, tropospheric errors, satellite clock errors, and satellite ephemeris with the latter two errors being dominant. The ionospheric errors can be reduced by using a two-frequency receiver (L_1 and L_2) and tropospheric errors can be reduced by using a deterministic compensation model. Table 1 gives a typical 1995 absolute GPS error budget (Ref. [4], p. 105). Horizontal Dilution of Precision (HDOP) is a geometrical factor that is a function of the geometry between the GPS receiver and the tracked satellites. For tracking four satellites, HDOP is typically 1.5. Then with a user equivalent range error (UERE) of 3.8m, and applying the approximate formula, $CEP = (0.83) (HDOP) (UERE)$, the resulting CEP is 4.7 m.

Table 1. “Typical” absolute GPS error budget. (circa 1995)

GPS Noise-Like Range Errors	1σ Values (m)
Multipath	0.6
Receiver noise	<u>0.3</u>
RMS noise-like error	0.7
GPS Bias-Like Range Errors	1σ Values (m)
Satellite ephemeris	1.4
Satellite clock	3.4
Atmospheric residual	<u>0.2</u>
RMS bias-like error	3.7
User equivalent range error (UERE) = $(0.7^2 + 3.7^2)^{1/2} = 3.8\text{m}$	
CEP = (0.83) (UERE) (HDOP) = 4.7m if HDOP = 1.5	

Beginning in the mid 1990’s various accuracy improvement programs were begun (Refs. [4] – [7]) to reduce the clock and ephemeris errors listed in Table 1. These errors can be reduced by sending more accurate and more frequent ephemeris and clock updates to the satellites from the control segment. In addition, if pseudorange corrections for all satellites are uploaded in each scheduled, individual satellite upload, then a PPS receiver can decode the messages from all satellites it is tracking and apply the most recent correction set. Increasing the upload frequency to three uploads per day for each satellite is expected to improve the combined error contribution of clock and ephemeris for PPS users by 50% by substantially decreasing the average latency of 11.5 hours in the data broadcast by the satellites.

In another phase of the program called the Accuracy Improvement Initiatives, the data from six National Geospatial Agency (NGA) GPS monitoring sites were integrated with data from the six existing Air Force monitoring sites in the operational control segment (OCS). By including additional data from the NGA sites, which are located at higher latitudes than the Air Force sites, an additional 15-percent improvement in combined clock and ephemeris accuracy is predicted. Improvements to the Kalman filter that is used in the ground control segment to process all the satellite tracking information can further reduce the errors by 15 percent. In addition, by incorporating better dynamical models in the filter, another 5-percent improvement may be anticipated. Table 2 summarizes these predicted accuracy improvements (Ref. [4], p. 102).

Table 2. Planned reduction of combined clock and ephemeris errors.

Enhancement	Anticipated Combined Clock and Ephemeris Error Improvement over Existing Combined Error of 3.7 m (1σ)
Correction Updates (50% reduction)	1.8 m
Additional Monitor Stations (additional 15% reduction)	1.5 m
Non partitioned Kalman Filter (additional 15% reduction)	1.3 m
Improved Dynamic Model (additional 5% reduction)	1.2 m

Figure 11 shows the additional six NGA sites added in the initial stages of the Accuracy Improvement Initiative. The final five NGA sites included were at even higher latitudes to provide even more tracking data and additionally provide triple ground station usability of every GPS satellite.

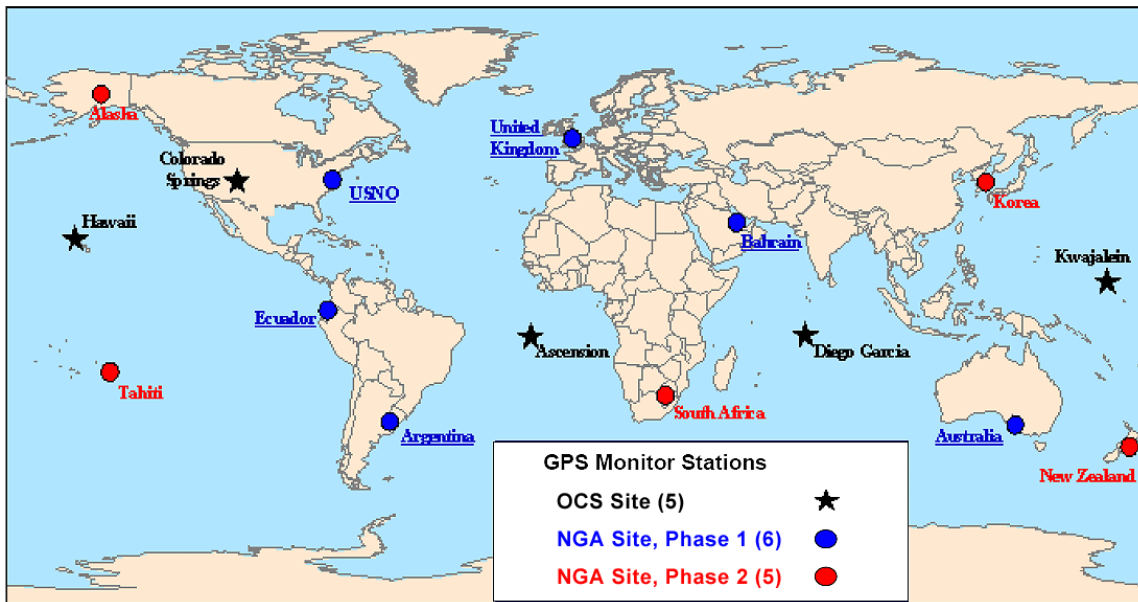

Figure 11. OCS and NGA Tracking Stations

Improvements in the GPS Master Station Control Segment software such as implementing a non-partitioned Kalman filter and improved dynamic models are presented in Figure 12.

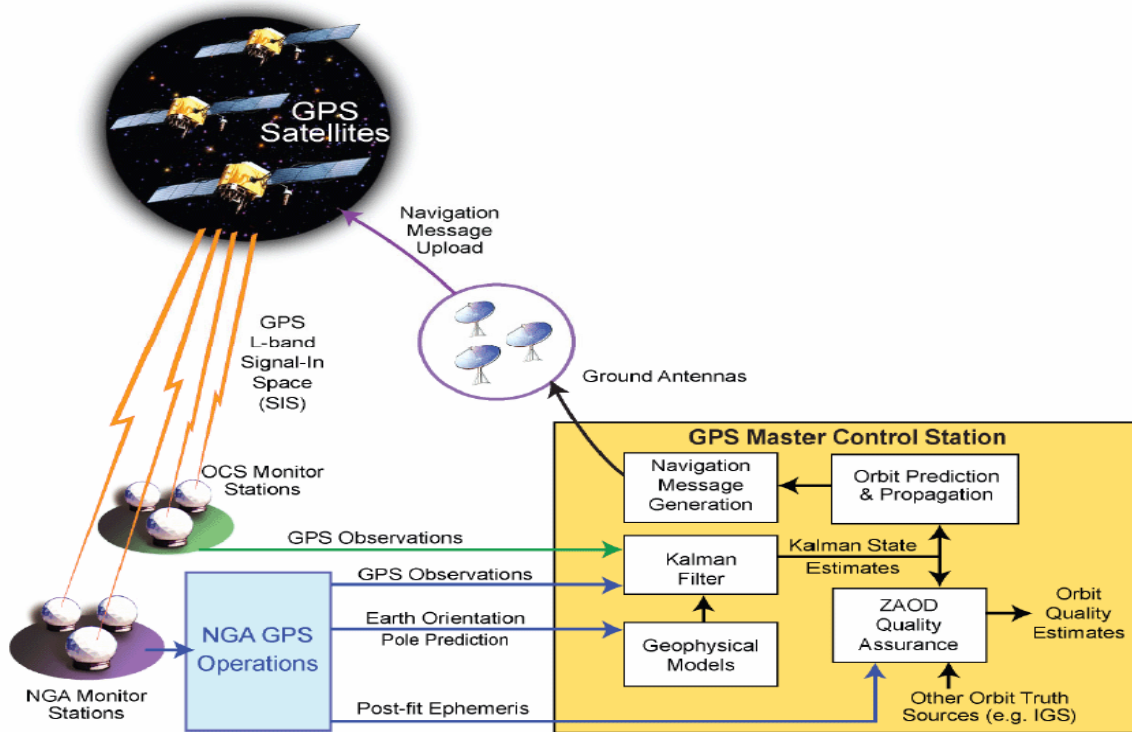

Figure 12. OCS Data Flow After Implementation of Accuracy Improvements

After all of these improvements, a ranging error on the order of 1.4 m is a reasonable possibility with the atmospheric residual unchanged. With all-in-view tracking (HDOP approximately 1.0), CEPs on the order of 1 m appear quite possible in the near term. $CEP = (0.83) (1.0) (1.4) = 1.1 \text{ m}$. If then, multiple GPS measurements are combined with an inertial system and Kalman Filter, better than 1 m accuracy should result.

To illustrate the benefits of the various GPS improvements, a simulation was conducted with an error model for a typical INS whose errors would result in 1.0 nmi/h error growth rate without GPS aiding. After 30 minutes of air vehicle flight including GPS updates every second, with all of the GPS accuracy improvements included, less than 1 meter CEP is obtained as shown in Table 3.

Table 3. Tightly coupled INS/GPS System-Air Vehicle Trajectory (@30 min).

CLOCK AND EPHEMERIS ERROR (1σ) ALL IN VIEW TRACKING	CEP (m) 8 SATELLITES
Current Model – 3.7 m	2.97 m
Correction Updates – 1.8 m	1.46 m
Additional Monitor Stations – 1.5 m	1.22 m
Non-partitioned Kalman Filter – 1.3 m	1.06 m
Improved Dynamic Model – 1.2 m	0.98 m

Another significant improvement in GPS for military systems will be the introduction of the M-code in GPS III, which is designed to be more secure and have better jamming resistance than the current Y code (Ref. [7]). The system is being designed such that a higher power signal (+20 dBW over current signal levels) will be available for localized coverage over an area of operations to boost signal jamming resistance. This significant improvement (M-code spot beam) is scheduled for the GPS-III phase of the GPS modernization process.

4.0 INS/GPS Integration

Many military inertial navigation systems could be replaced with less accurate inertial systems if it were guaranteed that GPS would be continuously available to update the inertial system to limit its error growth. A less accurate inertial system usually means a less costly system. However, given the uncertainty in the continuous availability of GPS in most military scenarios, an alternate way to reduce the avionics system cost is to attack the cost issue directly by developing lower-cost inertial sensors while improving their accuracy and low noise levels, as described in the “Inertial Sensor Trends” section. For applications without an interference threat, in the future, GPS updating is expected to provide better than 1-m navigation accuracy (CEP) when used in conjunction with an INS. The benefits and issues in using INS augmented with GPS updates, including a discussion of interference issues, have been presented in many references. Systems currently in use tend to be classified as either “the loosely coupled approach” or “the tightly coupled approach” (Figures 13 and 14 and Ref. [8]).

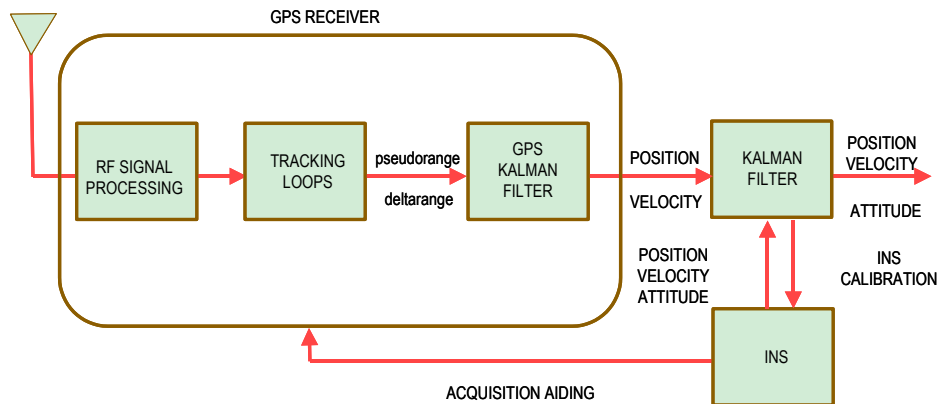

Figure 13. Loosely coupled approach.

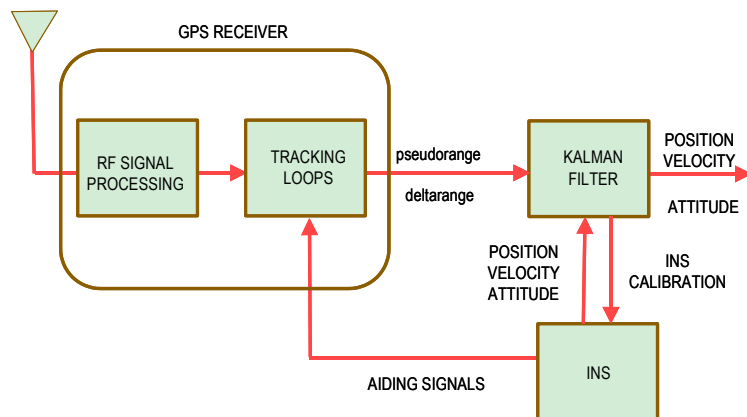

Figure 14. Tightly coupled approach.

The most recent research activity is a different approach called “deep integration” (Figure 15, Refs. ([9] and [10])). In this approach, the problem is formulated directly as an estimation problem in which the optimum (minimum-variance) solution is sought for each component of the multidimensional navigation state vector. By formulating the problem in this manner, the navigation algorithms are derived directly from the assumed dynamical models, measurement models, and noise models. The solutions that are obtained are not based on the usual notions of tracking loops and operational modes (e.g., State 3, State 5, etc.). Rather, the solution employs a nonlinear filter that operates efficiently at all jammer/signal (J/S) levels and is a significant departure from traditional extended Kalman filter designs. The navigator includes adaptive algorithms for estimating postcorrelation signal and noise power using the full correlator bank. Filter gains continuously adapt to changes in the J/S environment, and the error covariance propagation is driven directly by measurements to enhance robustness under high jamming conditions.

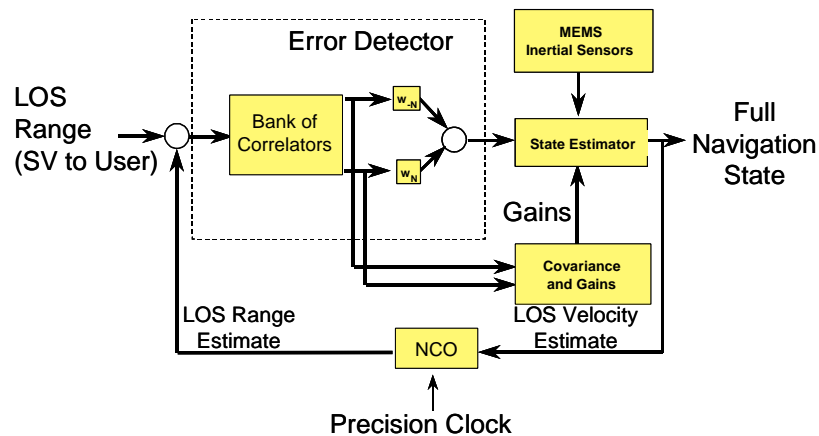

Figure 15. INS/GPS deep integration.

In this system, individual satellite phase detectors and tracking loop filters are eliminated. Measurements from all available satellites are processed sequentially and independently, and correlation among the line-of-sight distances to all satellites in view is fully accounted for. This minimizes problems associated with unmodeled satellite signal or ephemeris variations and allows for full Receiver Autonomous Integrity Monitoring (RAIM) capability.

Extended-range correlation may be included optionally to increase the code tracking loss-of-lock threshold under high jamming and high dynamic scenarios. If excessively high jamming levels are encountered (e.g., beyond 70-75 dB J/S at the receiver input for P(Y) code tracking), the GPS measurements may become so noisy that optimal weights given to the GPS measurements become negligible. In this situation, navigation error behavior is essentially governed by current velocity errors and the characteristics of any additional navigation sensors that are employed, such as an INS. Code tracking is maintained as long as the line-of-sight delay error remains within the maximum allowed by the correlator bank. If there is a subsequent reduction in J/S so that the optimal weights become significant, optimum code tracking performance is maintained without the need for reacquisition. Detector shapes for each correlator depend on the correlator lag and rms line-of-sight delay error.

Experiments have shown an improvement in code tracking of about 10 to 15 dB in wideband A/J capability for this architecture. Another 5 dB might be possible with data stripping to support extended predetection integration. Given that the implementation is done in software, it would be expected to be used in many future INS/GPS implementations. “Deep integration” is trademarked by the C.S. Draper Laboratory, Inc.

5.0 INS/GPS Interference Issues

Interference to the reception of GPS signals can be due to many causes such as telecommunication devices, local interference from signals or oscillators on the same platform, or possibly radar signals in nearby frequency bands. Attenuation of the GPS signal can be caused by trees, buildings, or antenna orientation, and result in reduced signal/noise ratio even without interference. This loss of signal can result in an increase in effective jammer/signal (J/S) level even without intentional jamming or interference. The minimum received signal power at the surface of the Earth is about -155dBW, a level easily overcome by a jammer source.

Military receivers are at risk due to intentional jamming. Jammers as small as 1 W located at 100 km from the receiver can possibly prevent a military receiver from acquiring the satellite signals and “locking-on” to C/A code. Representative jammers are shown in Figure 16. Larger jammers are good targets to find and to attack because of their large radiated power. Smaller jammers, which are hard to find, need to be defended against by improved anti-jam (A/J) technologies within the receiver, improved antennas, or by integration with an inertial navigation system. Proponents of high-accuracy inertial systems will generally argue that a high anti-jam GPS receiver is not required, while receiver proponents will argue that using a higher A/J receiver will substantially reduce inertial system accuracy requirements and cost. Both arguments depend entirely on the usually ill-defined mission and jamming scenario.

What has generally become accepted is that the GPS is remarkably vulnerable to jamming during the C/A code acquisition phase where conventional receiver technology has only limited jammer tolerability (J/S - 27 dB) (Refs. [10], [11], [12]). A 1-W (ERP) jammer located at 100 km from the GPS antenna terminals could prevent acquisition of the C/A code. Figure 17 is very useful in determining trade-offs between required A/J margin and jammer power. A 1-W jammer is “cheap” and potentially the size of a hockey puck. Furthermore, the C/A code can be spoofed by an even smaller power jammer. So generally, a GPS receiver cannot be expected to acquire the C/A code in a hostile environment.

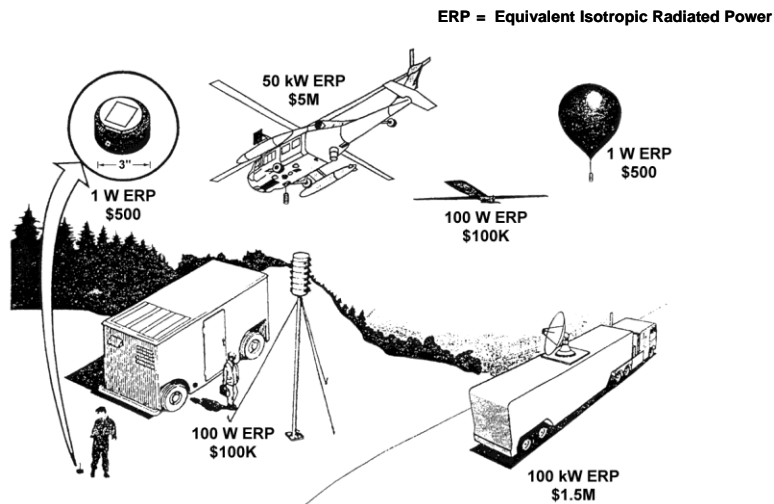

Figure 16. Jammer possibilities.

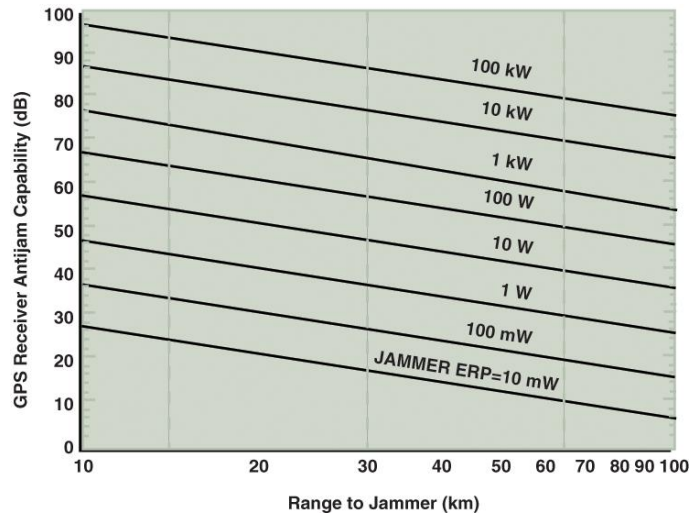

Figure 17. GPS jamming calculations.

For long-range cruise missile type applications, the C/A code could be acquired outside hostile territory and then the receiver would transition to P(Y) code lock, which has a higher level of jamming immunity. A 1-kW (ERP) jammer at about 100 km would now be required to break inertially-aided receiver code lock at 54 to 57 dB. As the weapon approaches the jammer, jammer power levels of about 10 W would be effective in breaking P(Y) code lock at 10 km (see Figure 18).

As previously mentioned, the “deep integration” architecture for combining INS and GPS may allow for tracking GPS satellites up to 70 – 75 dB J/S, an improvement of 15 to 20 dB above conventional P(Y) code tracking of 54 to 57 dB. If future increases of 20 dB in broadcast satellite power using the M-code spot beam (M spot) are also achieved, nearly 40 dB of additional performance margin would be achieved, so a jammer of nearly 100 kW would be required to break lock at 10 km. Furthermore, new receiver technology with advanced algorithms and space-time adaptive or nulling antenna technologies might also be incorporated into the system, further increasing its A/J capability significantly.

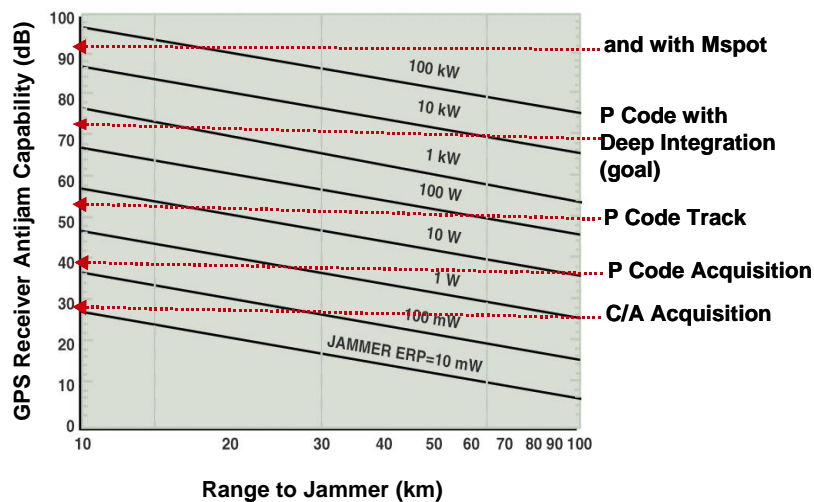

Figure 18. Possible A/J capabilities.

Recently (Ref. [3]) Honeywell and Rockwell Collins created a joint venture, Integrated Guidance Systems LLC, to market and produce a series of deep integration guidance systems. The IGS-200, for example, is G-hardened for artillery applications (15,750G), has a volume 16.5 in³, weighs < 1.25 lb., is based on the 1930G Honeywell MEMS IMU, and with deep integration and 2-channel digital nulling, the system supposedly has 80 – 90 dB J/S against a single jammer.

If A/J performance is increased significantly, then the jammer power must also be increased significantly. A large jammer would present an inviting target to an antiradiation, homing missile. In the terminal area of flight against a target, the jammer located at the target will eventually jam the receiver, and the vehicle will have to depend on inertial-only guidance or the use of a target sensor. Thus, it is important to ensure that accurate guidance and navigation capability is provided to meet military mission requirements against adversaries who are willing to invest in electronic countermeasures (ECM). This fact is true today and is expected to remain so in the foreseeable future. Figure 19 summarizes electronic counter-countermeasures (ECCM) techniques.

- **Lower Cost, High-Accuracy IMU's**
- **Improve Signals in Space**
 - Increased Accuracy
 - Mcode and Mspot
- **Improved Receivers**
 - Deep Integration With IMU
 - Anti-Spoof Techniques
 - Higher A/J Electronic
- **Direct P (Y) Code Acquisition, Lock-on Before Launch**
 - Improved Aircraft Interface To Munitions
 - Miniature On-board Clock
 - Multiple Correlators
- **Higher Performance, Lower Cost Adaptive Antennas**
 - Digital Beamforming
 - Modern Algorithms

Figure 19. Valuable ECCM technologies and techniques.

6.0 Concluding Remarks

Recent progress in INS/GPS technology has accelerated the potential use of these integrated systems, while awareness has also increased concerning GPS vulnerabilities to interference. Accuracy in the broadcast GPS signals will allow 1 meter INS/GPS accuracy. Many uses will be found for this high accuracy. In parallel, lower-cost inertial components will be developed and they will also have improved accuracy. Highly integrated A/J architectures for INS/GPS systems will become common, replacing avionics architectures based on functional black boxes where receivers and inertial systems are treated as stand-alone systems.

For future military and civilian applications, it is expected that the use of INS/GPS systems will proliferate and ultimately result in worldwide navigation accuracy better than 1 m, which will need to be maintained under all conditions. It can be expected that applications such as personal navigation systems, micro air vehicles (MAV), artillery shells, and automobiles will be quite common, see Figure 20. Other applications will certainly include spacecraft, aircraft, missiles, commercial vehicles, and consumer items.



Figure 20. Examples of potential applications.

Acknowledgments/Additional References

Thanks to Neil Barbour for assistance with the section on Inertial Sensor Trends. A history of inertial navigation is given in Ref. [14] and a history of the GPS program is given in Ref. [15].

References

- [1] Barbour, N. and Schmidt, G., "Inertial Sensor Technology Trends," *IEEE Sensors Journal*, Vol. 1, No. 4, 2001, pp. 332-339.
- [2] Anderson, R. et al. "Evolution of Low-Cost MEMS Inertial Systems," NATO RTO Symposium on *Military Capabilities Enabled by Advances in Navigation Sensors*, Istanbul, Turkey, October 2002.
- [3] Honeywell, Inc., "HG1900 MEMS IMU," DFOISR # 05-S-0725 and "HG1930 MEMS IMU," DFOISR 05-S-0723; and Integrated Guidance Systems LLC, "IGS-2xx series, deeply integrated guidance family," on www.igsllc.com.
- [4] National Research Council, *The Global Positioning System – A Shared National Asset*, National Academy Press, Washington, D.C., 1995.
- [5] Creel, et. al., "Summary of Accuracy Improvements from the GPS Legacy Accuracy Improvement Initiative (L-AII)," *ION GNSS 2007*, Ft. Worth, TX, September 2007.
- [6] McDonald, K. and Hegarty, C., "Post-Modernization GPS Performance Capabilities," *ION 56th Annual Meeting*, San Diego, CA, June 2000.
- [7] Fontana, R. and Latterman, D., "GPS Modernization and the Future," *ION 56th Annual Meeting*, San Diego, CA, June 2000. Also see *Aviation Week & Space Technology*, September 23, 2002, pp. 56-58.
- [8] Schmidt, G. and Phillips, R., "INS/GPS Integration Architectures," and "INS/GPS Integration Architecture Performance Comparisons" NATO RTO Lecture Series, RTO-EN-SET-116, *Low-Cost Navigation Sensors and Integration Technology*, October 2008.
- [9] Gustafson, D. et al., "A Deeply Integrated Adaptive GPS-Based Navigator with Extended Range Code Tracking," *IEEE Plans Conference*, San Diego, CA, March 2000. Also, see U.S. Patent 6,331,835 B1, December 18, 2001.

- [10] Gustafson, D. and Dowdle J., “Deeply Integrated Code Tracking: Comparative Performance Analysis,” *Institute of Navigation GPS/GNSS 2003*, Portland, OR, September 2003.
- [11] NAVSTAR-GPS Joint Program Office, *NAVSTAR GPS User Equipment*, February 1991.
- [12] Mahmood, S. et al., “Analysis of Differential Global Positioning System (DGPS) Techniques and GPS Jamming on Precision Guided Munition (PGM) Performance,” NATO/AGARD MSP Meeting, *Technologies for Precision Air Strike Operations in Rapid Reaction and Localized Conflict Scenarios*, Seville, Spain, October 1995.
- [13] Sklar, J., “GPS Capability Projections” in *Defense Science Board 1996 Summer Study Task Force on Tactics and Technology for 21st Century Military Superiority*, Vol. 3, October 1996, III.43-III.53.
- [14] Draper, C. S., “Origins of Inertial Navigation,” *Journal of Guidance and Control*, Vol. 4, No. 5, 1981, pp. 449-463.
- [15] Parkinson, B., “Origins, Evolution, and Future of Satellite Navigation,” *Journal of Guidance, Control, and Dynamics*, Vol. 20, No. 1, 1997, pp. 11-25.
- [16] Gustafson, T. et al., “Rotation Measurements with an Atom Interferometric Gyroscope,” *Physical Review Letters*, Vol. 78, No. 11, 17 March 1997, pp.2046-2049.

The interested reader is directed to books

Grewal and Andrews, Kalman Filtering, Wiley, 2008

Grewal, Weill, and Andrews, Global Positioning Systems, Inertial Navigation, and Integration, Wiley, 2007.

Bibliography of selected NATO AGARD and NATO RTO Reports

Leondes, C. T. (ed), *Theory and Applications of Kalman Filtering*, AGARDograph 139, 1970.

Schmidt, G. T. (ed), *Practical Aspects of Kalman Filtering Implementation*, AGARD Lecture Series No. 82, 1976.

Schmidt, G. T. (ed), *Strapdown Inertial Systems*, AGARD Lecture Series No. 95, 1978.

Schmidt, G. T. (ed), *Advances in Strapdown Inertial Systems*, AGARD Lecture Series No. 133, 1984.

Schmidt, G. T. (ed), *Kalman Filter integration of Modern Guidance and Navigation Systems*, AGARD Lecture Series No. 166, 1989.

Niemala, J. (ed), *Aerospace Navigation Systems*, AGARDograph 331, 1995.

Greenspan, R. (ed), *Innovative Applications of Satellite Navigation Systems*, AGARD Lecture Series No. 207, 1996.

Schmidt, G. T. (ed), *Advances in Navigation Sensors and Integration Technology*, RTO Lecture Series No. 232, 2003.

Savage, P. “Computational Elements for Strapdown Systems,” and “Performance Analysis of Strapdown Systems,” NATO RTO Lecture Series, RTO-EN-SET-116, *Low-Cost Navigation Sensors and Integration Technology*, October 2008.