

Designing with EMC in Mind

Controlling Interference on Multiple-Emitter Platforms

Thomas A. Jerse



The Boeing Company
Seattle, WA

Topics

- Multi-emitter platforms
- Interference model
- Transmitter and receiver characteristics
- Coupling model
- Margin calculation
- Nonlinear phenomena
- Mitigation techniques

Platforms



Interference Model

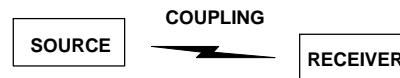

Interference Analysis

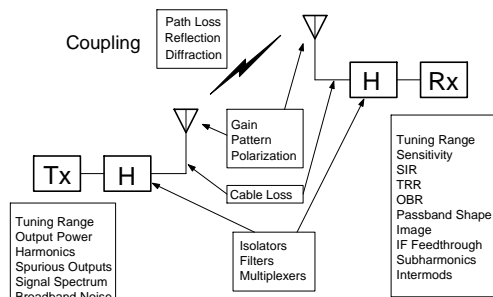

Receiver Specifications

- Damage level
- Sensitivity (MDS)
- Tolerance to interference (SIR)
- Tuning range rejection (TRR)
- Out-of-band rejection (OBR)
- Image rejection
- IF feedthrough
- LO leakage
- Subharmonic rejection
- Intermodulation intercept points

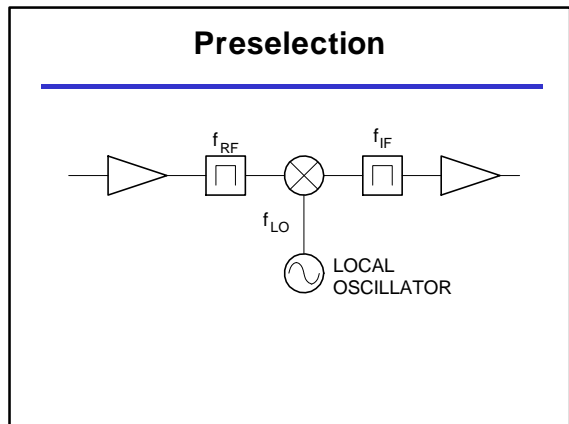
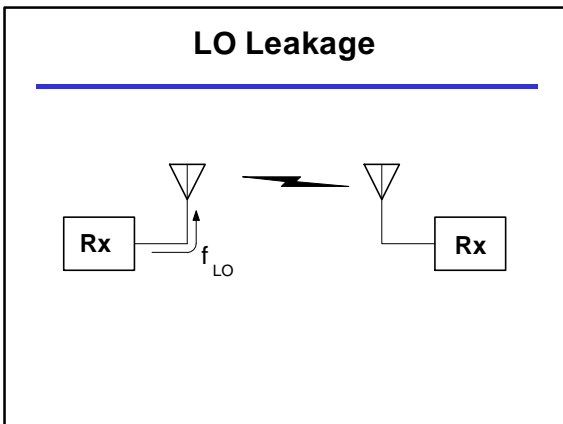
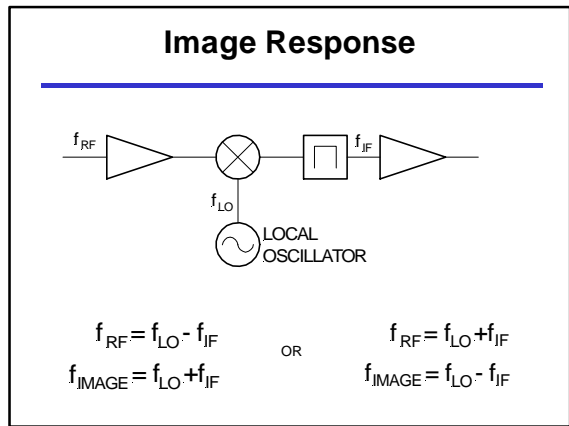
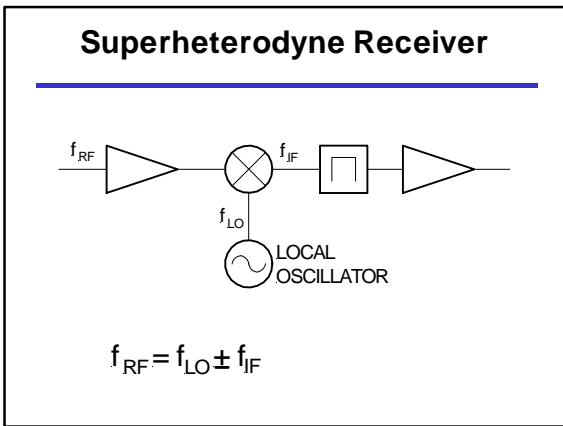
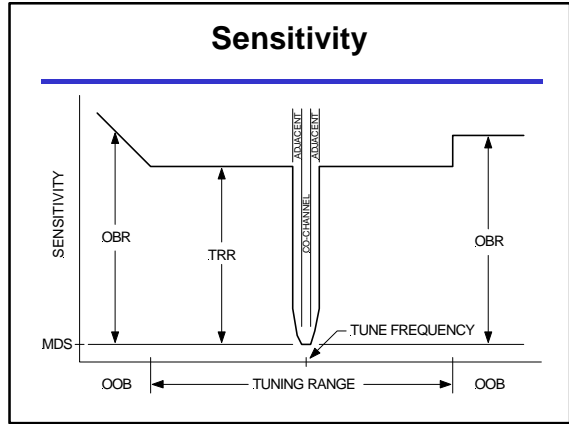
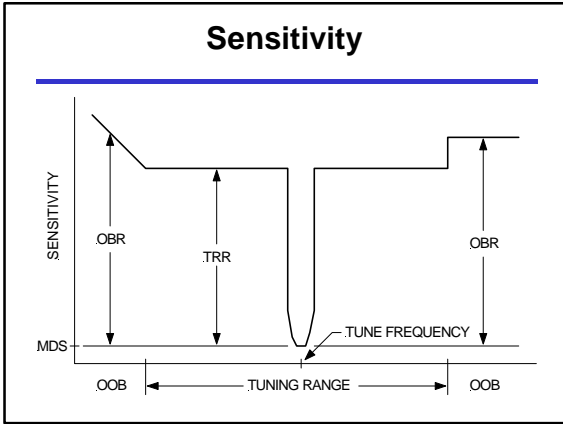

Rx Susceptibility

- Signal to Interference Ratio (SIR)
- Factors:
 - modulation type
 - detection method (algorithm)
 - SNR

Phase Detector Error

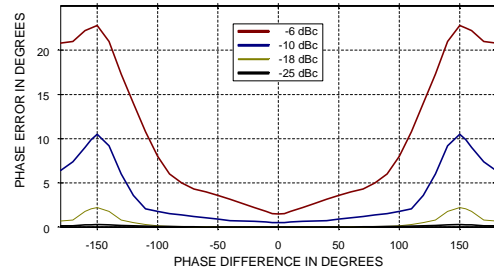

Effect of Interference

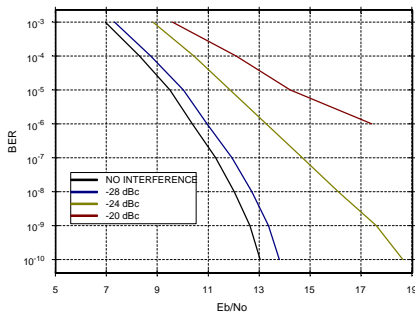

Interference Analysis

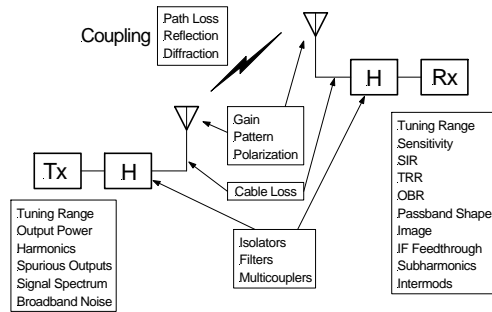

Transmitter Specifications

- Output power
- Harmonic outputs
- Spurious outputs
- Signal spectrum
- Broadband noise profile

Tx Harmonics

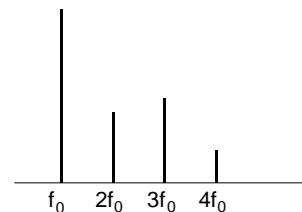

Other Tx Outputs

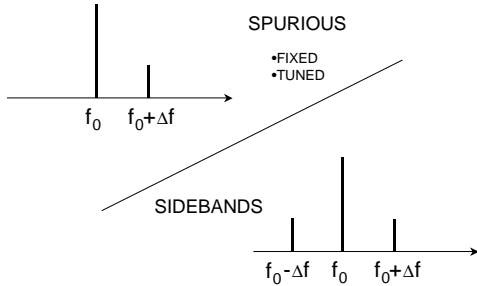

Tx Spectral Occupancy

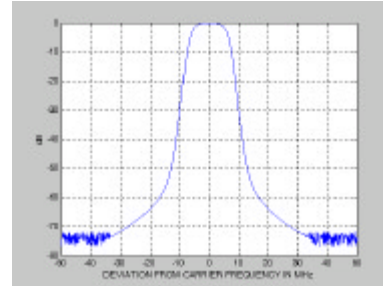

Transmitter Noise

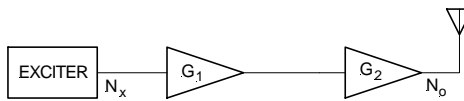

$$N_o = N_x + G_1 + G_2$$

Mid-Chain Filtering

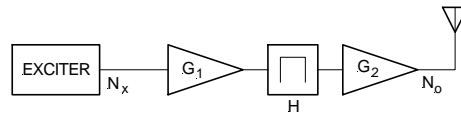

$$N_o = N_x + G_1 + H + G_2$$

Interference Analysis

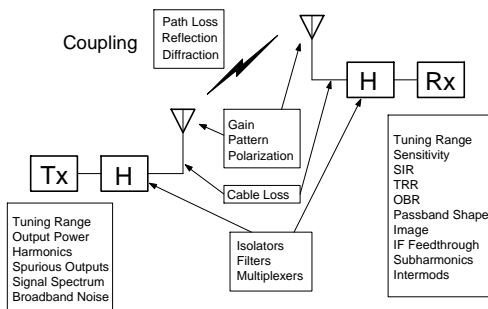

Coupling Factors

- Antenna characteristics
- Path loss
- Reflection
- Diffraction

Reciprocity

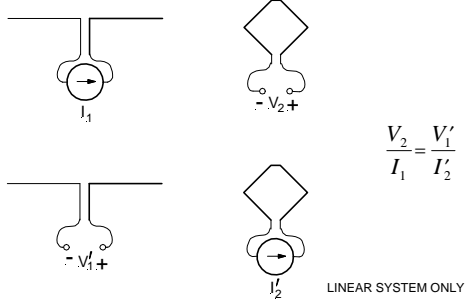

Antenna Parameters

- Directional gain
- Polarization
- Out-of-Band response

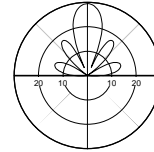

Zones

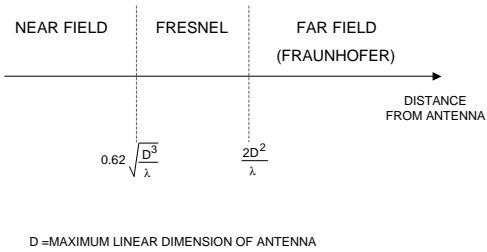

Friis Equation

FAR-FIELD

$$C = \frac{P_r}{P_t} = 20 \log_{10} \left(\frac{1}{4\pi R} \right) + G_{Tx} + G_{Rx} - L_{POL}$$

C = COUPLING IN dB

G = ANTENNA GAIN

R = SEPARATION DISTANCE

λ = WAVELENGTH

L_{POL} = CROSS-POLARIZATION LOSS

Path Loss

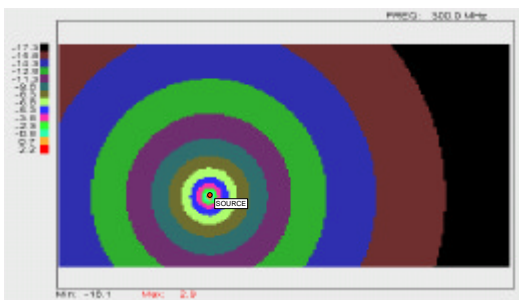

Reflections

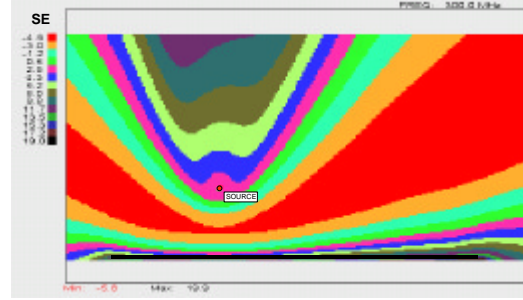

Diffraction and Reflection

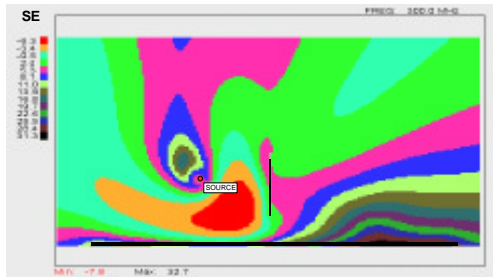

Modified Friis Equation

FAR-FIELD

$$C = \frac{P_r}{P_t} = 20 \log_{10} \left(\frac{1}{4\pi R} \right) + G_{Tx} + G_{Rx} - L_{POL} - SE$$

C = COUPLING IN dB G = ANTENNA GAIN

R = SEPARATION DISTANCE λ = WAVELENGTH

L_{POL} = CROSS-POLARIZATION LOSS

SE = SHIELDING EFFECTIVENESS

Interference Analysis

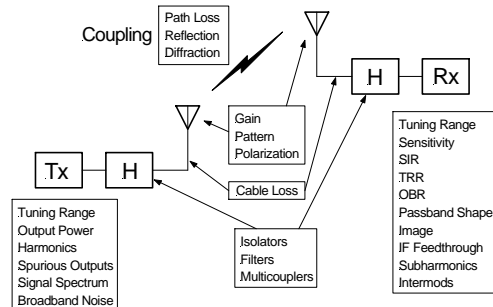

Linear Analysis

$$P_{Rx} = P_{Tx} + H_{Tx} - L_{CTx} + C - L_{CRx} + H_{Rx}$$

$$P_{Rx} < S_{Rx} - SIR - M$$

P _{Tx}	Tx POWER
H _{Tx}	Tx FILTER RESPONSE
L _{CTx}	Tx CABLE LOSS
C	COUPLING
L _{CRx}	Rx CABLE LOSS
H _{Rx}	Rx FILTER RESPONSE
S _{Rx}	Rx SENSITIVITY (MDS)
SIR	SIGNAL TO INTERFERENCE RATIO
M	MARGIN

Example

COUPLING

Tx Gain	2.1 dB
Rx Gain	2.1 dB
Path Loss	-34.0 dB
SE	10.0 dB
Polarization	0.0 dB
Net Coupling	-39.8 dB

Freq 328 MHz
λ 0.91 m
D 3.66 m

Rx POWER

Tx POWER	50.0 dBm
Tx FILTER	-0.5 dB
Tx CABLE	-0.3 dB
Coupling	-39.8 dB
Rx CABLE	-0.4 dB
Rx FILTER	-0.5 dB
Rx POWER	8.5 dBm

Rx SENS

MDS	-110 dBm @ Tune Freq
TRR	100 dB
MDS	-10 dBm @ Interference
SIR	10 dB
Limit	-20 dBm
Margin	-28.5 dB

Increased Separation

COUPLING

Tx Gain	2.1 dB
Rx Gain	2.1 dB
Path Loss	-62.5 dB
SE	10.0 dB
Polarization	0.0 dB
Net Coupling	-68.3 dB

Freq 328 MHz
λ 0.91 m
D 97.00 m

Rx POWER

Tx POWER	50.0 dBm
Tx FILTER	-0.5 dB
Tx CABLE	-0.3 dB
Coupling	-68.3 dB
Rx CABLE	-0.4 dB
Rx FILTER	-0.5 dB
Rx POWER	-20.0 dBm

Rx SENS

MDS	-110 dBm @ Tune Freq
TRR	100 dB
MDS	-10 dBm @ Interference
SIR	10 dB
Limit	-20 dBm
Margin	0.0 dB

Directional Antennas

COUPLING

Tx Gain	-12.1 dB
Rx Gain	-12.2 dB
Path Loss	-34.0 dB
SE	10.0 dB
Polarization	0.0 dB
Net Coupling	-68.3 dB

Freq 328 MHz
 λ 0.91 m
 D 3.66 m

Rx POWER

Tx POWER	50.0 dBm
Tx FILTER	-0.5 dB
Tx CABLE	-0.3 dB
Coupling	-68.3 dB
Rx CABLE	-0.4 dB
Rx FILTER	-0.5 dB
Rx POWER	-20.0 dBm

Rx SENS

MDS	-110 dBm @ Tune Freq
TRR	100 dB
MDS	-10 dBm @ Interference

SIR	10 dB
Limit	-20 dBm
Margin	0.0 dB

Rx Preselection

COUPLING

Tx Gain	2.1 dB
Rx Gain	2.1 dB
Path Loss	-34.0 dB
SE	10.0 dB
Polarization	0.0 dB
Net Coupling	-39.8 dB

Freq 328 MHz
 λ 0.91 m
 D 3.66 m

Rx POWER

Tx POWER	50.0 dBm
Tx FILTER	-0.5 dB
Tx CABLE	-0.3 dB
Coupling	-39.8 dB
Rx CABLE	-0.4 dB
Rx FILTER	-29.0 dB
Rx POWER	-20.0 dBm

Rx SENS

MDS	-110 dBm @ Tune Freq
TRR	100 dB
MDS	-10 dBm @ Interference

SIR	10 dB
Limit	-20 dBm
Margin	0.0 dB

Nonlinear Effects

- Front-end damage
- Subharmonic responses
- Intermodulation products
- Cross modulation
- Receiver desensitization

Subharmonic Response

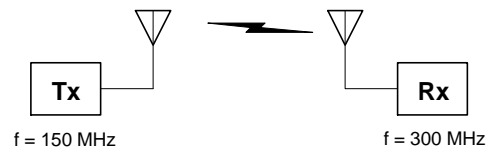

Subharmonics

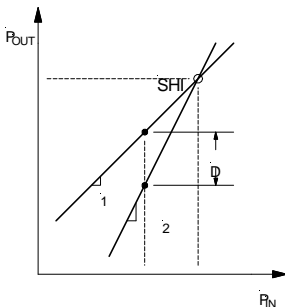

$$SHI = S + D$$

TO KEEP PRODUCT BELOW L dBm:

$$P_{in} < \frac{SHI + L}{2}$$

General Case

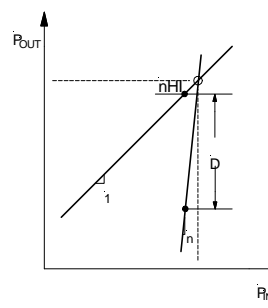

$$nHI = S + \frac{D}{n-1}$$

TO KEEP PRODUCT BELOW L dBm:

$$P_{in} < \frac{(n-1)nHI + L}{n}$$

Example

MDS	-110 dBm
SIR	10 dB
Max Interference	-120 dBm

HARMONIC NUMBER	HARMONIC INTERCEPT	MAX SIGNAL @ Rx INPUT
2	40 dBm	-40 dBm
3	45	-10
4	52	9
5	60	24

Preselection

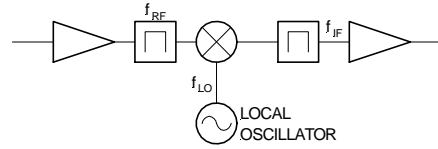

Intermodulation Products

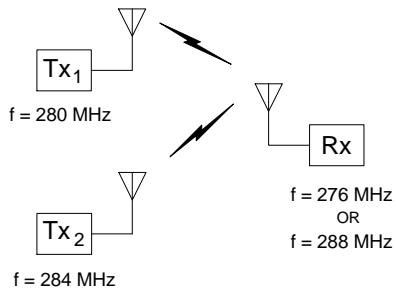

Intermodulation Products

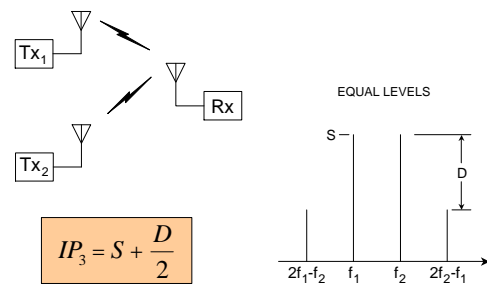

Intermodulation Products

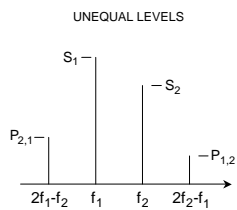

$$P_{2,1} = 2S_1 + S_2 - 2IP_3$$

$$P_{1,2} = S_1 + 2S_2 - 2IP_3$$

External IMD Generation

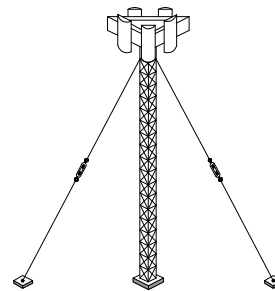

Re-radiated IMD

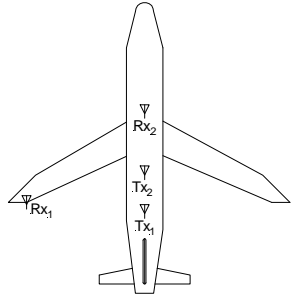

Cross Modulation

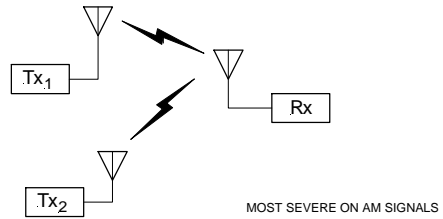

Tx Cross Modulation



Receiver Desensitization

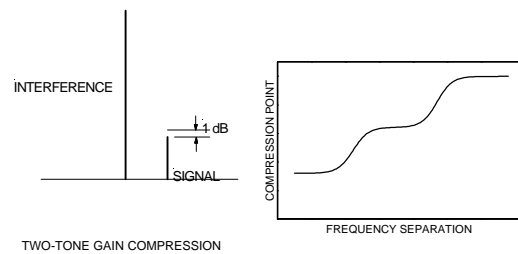

Mitigation Options

- Coupling reduction
- Filtering
- Tuning rules
- Blanking
- Statistical Characterization
- Active cancellation

Coupling Reduction

- Separation increase
- Absorber
- Cross polarization

Filtering

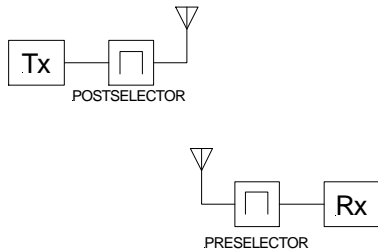

Mitigation Options

- Coupling reduction
- Filtering
- Tuning rules
- Blanking
- Statistical Characterization
- Active cancellation

Active Cancellation

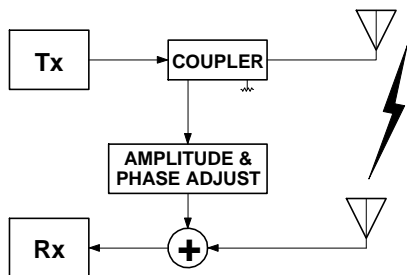

Accuracy Required

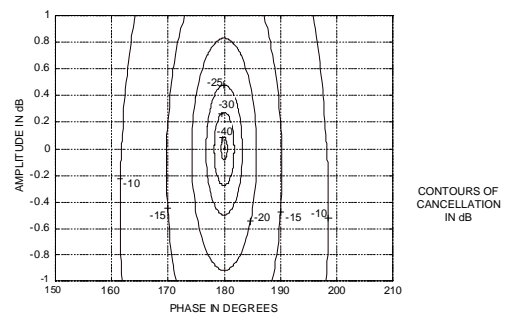

Summary of Concepts

- Interference analysis includes source and receiver parameters along with coupling factors.
- A thorough analysis involves a large number of combinations.
- Both linear and nonlinear effects are computed for the power delivered to the antenna terminals of the receiver.
- The Friis equation is used for the linear analysis of interference coupling.

Summary of Concepts

- Coupling can be estimated by summing path loss and shielding effectiveness.
- Intercept points are used to predict nonlinear products which can be produced by a variety of mechanisms.
- Mitigation techniques include filtering, coupling reduction, blanking, tuning rules, and active cancellation.