

Clark's Solar Energy System

An owner's report on a real photovoltaic
power system

“If you do the thing, you will have the power”

-- Ralph Waldo Emerson

by Clark Jones

One thing all computers more modern than the
Babbage Difference Engine require:

ELECTRIC POWER!

Presentation to IEEE Computer
Society, 6-Feb-2008

Clark's Solar Power System
Copyright © 2007-2008 by Clark Jones



Outline

- Overview of the system
 - Utility inter-tie versus stand alone
 - My system
- Utility rate plans
 - Net metering v. displaced generation cost
- Results from my system
- \$
- Reality
- Some related topics

Simplified Utility Inter-tie System

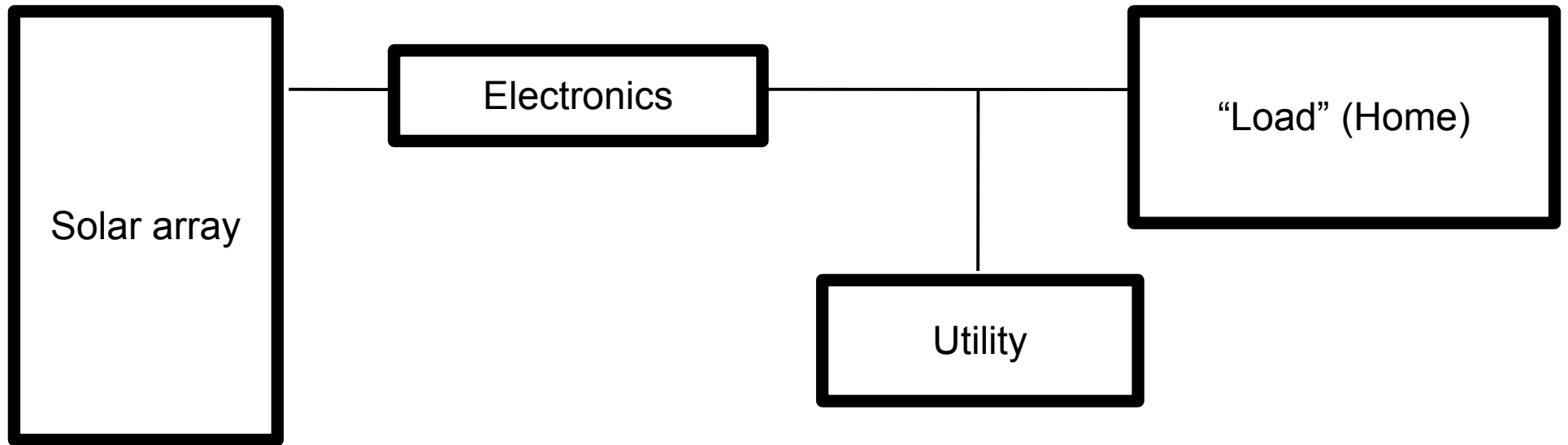

Simplified Stand-alone System

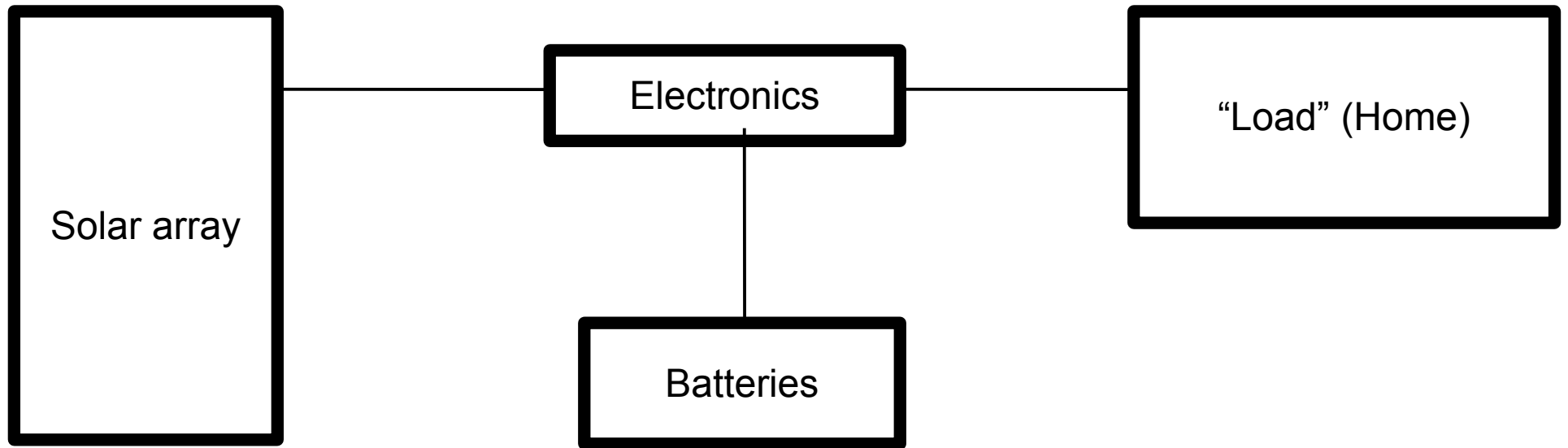

Utility Inter-tie v. Stand-alone

- NO BATTERIES!
- All power needed is available
- All power generated is used
- Low maintenance
- Does go down when power fails
- Batteries at ~\$50/kWhr
- Limited power/storage available
- High Maintenance
 - Monthly on batteries
 - Battery life ~5 years
- Doesn't fail when utility goes down

My System Specs

- 24 Kyocera modules rated 130 watts each
 - 10 square feet each, 240 square feet total
- Total: 3120 “nominal” watts (@25° C)
- Arranged in two panels of 12 modules each, mounted on two Zomeworks trackers
- Xantrex grid-connect inverter, rated 3300 watts
- Approximately 160' from the array to the inverter

Some Design Considerations

- Safety – Safety – Safety
 - Central to design of Inverter (electronics)
- Future remodel plans
 - Didn't want roof mount
- “Ease of use”
 - Low maintenance
- Life expectancy
 - 25 year warranty on modules ($\geq 80\%$ output)
 - Inverter 10+ years life expectancy

Inverter

- Converts DC to AC
- Safety
 - Monitors both DC and AC
 - DC monitored for ground faults
 - Grid power must be present & in-spec
 - Don't want to electrocute line workers!
 - Has to have stable power on both sides for 302 seconds
- Up to 95% efficient

Trackers in action

The “Electronics”

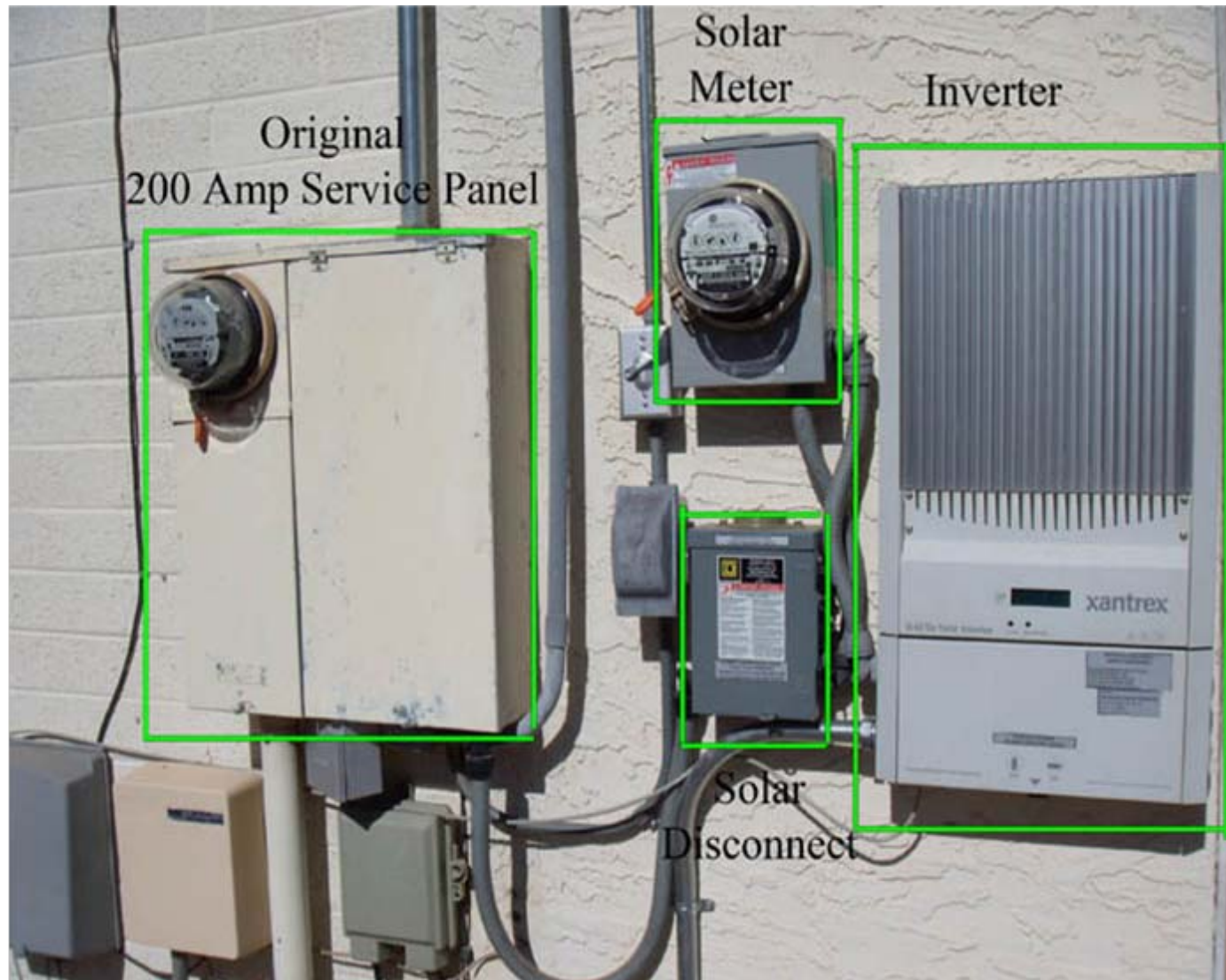

The LEAST Useful Number

- Homes require about 3 watts/sq ft, or 3%
- Worst modules in production ~5%
- Worst ever produced ~5%
- Mine are about 13%
- Interesting, useful number is \$ per watt

Utility Rate Plans

- Net Metering (SRP)
 - Regular meter “runs backwards” when generating more power than is being used
 - Surplus day power offsets night usage
 - If generation > use for month, get paid “displaced” price
- Displaced Generation Cost (APS)
 - More complex metering – measures all watts fed to grid, all used from grid
 - Paid “displaced generation cost” for every kWhr fed to grid (around 1.6¢/kWhr)

Utility Power Generation

- Many different “conventional” power sources
 - Hydroelectric
 - Nuclear
 - Coal-fired steam
 - Oil-fired steam
 - Gas-fired steam
 - Gas-turbine
 - Diesel Generators
- 
- Faster Starting*
(except Hydro)
- Higher Cost

Note: Gasoline generators cost ~ \$0.60 per kWhr just for gas!

Results From My System

- As of Feb. 4, 2008:
 - 8420 kWhr from Solar
 - 15520 kWhr from SRP
 - 23940 kWhr total usage
 - 35% from solar (since early August, 2006)

Actual Output from Inverter

kilwatt hours per day as of Monday 02-Apr-2007

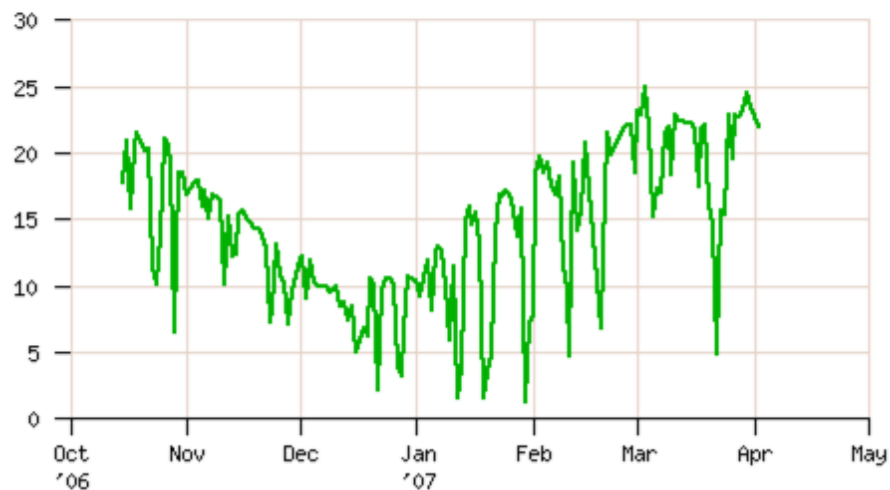

Inverter time on line per day (seconds) as of Monday 02-Apr-2007

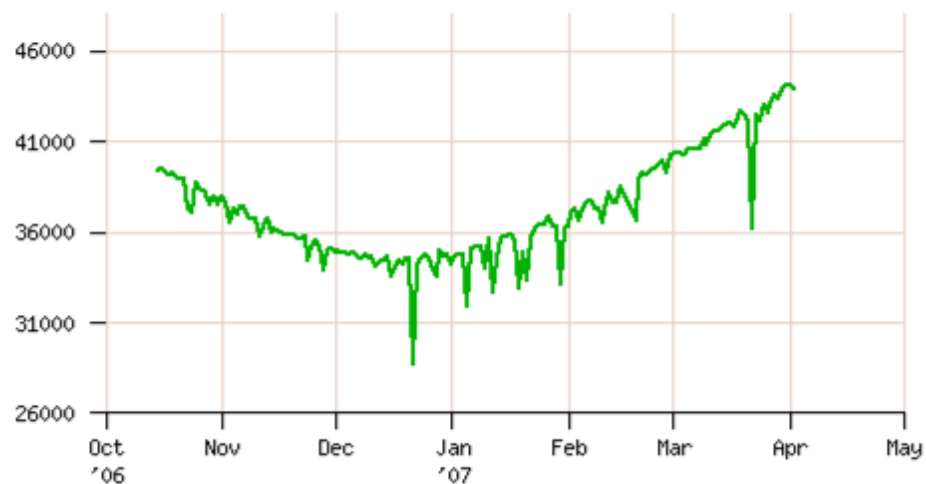

Example Output Curves

Tuesday, 27-Mar-2007 Total: 22.829 kWhr Online: 43042 sec

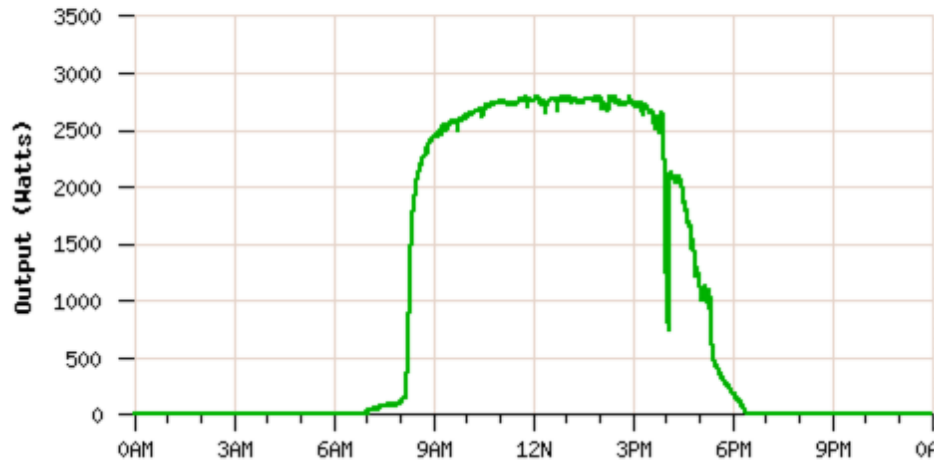

Wednesday, 28-Mar-2007 Total: 22.727 kWhr Online: 43549 sec

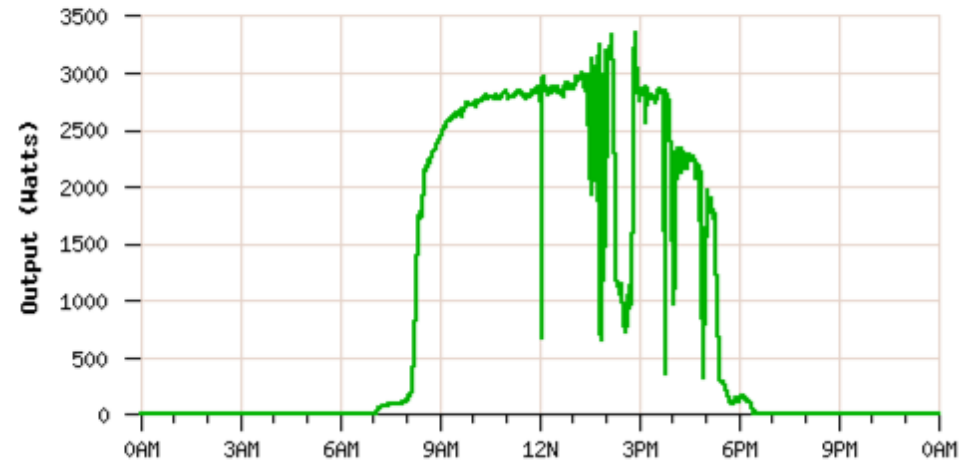

Tuesday, 30-Jan-2007 Total: 1.283 kWhr Online: 33058 sec



Why Below Nominal Output?

- Module temperature (rating at 25° C or 67° F)
- Clouds
- Haze or pollution
- Shading of modules
- Dirt, dust, bird droppings on modules
- A few things can increase output
 - Reflections off clouds
 - Snowpack (yeah, right – this IS Phoenix!!!)

Cost of System

24 Modules (130 watts each)	\$14,040
Inverter	\$2,173
Trackers & Poles	\$4,270
Installation labor	\$2,040
Other costs	\$2,077
Total	<hr/> \$24,600
Rebate (SRP)	-\$9,360
Tax (Federal)	-\$2,000
Tax (State)	-\$1,000
Net cost	<hr/> \$12,240

Yield

- Roughly 450kWhr per month
 - Summer rates ~\$45
 - Winter rates ~\$33
- Annual gross benefit expected: Roughly \$468
 - Remember maintenance, insurance, etc.
- That's less than 4% -- below CD rates!

Why Did I Do It?

- Global Warming over of Y2K?
 - A Convenient Lie?
 - Mars, Jupiter, Pluto also warming
- “Techie” appeal
- National Security – I can't go to war, but...
 - I've also decreased my gasoline usage by about 1/3
- Expect Increased Electric Costs
- Reduce pollution

Other Examples



Presentation to IEEE Computer Society, 6-Feb-2008

Clark's Solar Power System
Copyright © 2007-2008 by Clark Jones

Other Alternative Energy



Presentation to IEEE Computer
Society, 6-Feb-2008

Clark's Solar Power System
Copyright © 2007-2008 by Clark Jones

Typical power users in Phoenix

(All-electric home, no pool)

- Air conditioning/heating
- Hot water
- Fridge/freezer
- Everything else

Other comments

Manufacture of modules has increased an average of about 30% per year for the last 30 years!

Major manufacturers include major oil companies.

Meter Reading 101

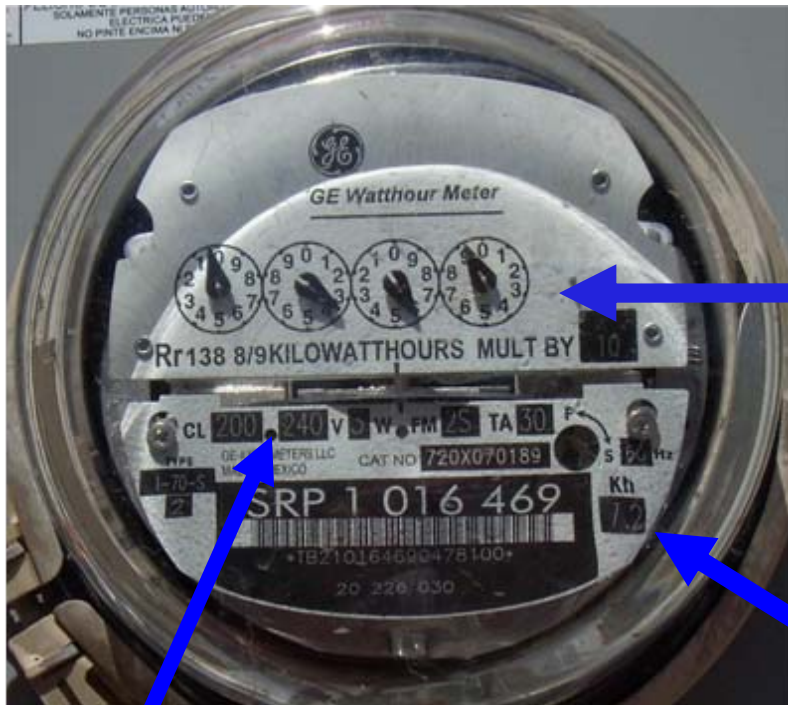

Dials turn in opposite directions!

Disk rotation shows energy usage (usually to right "+")

"Kh" number is number of watt-hours per disk rotation (usually 7.2 in USA)

Summary

- Solar generation of electricity is REAL
- It will work in the “suburbs”
- Everyone asks about “conversion efficiency”, when what they should be asking about is “cost efficiency”
- Can displace other energy sources

Some related resources

- “Kill-A-Watt” meters available at Ham Radio Outlet, on Dunlap just west of 19th Ave (south side of Dunlap)
- Dependable Solar Products, Inc. (installed my system): www.dependablesolarproducts.com
- Graphs made using Ploticus, ploticus.sf.net
- Presentation using “Impress”, OpenOffice.org