

Out-Of-Step Protection Fundamentals

Demetrios Tziouvaras

Schweitzer Engineering Laboratories, Inc.

IEEE PES San Francisco Chapter

December 13, 2007

Introduction

- The aim of this presentation is to explain
 - ◆ The fundamentals of out-of-step (OOS) protection
 - ◆ Discuss which relays and relay systems are prone to operate during **power swings**
 - ◆ Share experiences and lessons learnt from the past to avoid making the same mistakes

Introduction

- Interconnected systems experienced an increased number of large disturbances in the last 15 years
- Protective relay systems are often involved during major disturbances
 - ◆ In many cases they prevent further propagation of the disturbance
 - ◆ In some cases undesired relay operations have contributed to cascading blackouts

Outline

- Out of step (OOS) protection fundamentals
- Relay performance during OOS conditions
 - ◆ Transmission lines
 - ◆ Generators
- System design and protection improvements
- Conclusions

What Is a Power Swing?

- Variation of power flow which occurs when generator rotor angles are advancing or retarding relative to each other in response to:
 - ◆ System faults
 - ◆ Line switching
 - ◆ Major load switching
 - ◆ Loss of large generation
 - ◆ Major system disturbances

Stable and Unstable Power Swings

Definitions

- A power swing is considered stable if the generators do not slip poles and the system reaches a new state of equilibrium, i.e. an acceptable operating condition
- An unstable power swing results in a generator or group of generators experiencing pole slipping or loss-of-synchronism for which some corrective action must be taken.
 - ◆ Out-of-step is the same as an unstable power swing.

Power Swings can Cause Undesired Protective Relay Operation

- Power swings can cause undesired relay operation that may lead to:
 - ◆ Undesired tripping of power system elements at undesired network locations
 - ◆ Weakening of the power system
 - ◆ Possible cascading outages and shutdown of major portions of the power system
 - ◆ Damage of circuit breakers due to uncontrolled tripping
 - ◆ Loss of human life

Unstable Power Swings Damage System Integrity

- Pole slipping may damage generators and turbines
- Low voltage conditions experienced during unstable power swings may cause:
 - ◆ Motor stalling
 - ◆ Generator tripping
 - ◆ Damage to voltage-sensitive loads
- Prolonged low voltages could cause instability of smaller areas within a utility's system

Need for Out-of-Step Protection

- Generators operating asynchronously with the rest of the power system cannot regain stability as a result of any excitation or regulator action
- Asynchronous power system areas must be separated in a controlled fashion to avoid:
 - ◆ Equipment damage
 - ◆ Widespread outages in the power system

Philosophy of Power-Swing Protection

- Detect both stable and unstable power swings
- Block tripping of relay elements prone to operate during power swings
- Differentiate between stable and unstable power swings
- Separate the system into islands during out-of-step conditions

Philosophy of Power-Swing Protection

- Separate the system at locations that provide good balance of load/generation in the resulting system islands
- Trip only at pre-selected network locations and block tripping at all other locations
- Trip only under controlled transient recovery voltages or with low current

Power System Stability

Brief Review

Power System Stability

Definition

The ability of the electric power system to regain a state of operating equilibrium after being subjected to disturbances such as faults, line switching, load rejection, loss-of-excitation, and loss of generation.

Power Flow

Two-Machine System

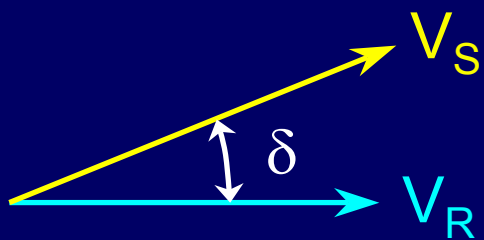
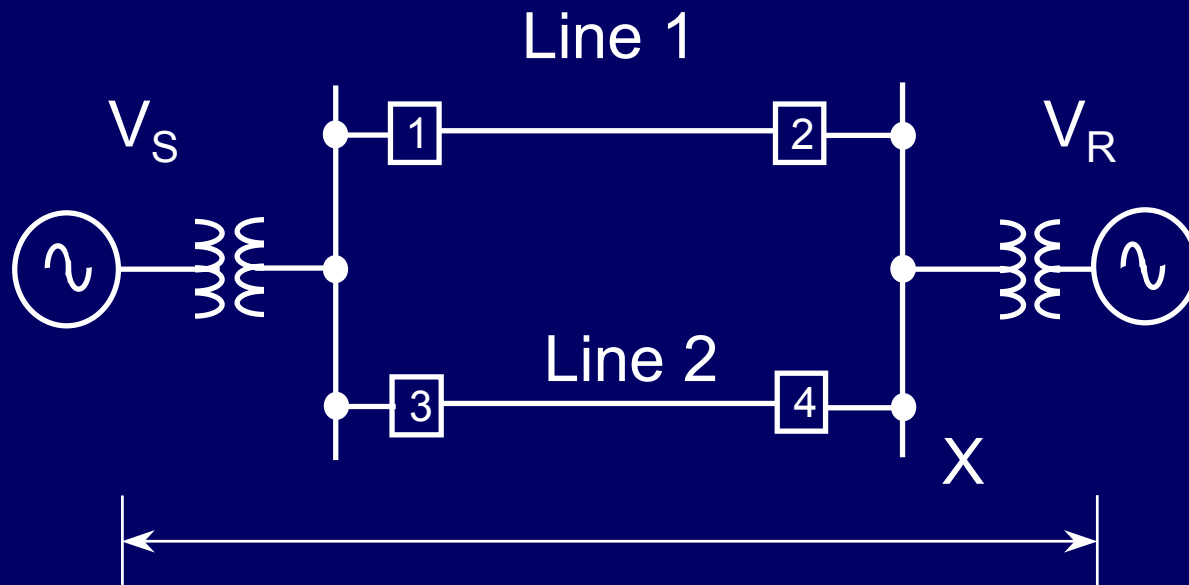

$$P = \frac{|V_S| \cdot |V_R|}{|X|} \sin \delta$$

Effect of Fault Type on Power Transfer

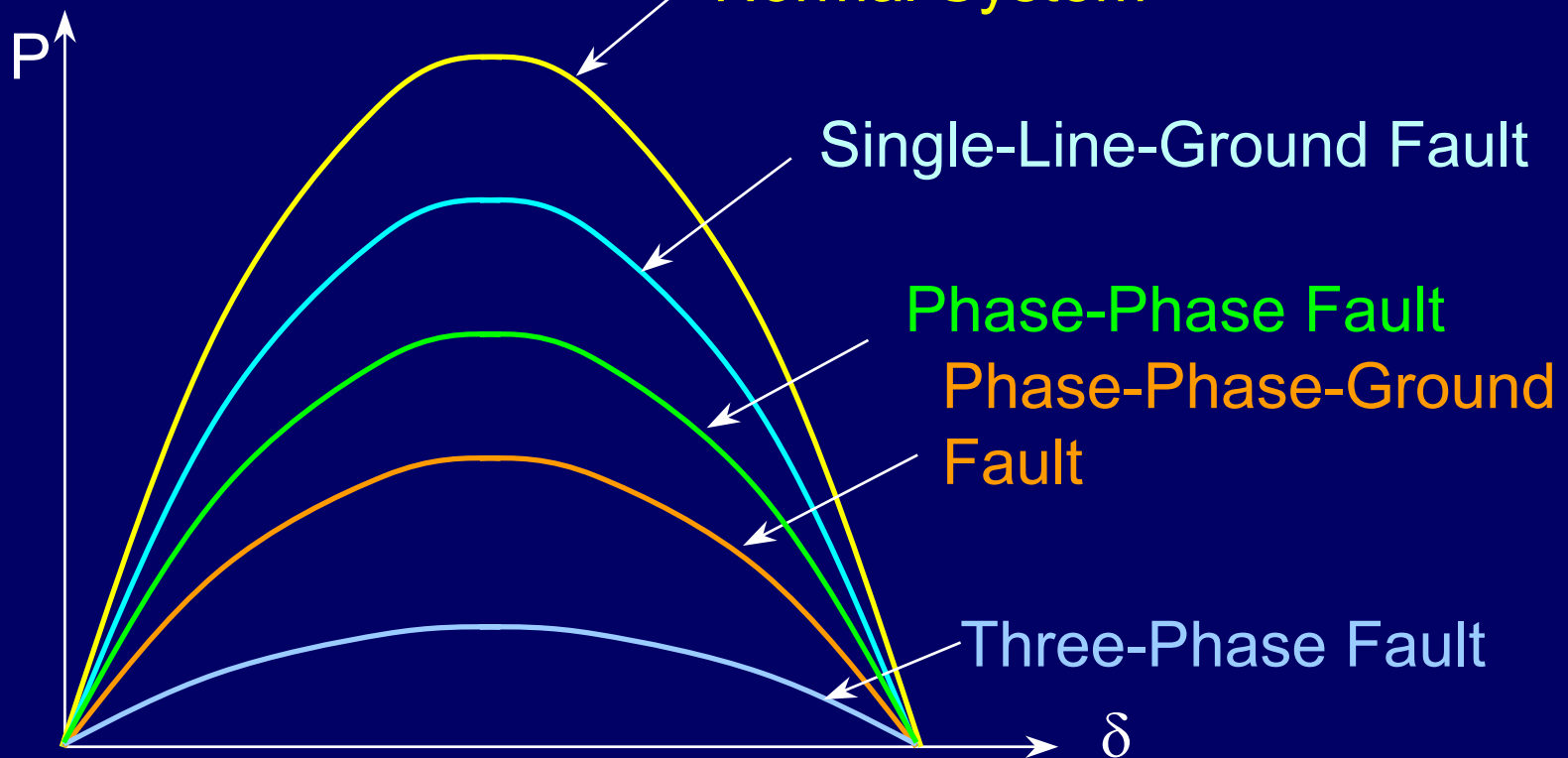
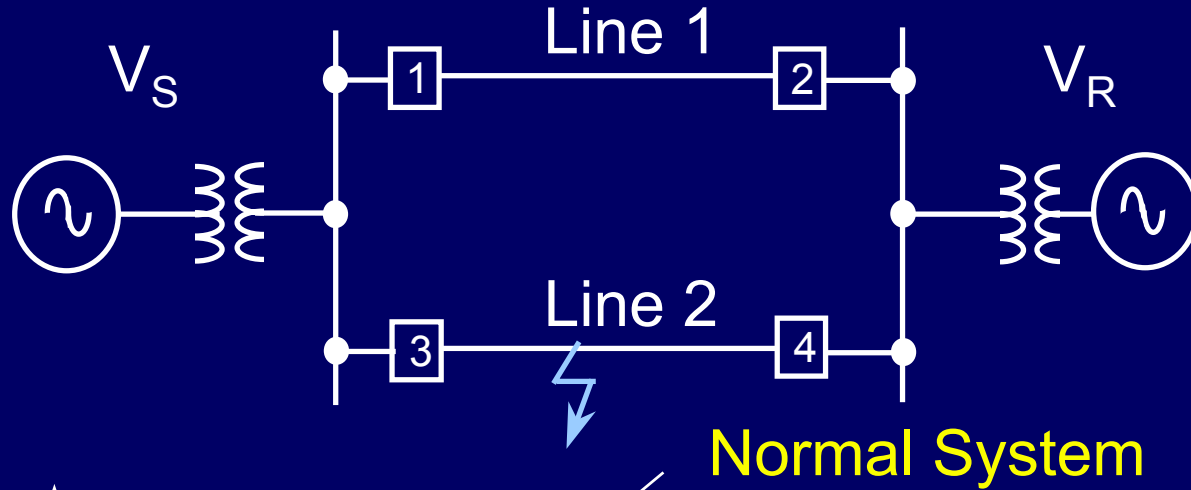

Transient Stability Concepts

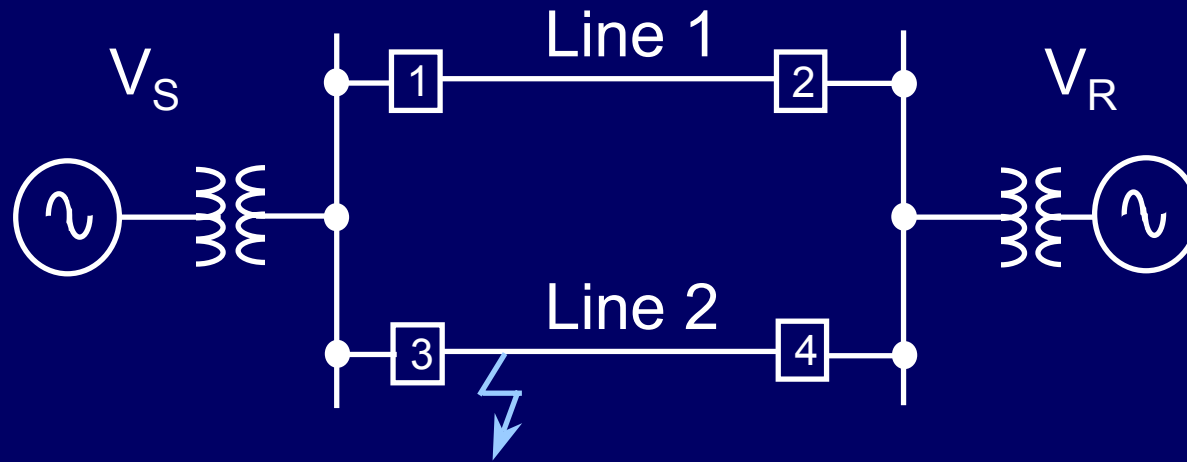

- Prefault state (Both lines in service)
- Fault state
- Fault state with breaker 3 open
- Post-fault state (Line 2 out)

Equal-Area Criterion

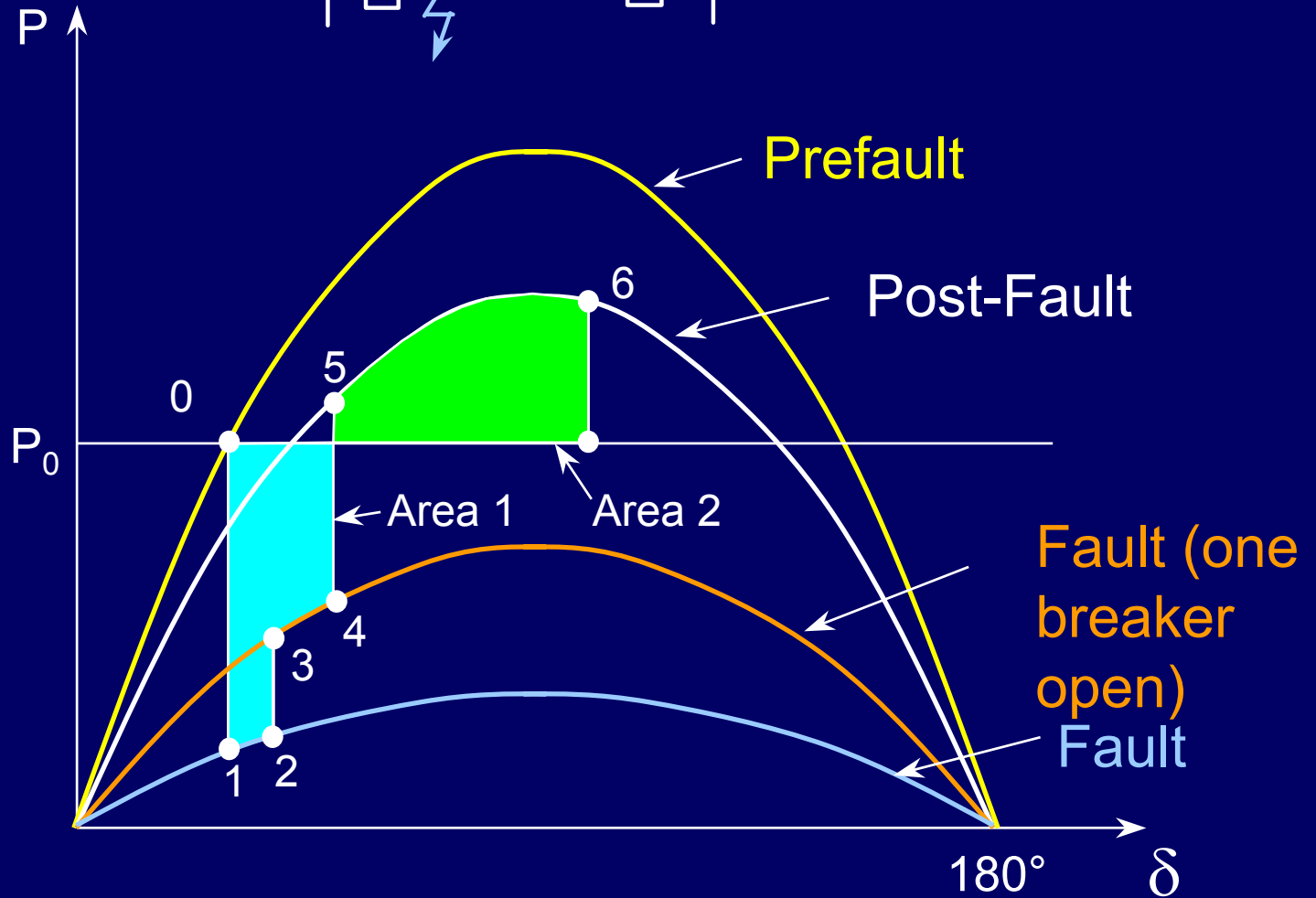
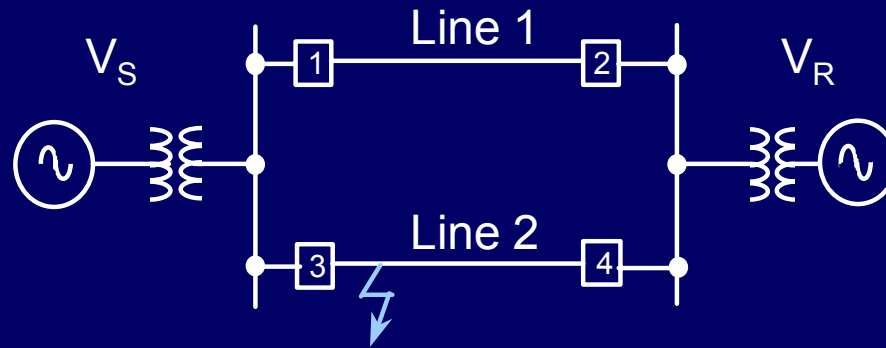

Effect of Fault Clearing Time Unstable System

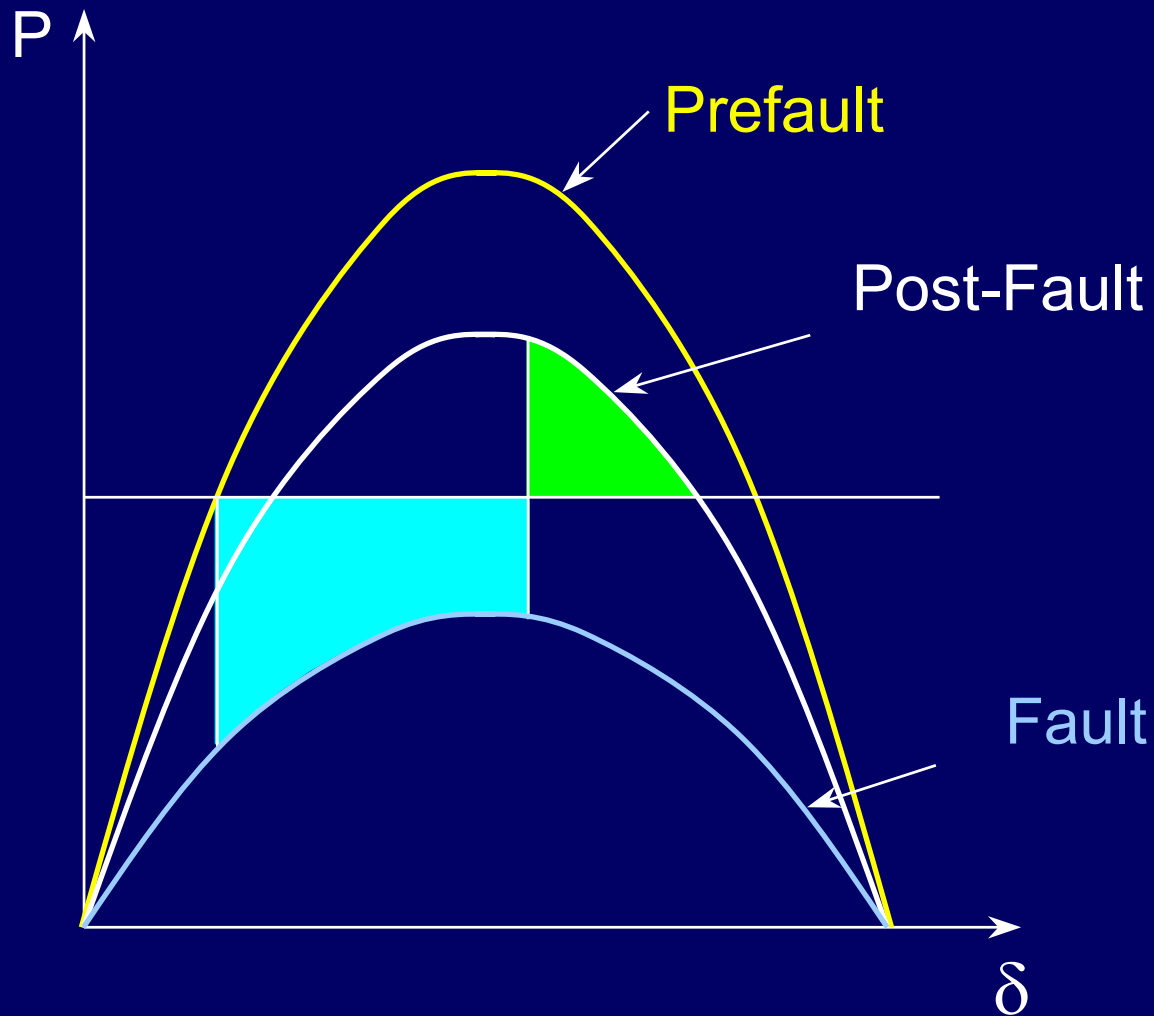

Stable and Unstable Power Swings

Rotor Angle

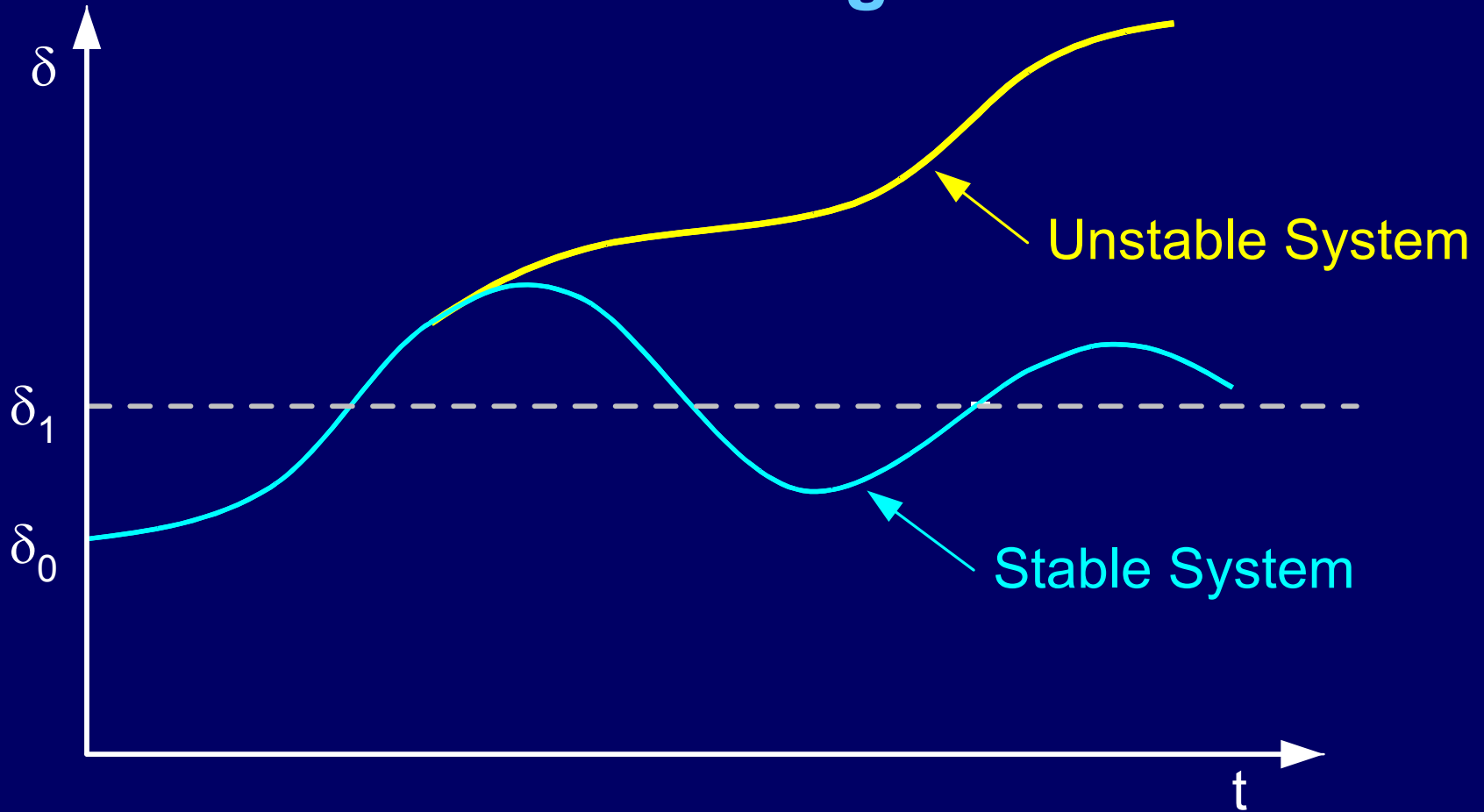

Angular Instability

Distinguishing Features

- Large voltage variations
- Large power oscillations
- Loss of synchronism
- Zero voltage at the electrical center
- Frequency excursions

Angular Instability

Large Voltage Variations

Voltage Magnitude

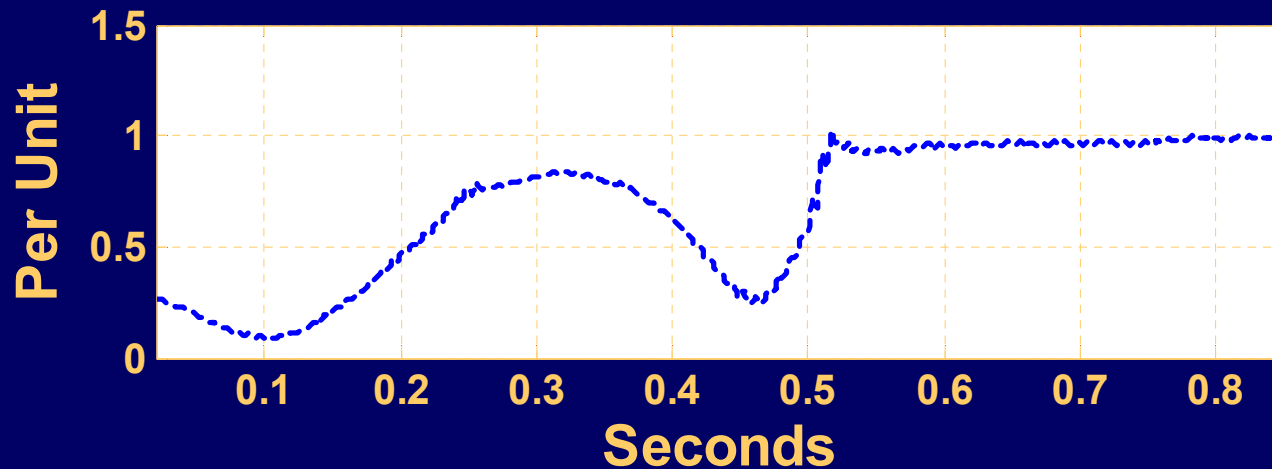
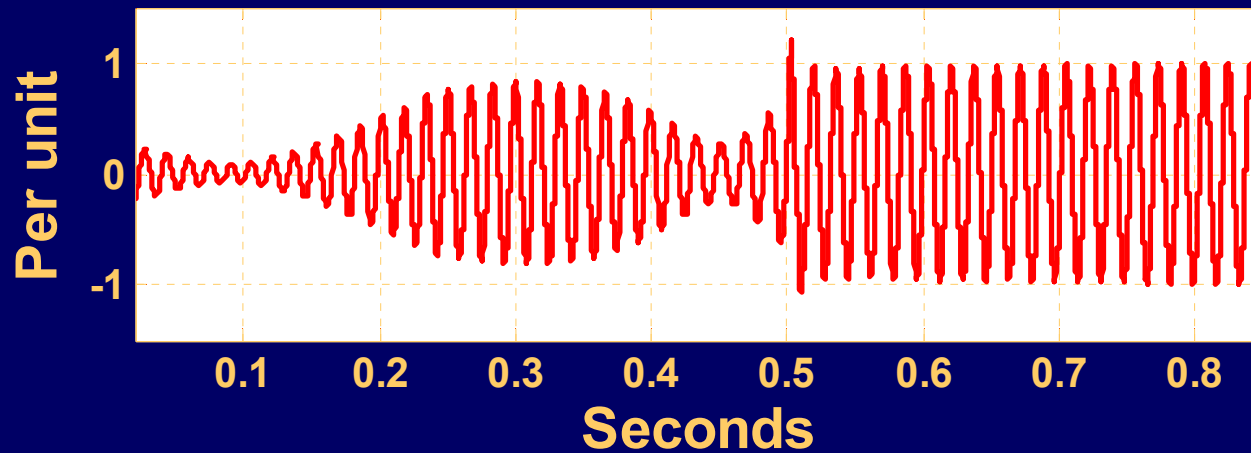

Angular Instability

Large Power Oscillations

Real and Reactive Power

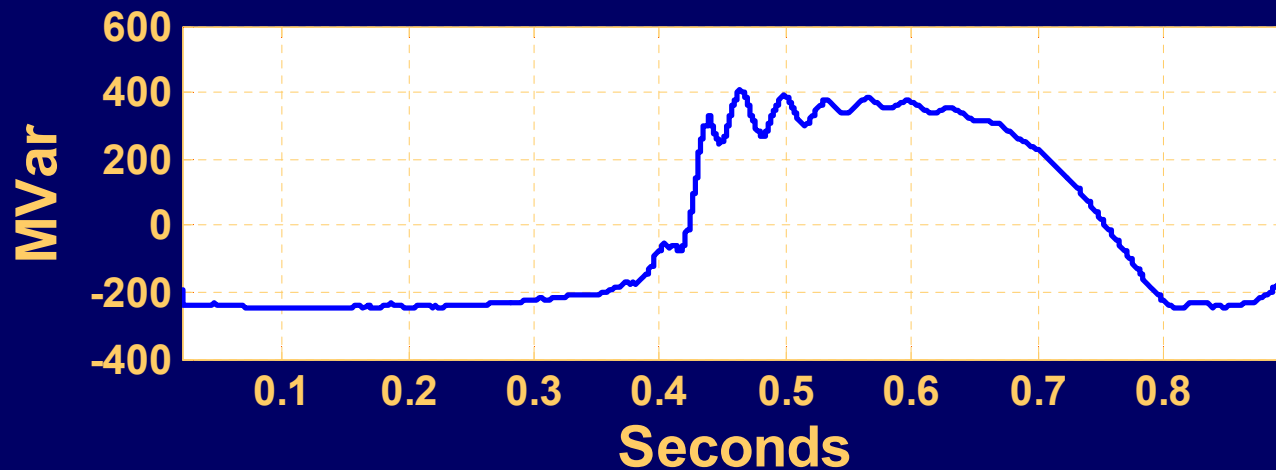
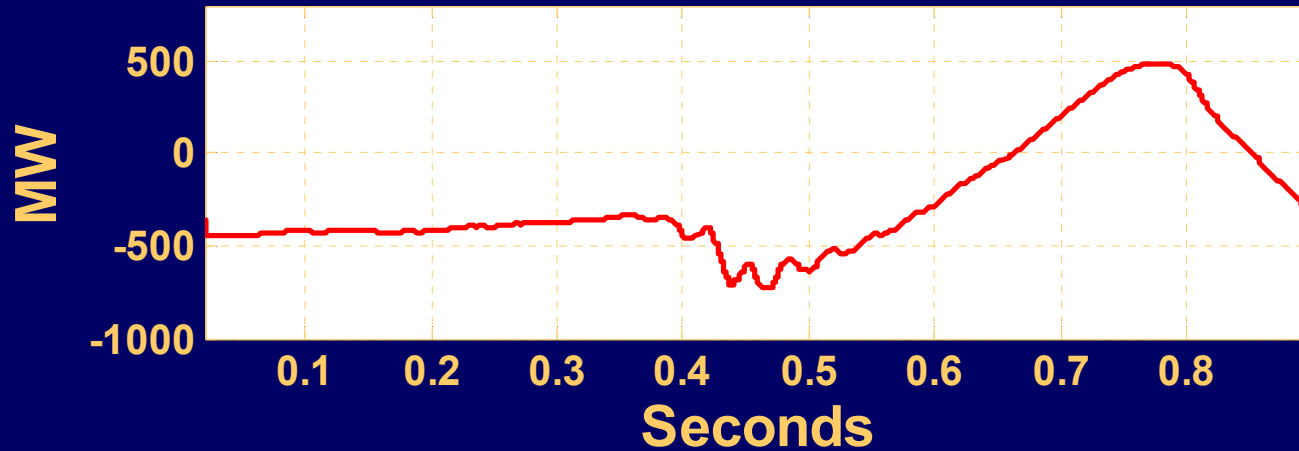

Angular Instability

V_1 and Angle of V_1 / I_1

Positive-Sequence Voltage Magnitude

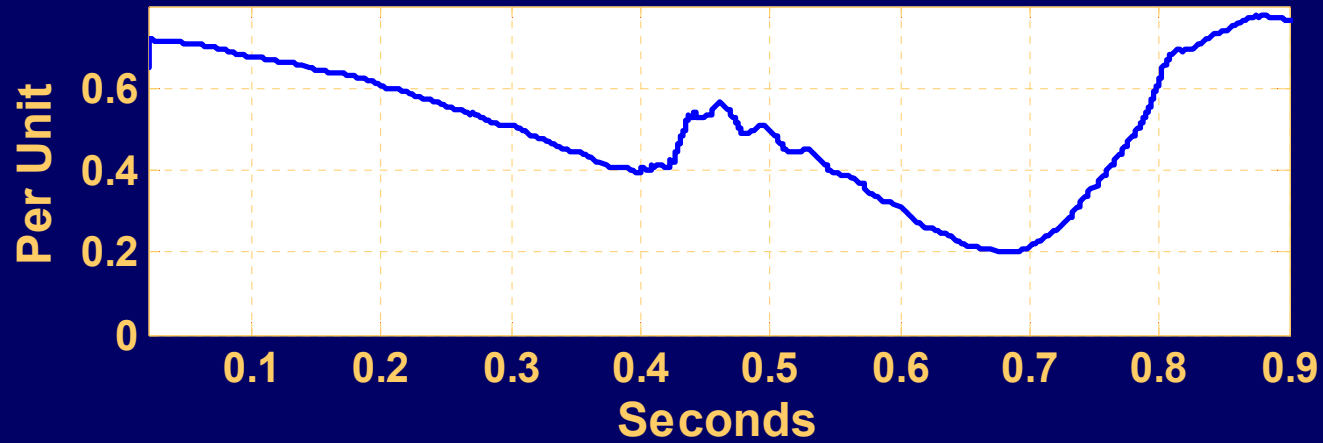

Angle of (V_1 / I_1)

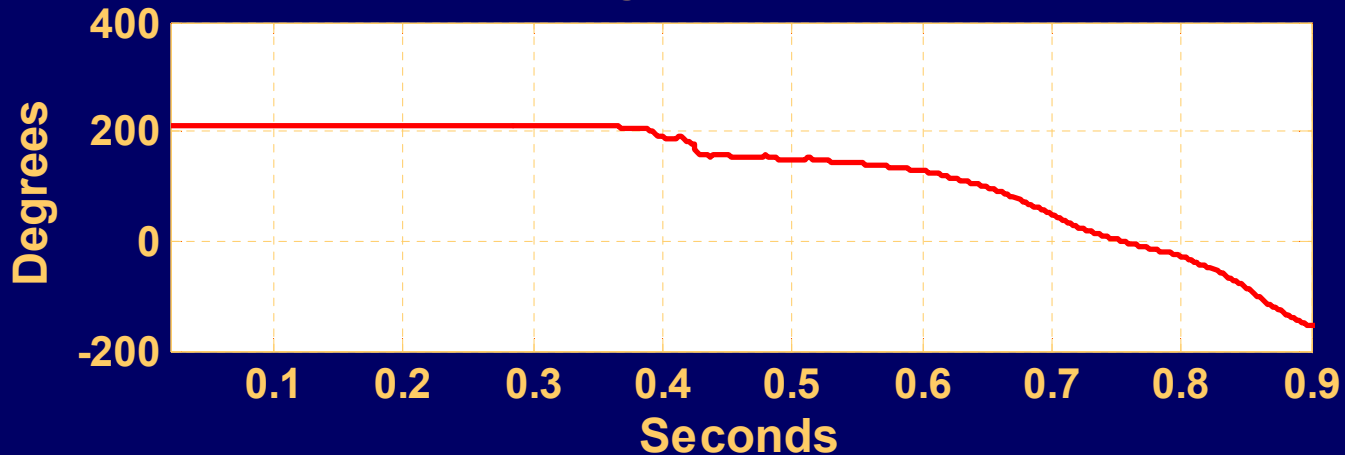

Relay Elements Prone to Operate During Power Swings

Stable and Unstable Power Swings

Impedance Trajectories

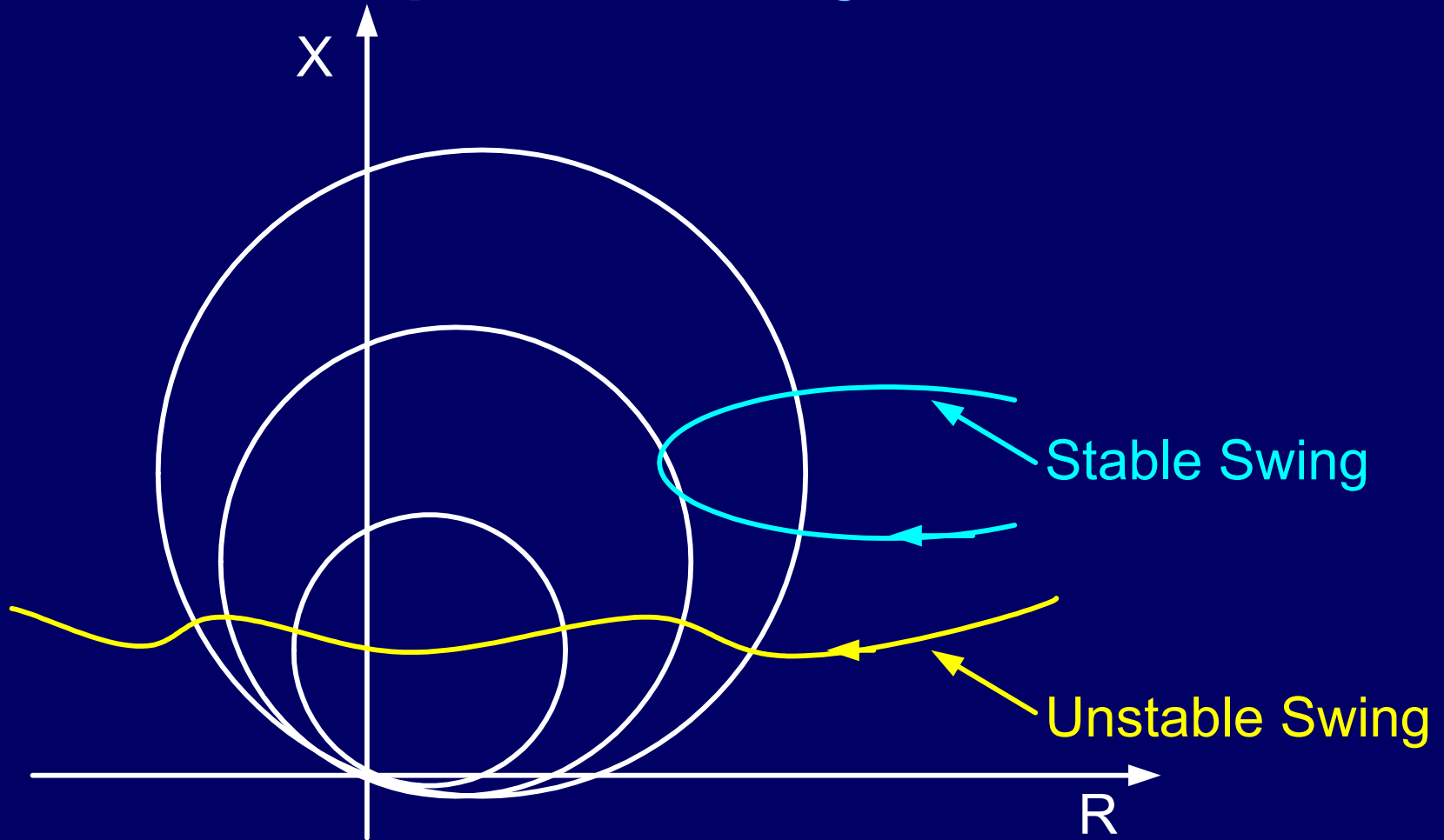

Relay Elements Prone to Operate During Power Swings

- Instantaneous phase overcurrent
 - ◆ Directional and non-directional
- Undervoltage
 - ◆ Short time or instantaneous
- Zone 1 distance
- Zone 2 distance used in POTT scheme

Line Relays Prone to Operate During Angular Instability

- Zone 1 distance or overreaching distance elements applied in DCB or POTT schemes
- Potential reasons are:
 - ◆ Lack of PSB function or improper settings of the PSB function
 - ◆ Lack of frequency tracking and long memory polarizing voltage
 - ◆ Phasor measurement errors due to large excursions of system frequency during islanding

Relay Systems Unresponsive to Power Swings

- Phase comparison
- Line current differential
- Pilot-wire

Impedances Measured by Distance Relays

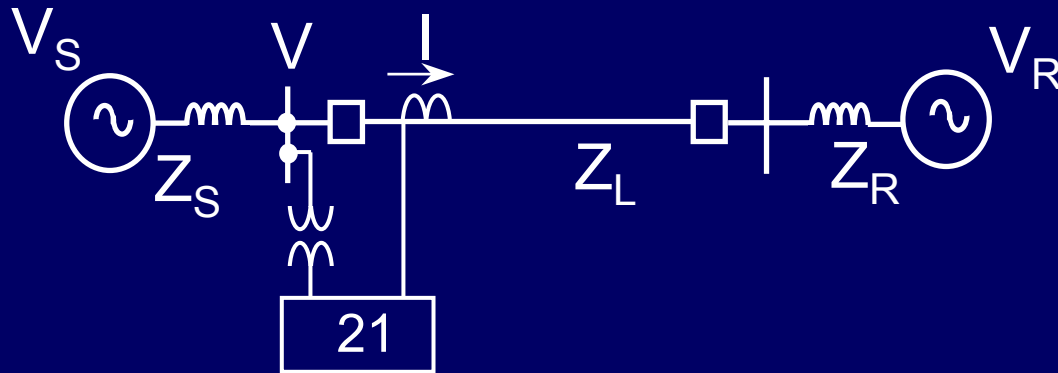

$$\vec{Z} = \vec{V} / \vec{I} = \frac{\vec{V}_S}{\vec{V}_S - \vec{V}_R} \left(\vec{Z}_S + \vec{Z}_L + \vec{Z}_R \right) - \vec{Z}_S$$

Impedance Locus for $k = E_S / E_R = 1.0$

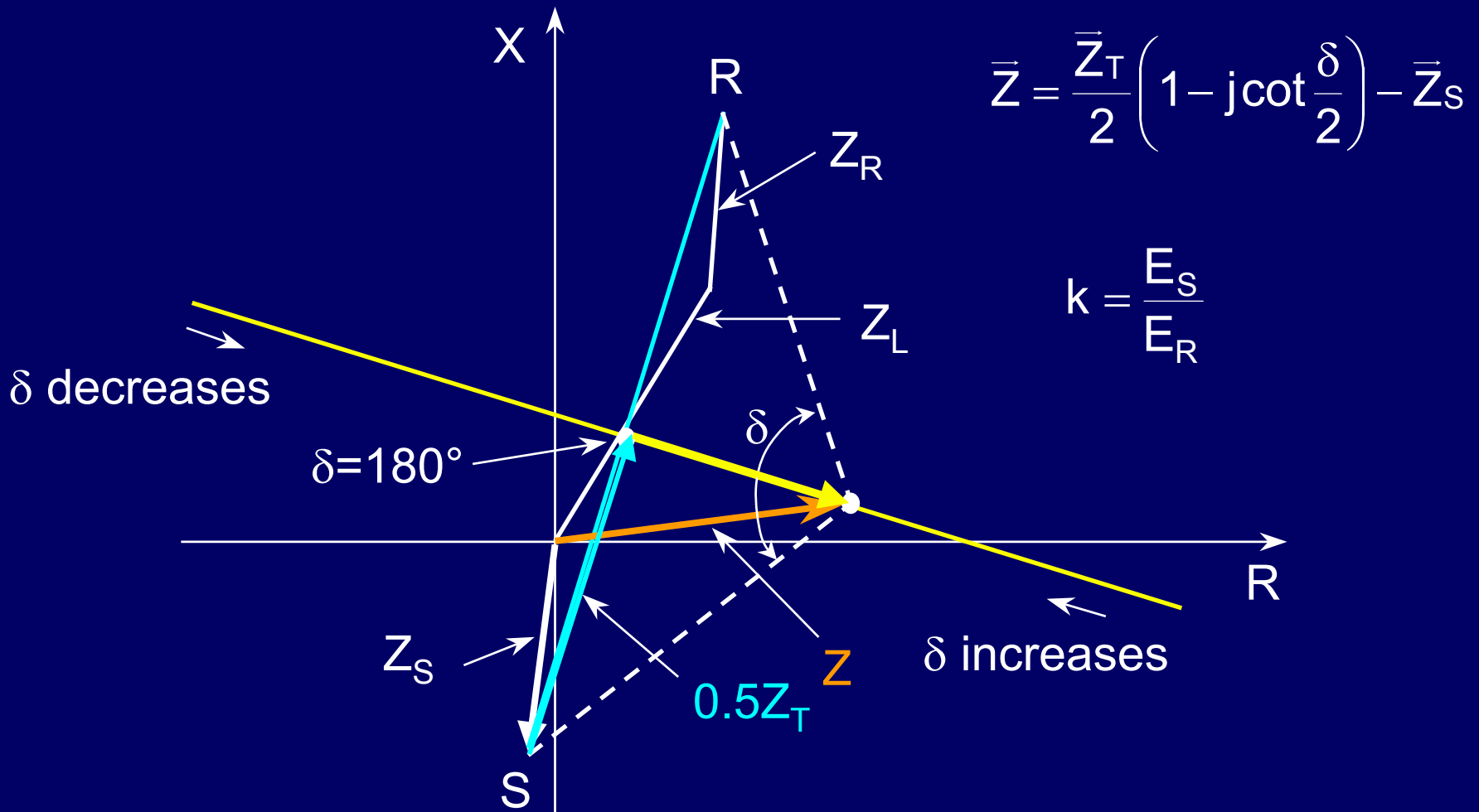

Two-Machine System Impedance Loci

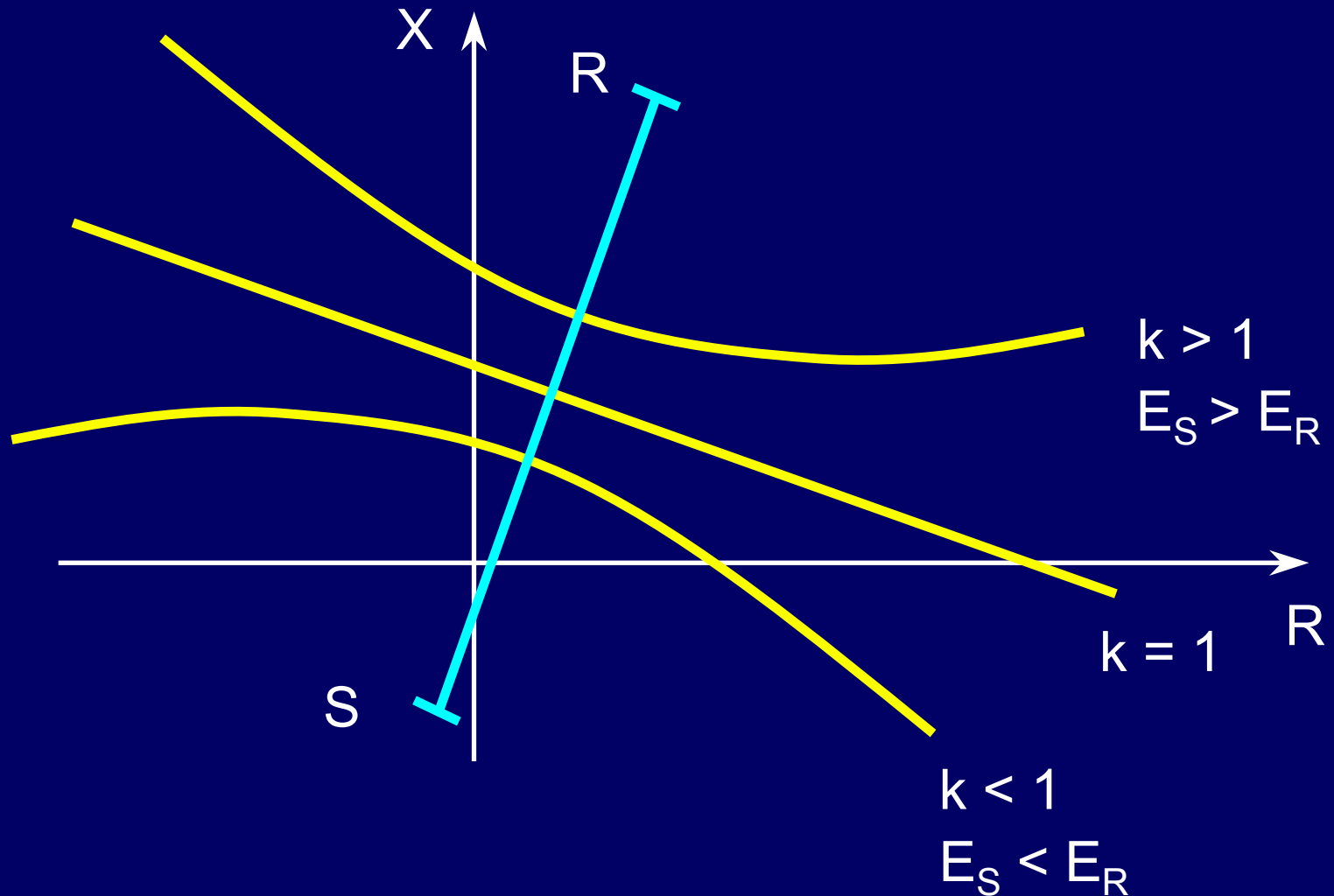

Power-Swing Protection Relay Functions

Clarify the Terminology

- Unstable power swing
- Out of step (OOS)
- Out-of-step blocking (OSB)
- Power-swing blocking (PSB)
- Out-of-step tripping (OST)
- Pole-slip tripping

Power-Swing Protection Relay Functions

- Power-swing blocking (PSB)
 - ◆ Detects both stable and unstable power swings
 - ◆ Prevents operation of protection elements
- Out-of-step tripping (OST)
 - ◆ Detects unstable power swings or OOS
 - ◆ Separates system into islands with good generation / load balance

Conventional PSB Scheme

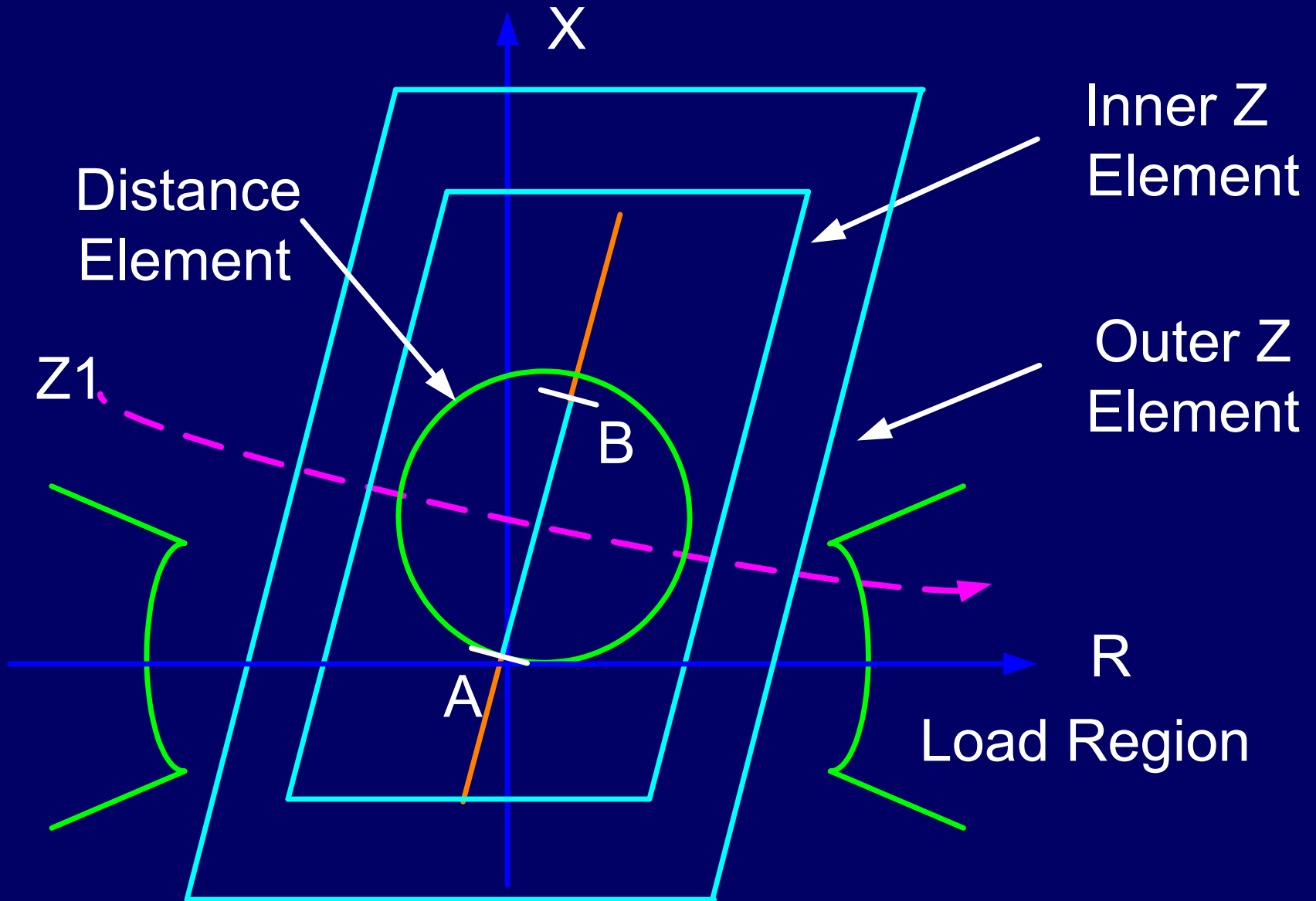

Conventional OST Scheme

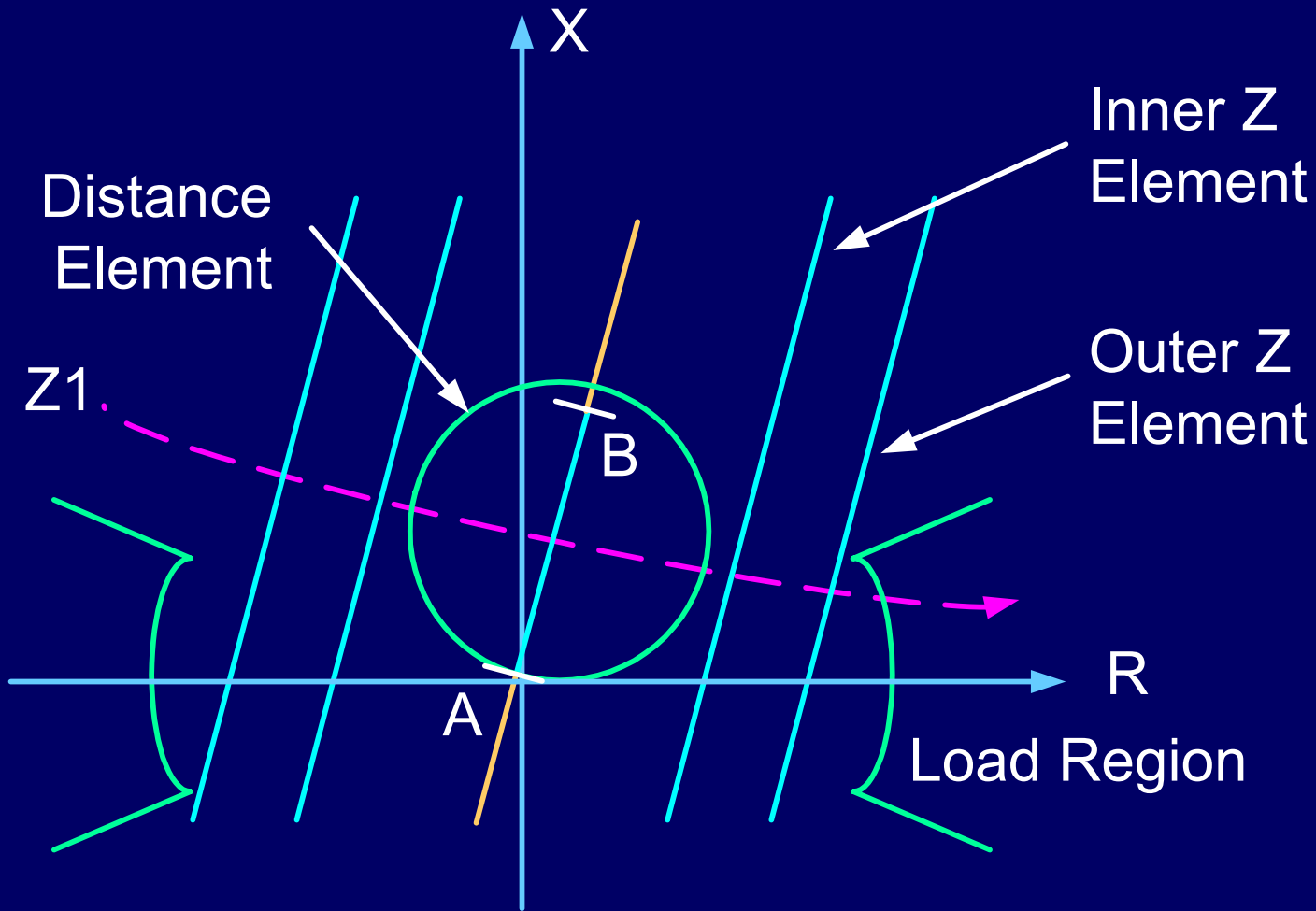

Disadvantages of Conventional PSB Scheme

- Needs detailed system information
- Requires extensive system stability studies
- It is difficult to set for long lines with heavy loads
- May fail after severe disturbances on marginally stable systems
- May fail during swings with high slip frequency

Short Line With Light Load

$$z_L \ll z_\Sigma$$

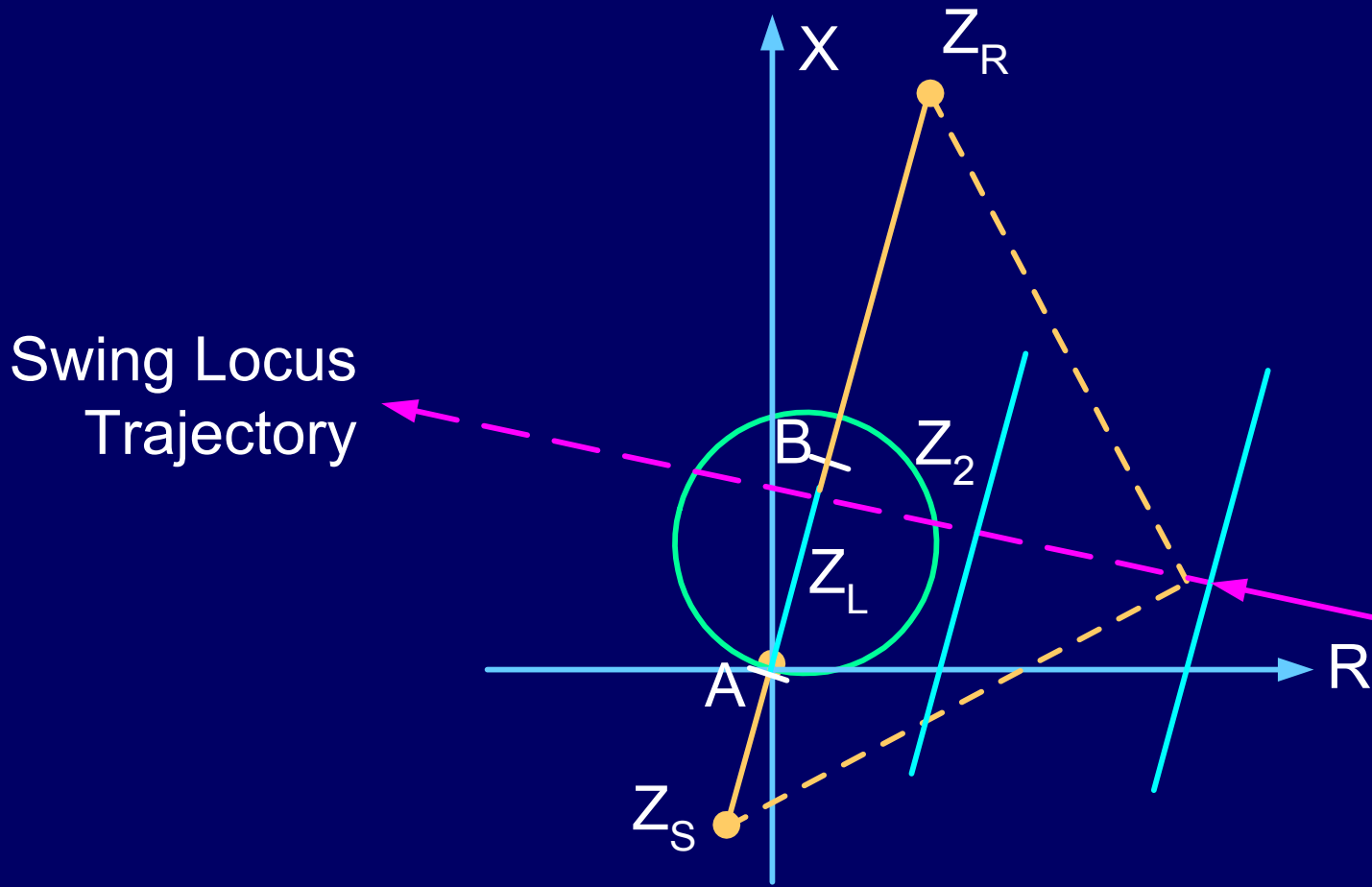

Unstable Swing After Severe Disturbance

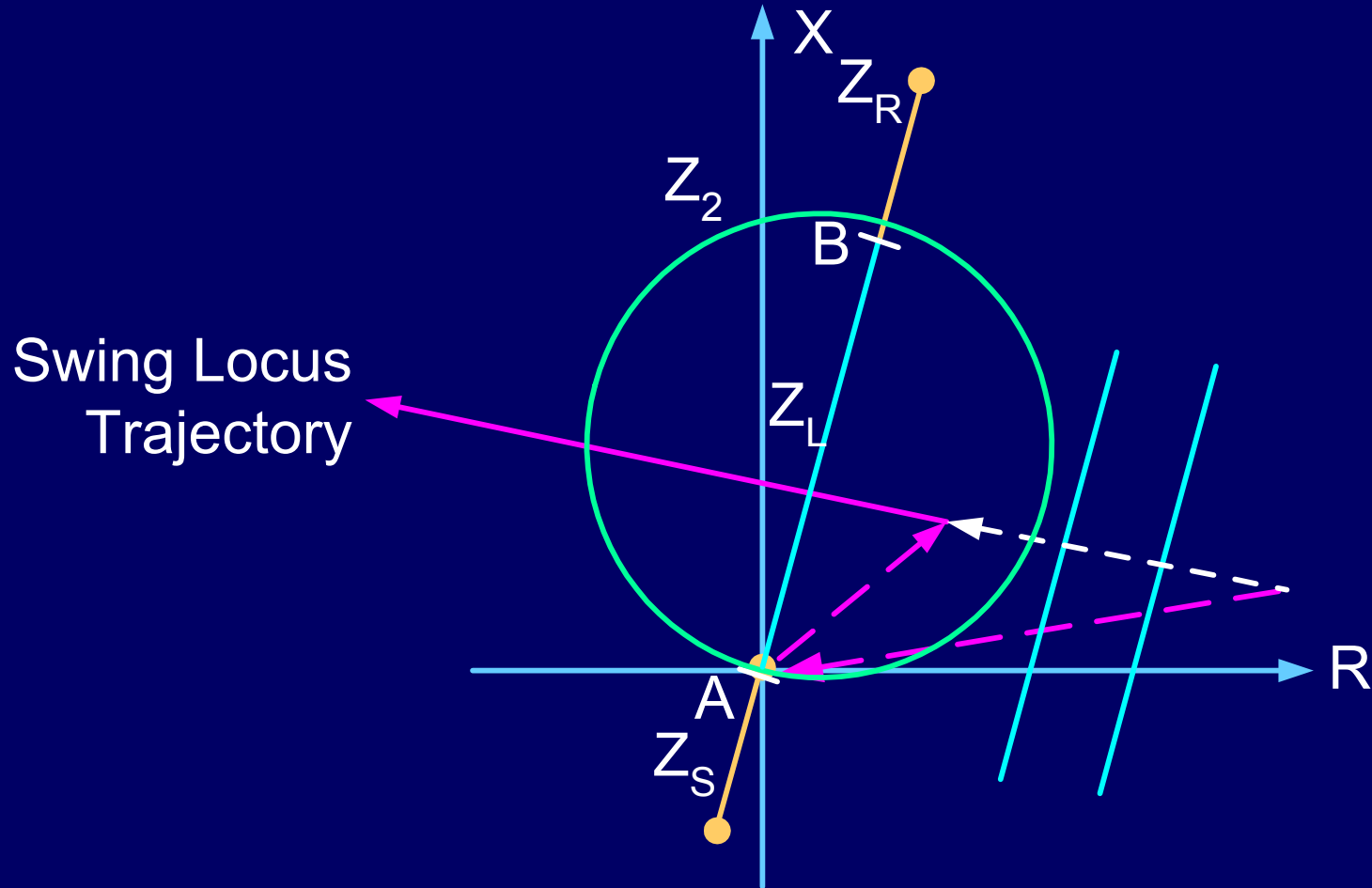

New Zero-Setting PSB Function

- Uses swing-center voltage (SCV)
- Has no user settings
- Does not need system parameters
- Does not require system stability studies
- Provides PSB during pole open
- Detects evolving faults during power swings

Swing-Center Voltage (SCV)

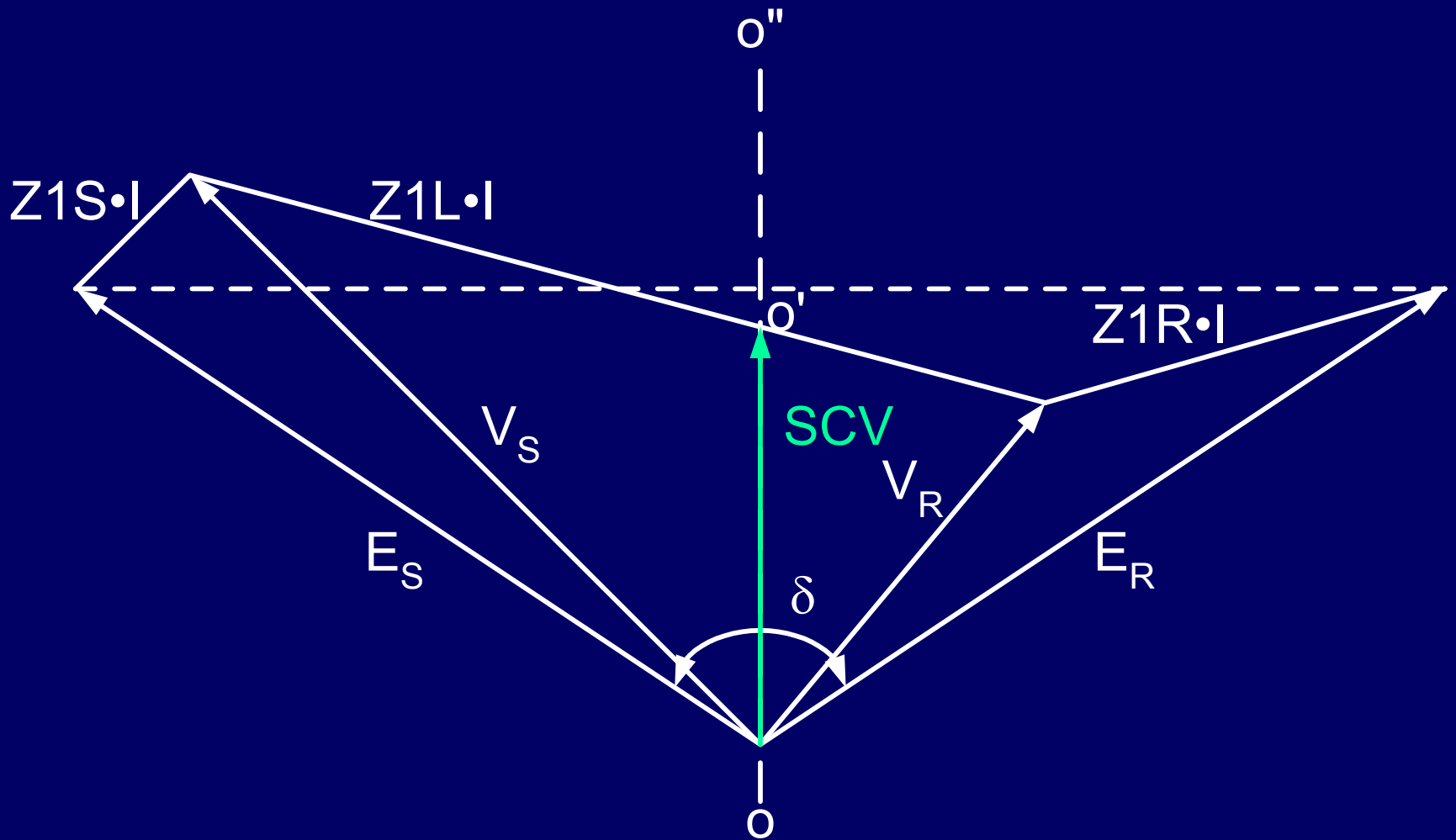

$$SCV(t) = \sqrt{2}E \sin\left(\omega t + \frac{\delta(t)}{2}\right) \cdot \cos\left(\frac{\delta(t)}{2}\right)$$

SCV During System OOS Condition

Swing-Center Voltage

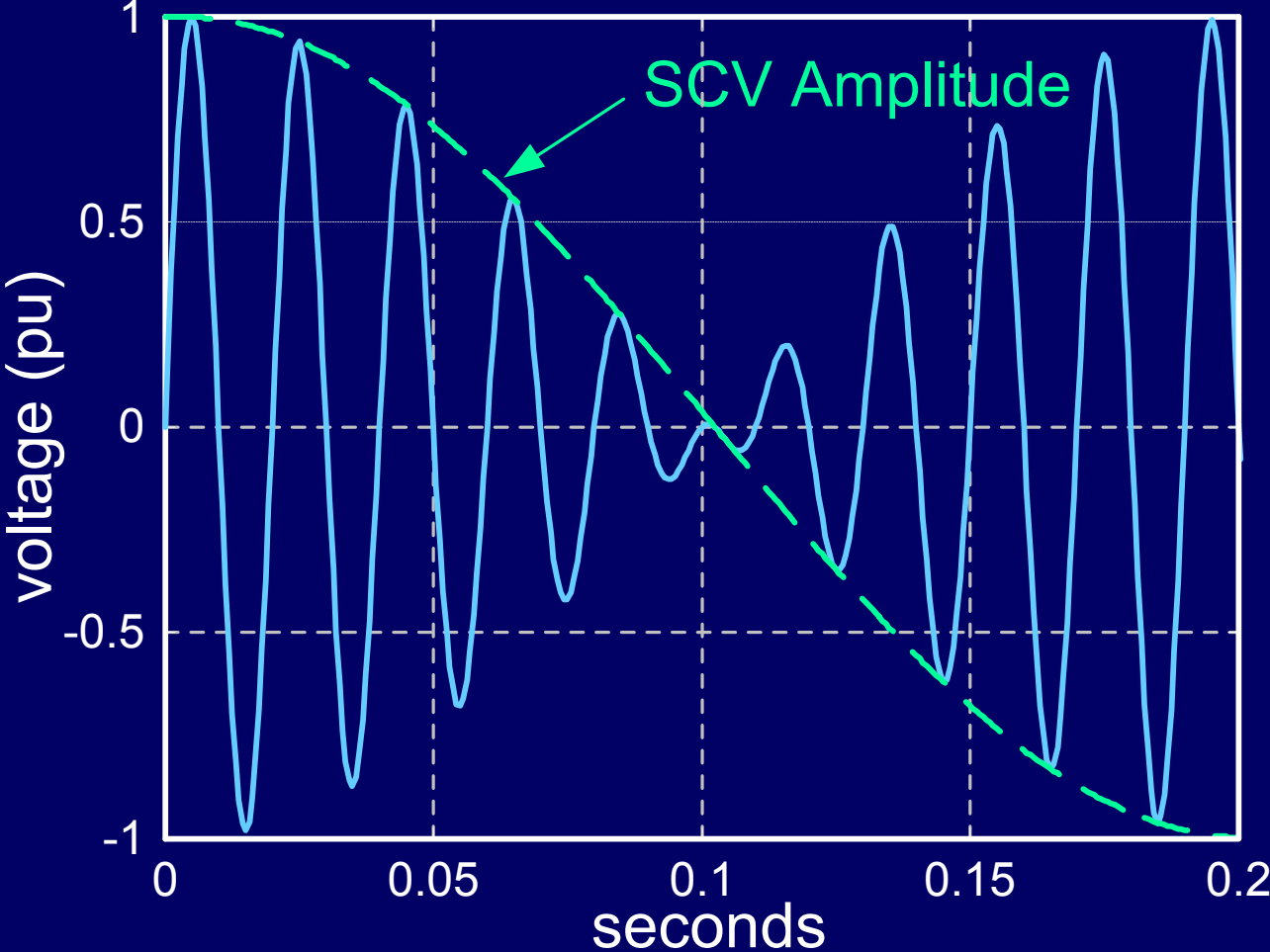

Local Estimate of SCV: $V \cos \varphi$

$$\text{SCV} \approx |V_S| \cdot \cos \varphi$$

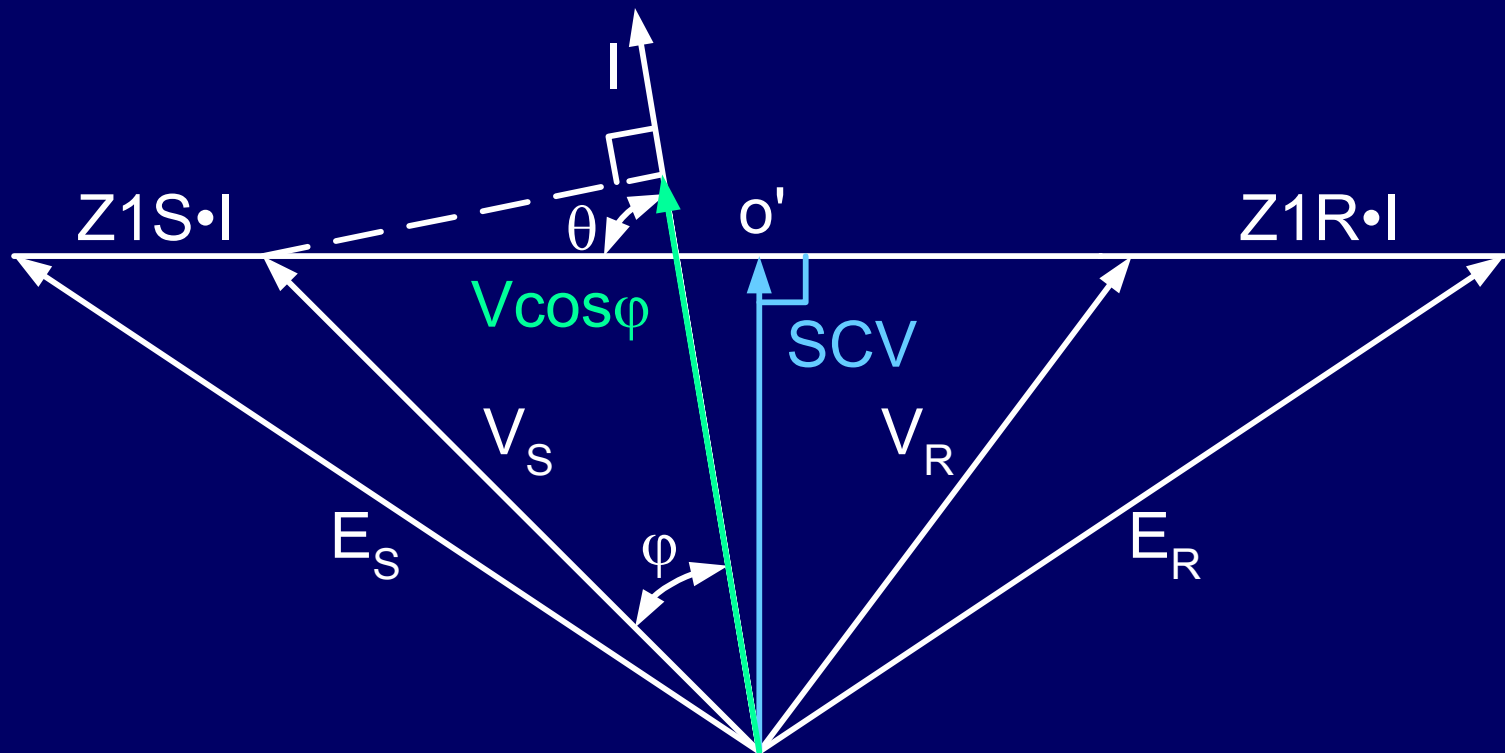

θ : System Impedance Angle

Local Estimate of SCV: $V \cos \varphi$

$$\text{SCV1} = E1 \cdot \cos\left(\frac{\delta}{2}\right)$$

$$\frac{d(\text{SCV1})}{dt} = -\frac{E1}{2} \sin\left(\frac{\delta}{2}\right) \frac{d\delta}{dt}$$

$V \cos \phi$ for 1-Rad/Sec OOS Condition

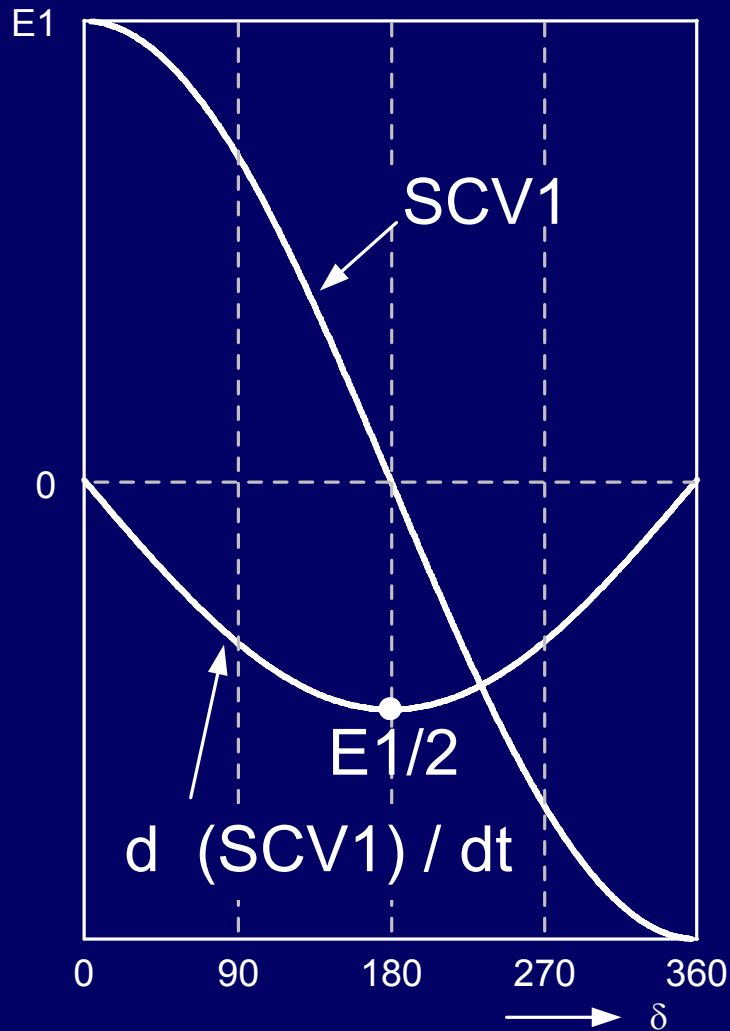

Benefits of SCV for PSB Application

- Independent of system source and line impedance
- Bounded:
 - ◆ Lower limit: zero
 - ◆ Upper limit: close to one per unit
- Relates directly to angle difference of two sources, δ

Transmission Line Relay Performance During Out-of-Step Conditions

500 kV System

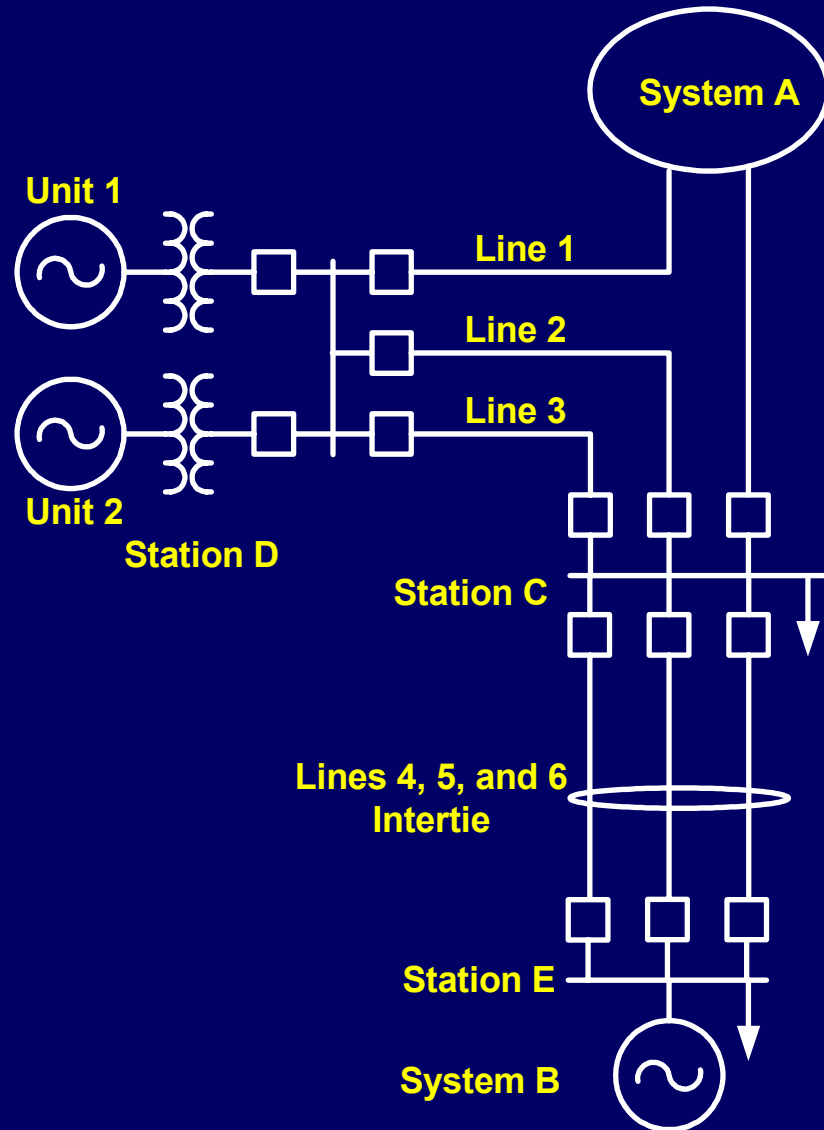

Angular Instability

Z_1 Trajectory – Line 2 at Station C

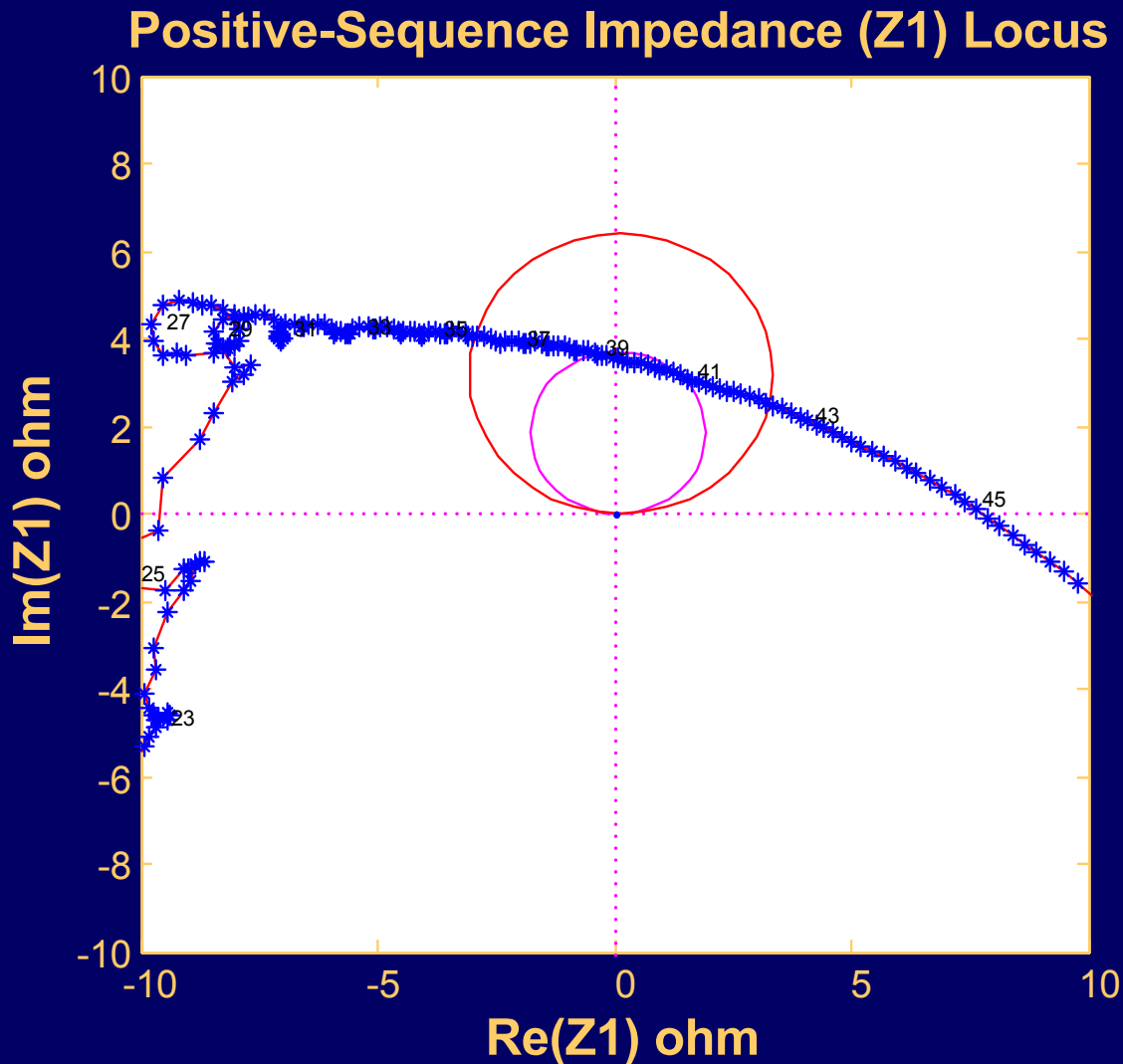

EHV System – Northern California

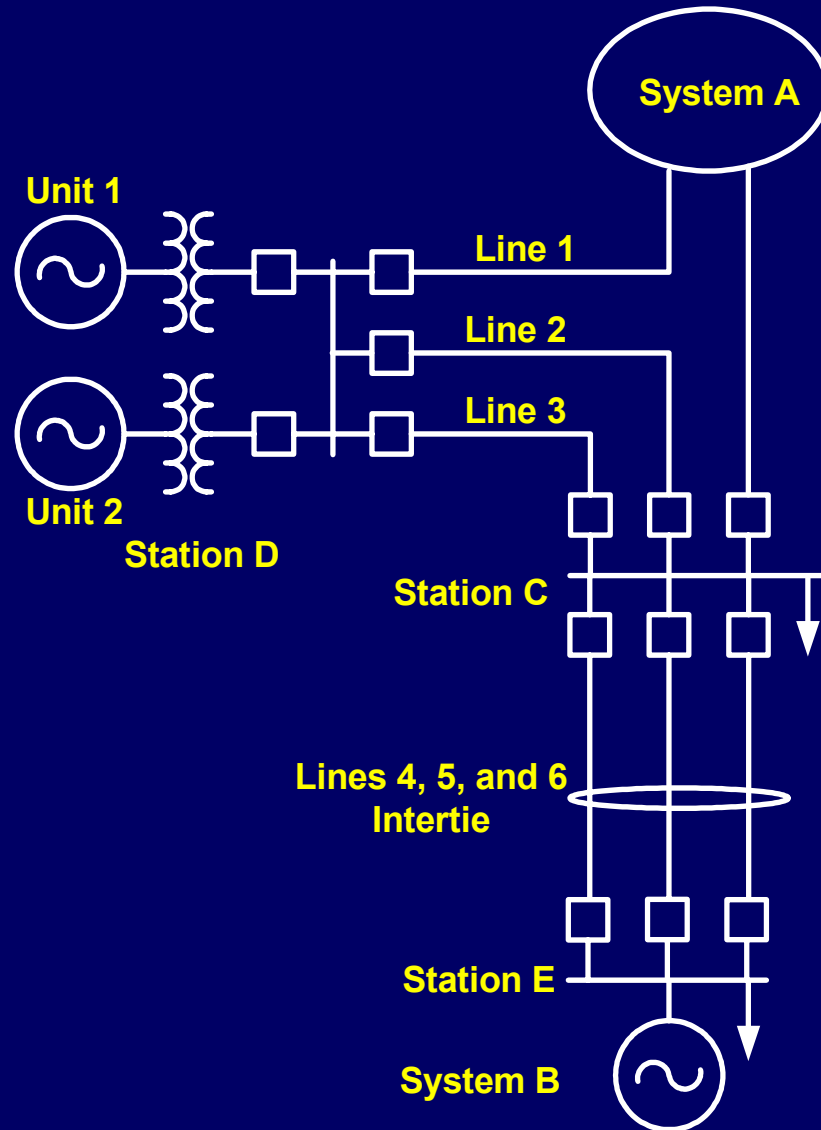

Zone 1 Operation During OOS

PSB Function not Enabled

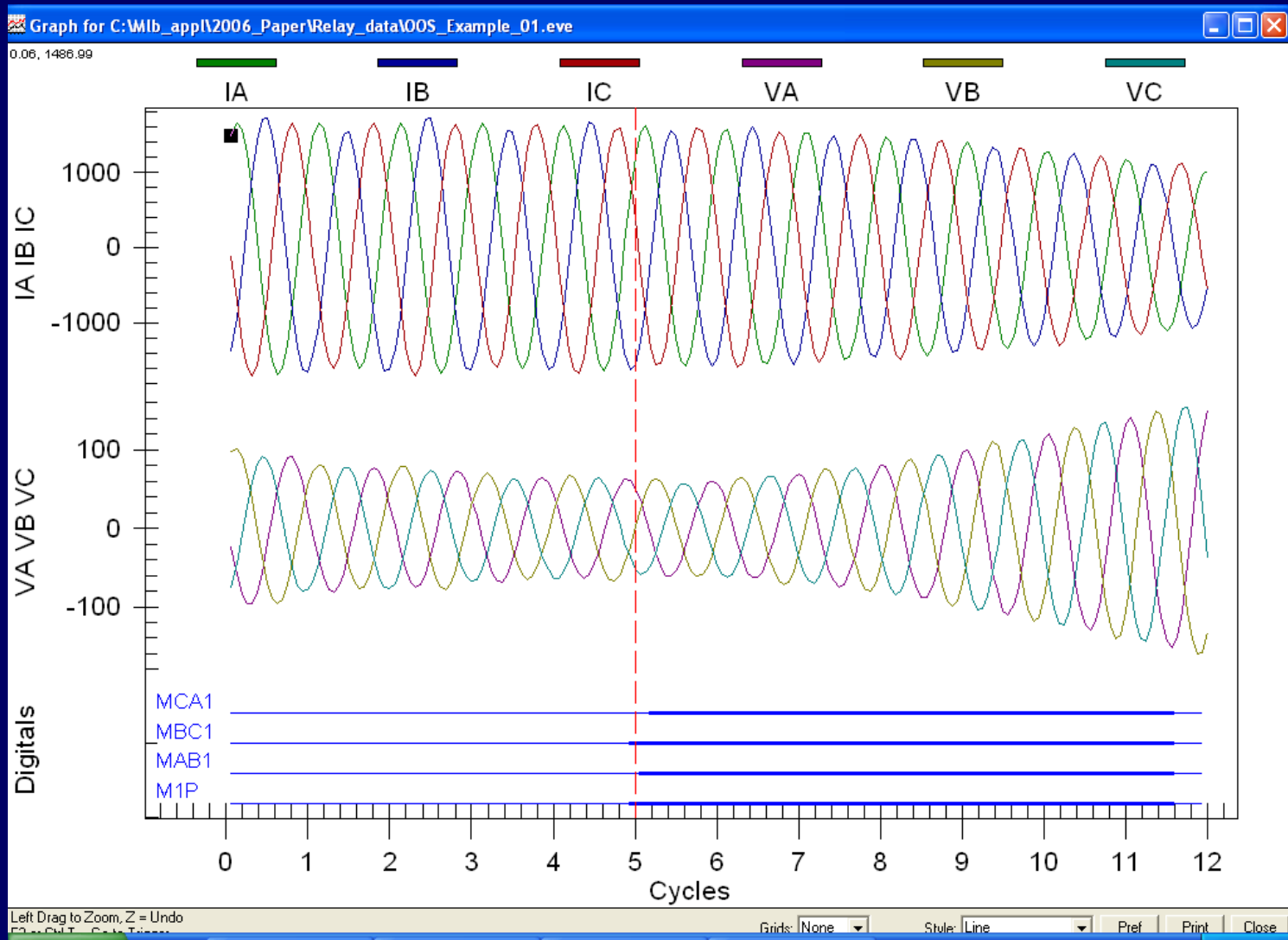

Zone 1 Distance Is Blocked First Slip Cycle

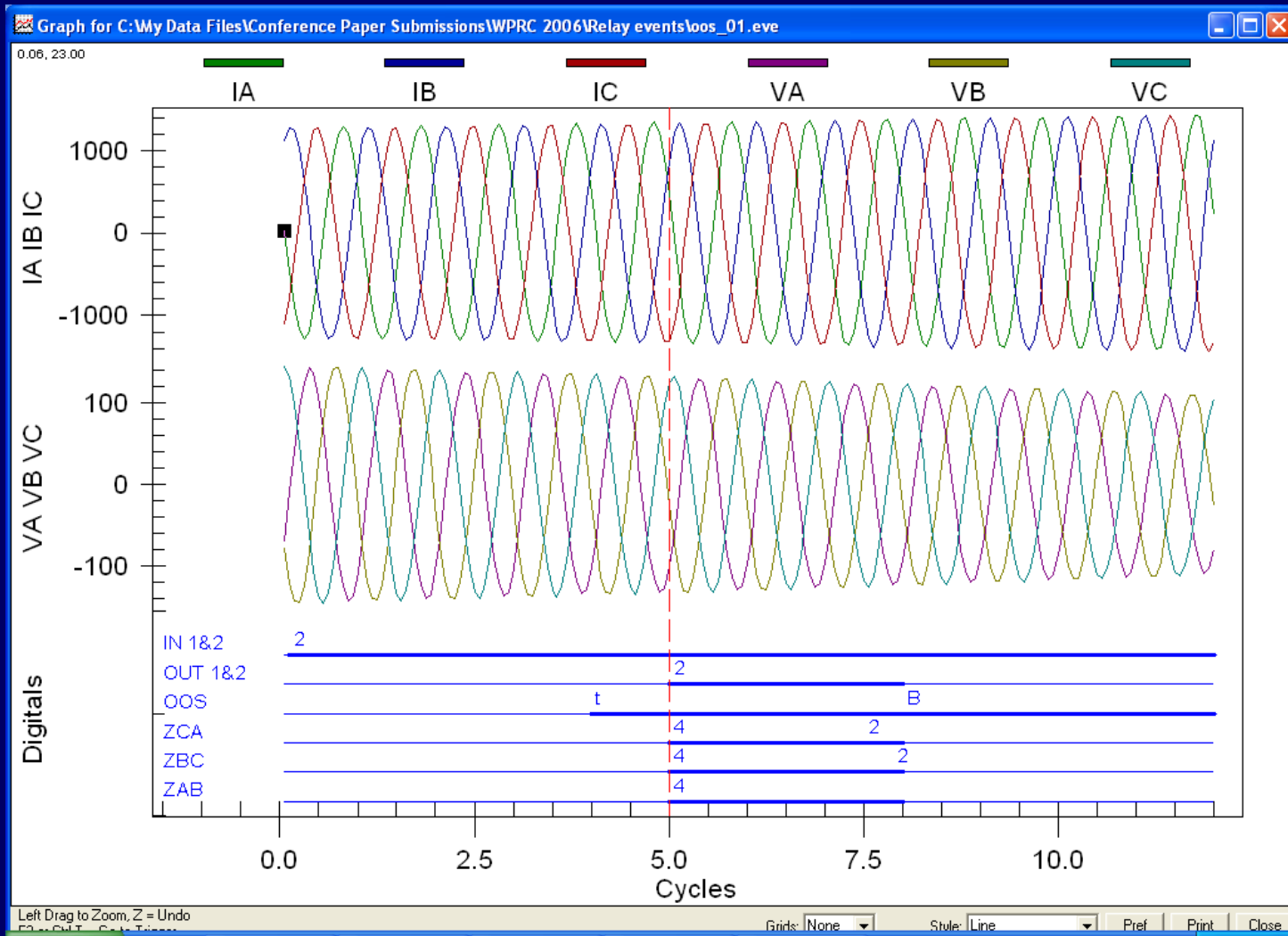

Zone 1 Distance Operates Second Slip Cycle

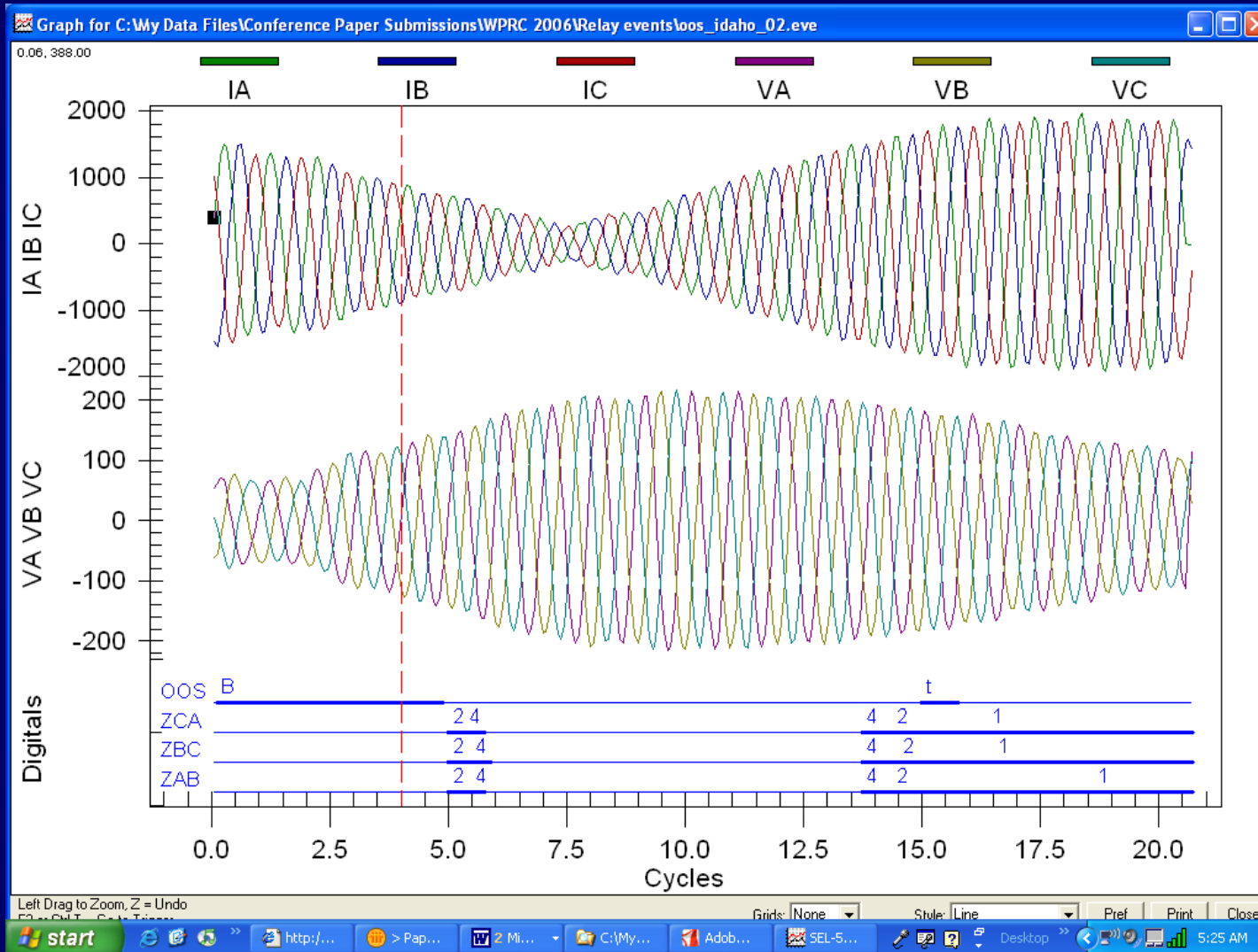

Zone 1 Distance Operates

Second Slip Cycle

- Fast slip frequency change
- Setting fine-tuning could have prevented operation of Zone 1
 - ◆ Concentric zone settings
 - ◆ Separation between concentric zones
 - ◆ PSB timer
- All of these settings are difficult to make
 - ◆ Long heavy loaded lines
 - ◆ Require large number of stability studies

Generator Relay Performance During Disturbances

Units 1 and 2 Operations

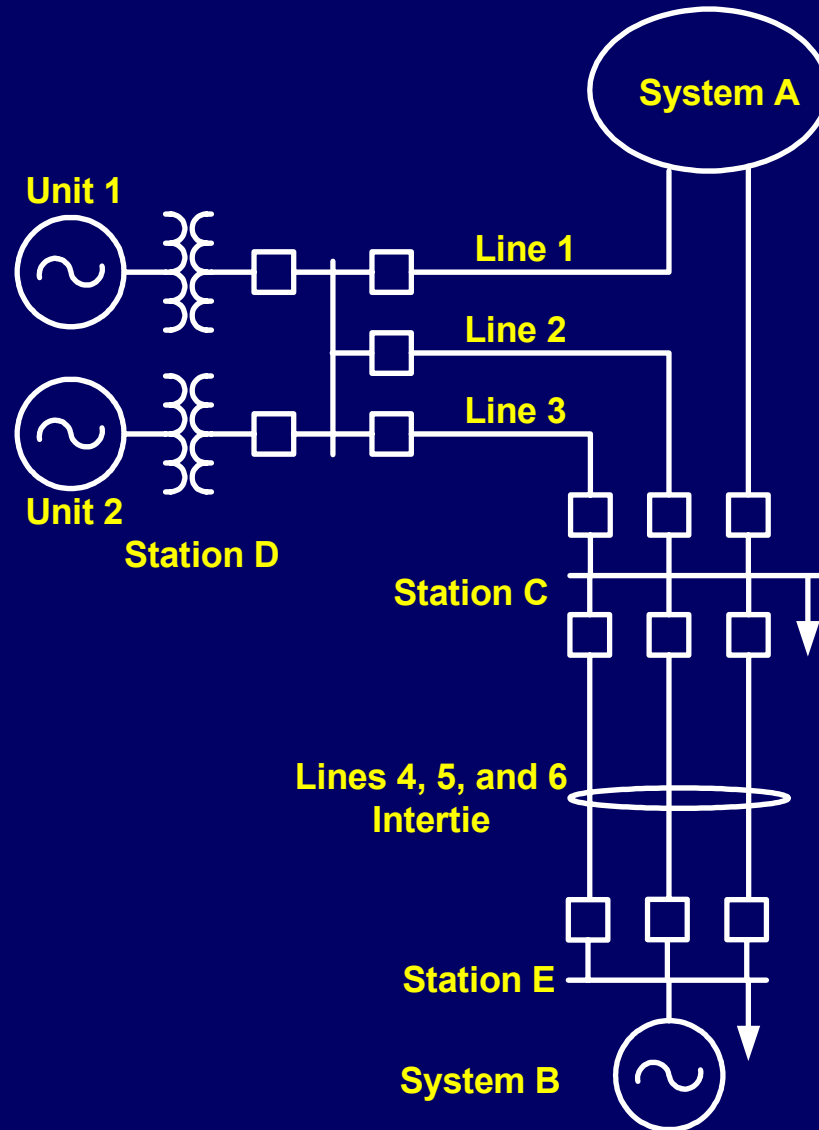

One Unit Trips by Undervoltage

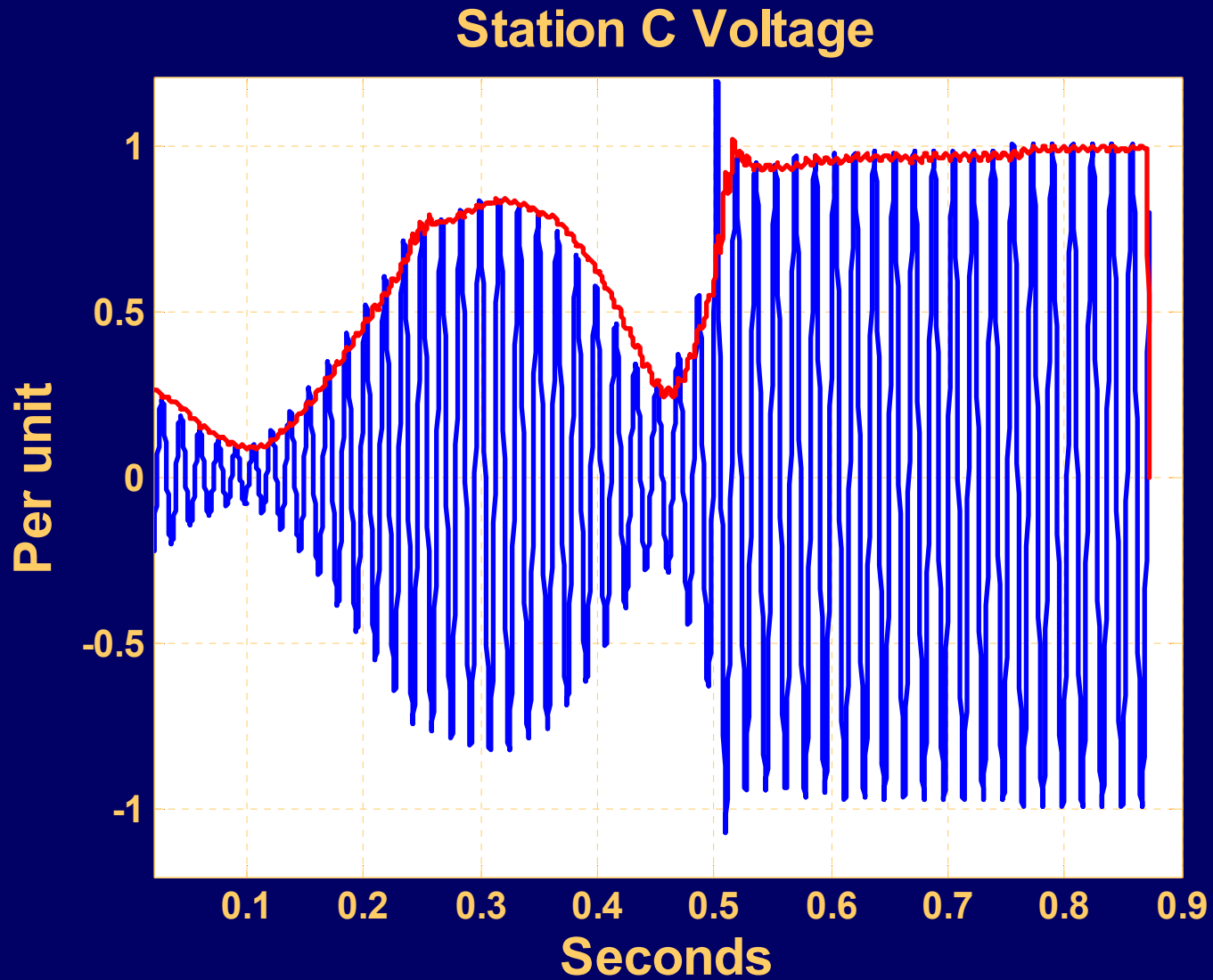

Unit 1: Three-Phase P and Q During OOS

Real Power

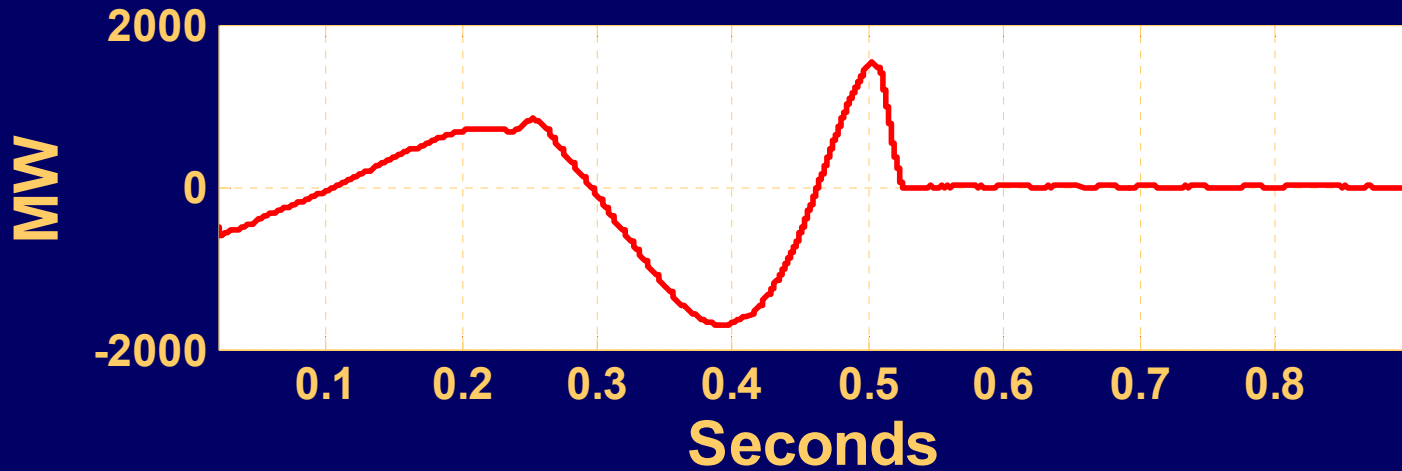

Reactive Power

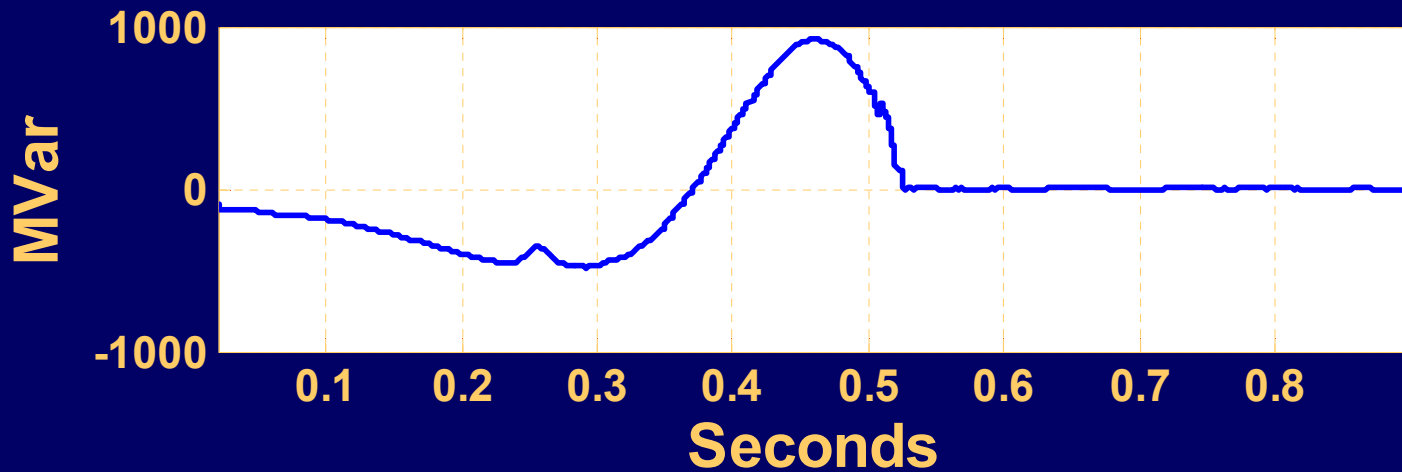

Units 1 and 2 Trip

Inst. Dir. Phase OC Relay

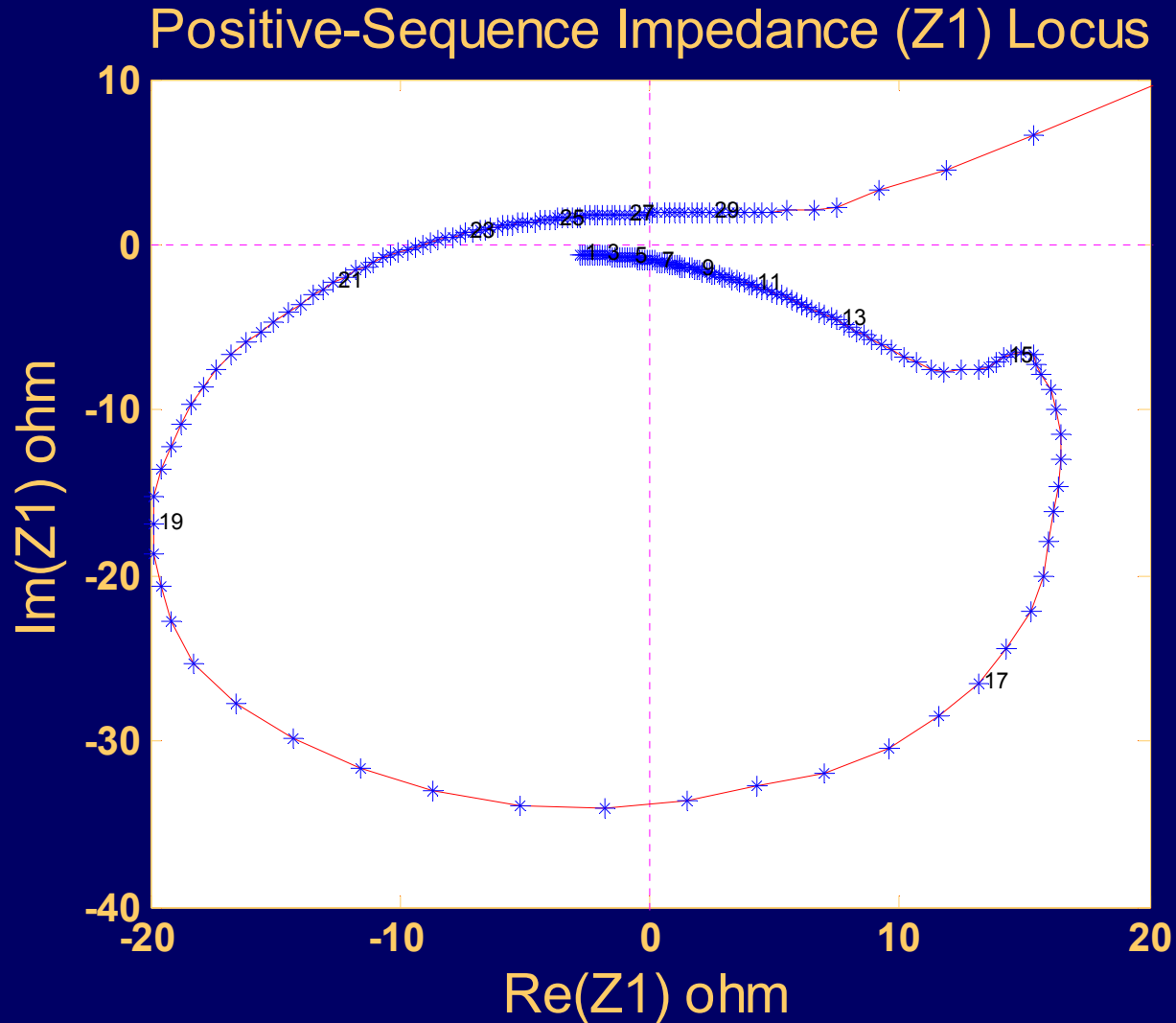

**Protection System
and Other System Improvements
to Preserve System Stability**

Proper System and Protection Design

Preserve System Stability

- Prevent the occurrence of out-of-step conditions
 - ◆ Install sufficient transmission capacity
 - ◆ Maintain adequate reactive reserves
 - ◆ Apply high-speed relaying systems and high-speed reclosing
 - ◆ Apply single-phase tripping and reclosing
 - ◆ Apply wide-area stability controls

Wide-Area Stability Controls or SIPS Preserve System Stability

- Wide-area stability controls
 - ◆ Generator dropping
 - ◆ Direct load dropping
 - ◆ Fast valving
 - ◆ Insertion of breaking resistors
 - ◆ Series and shunt capacitor insertion
 - ◆ Use FACTS devices

Protection System and Other Improvements

- Improvements in transient stability
 - ◆ High speed fault clearing
 - ◆ Single phase tripping and reclosing
 - ◆ Apply local breaker failure protection on all EHV and critical HV substations
 - ◆ Special protection systems
- Controlled system separation
- UVLS and UFLS

Protection System Improvements

- Apply dual pilot protection relay systems on all EHV and critical HV systems with
 - ◆ PSB capability, or with systems that are immune to stable or unstable power swings
- Replace secondary non-pilot line relay systems in non-critical HV lines with:
 - ◆ A relay system that has similar functionality with the main pilot protection system
 - ◆ Consider switching the communications channel to the secondary relay system when the Main 1 is out of service

Conclusions

- Utilities must take every action economically justifiable to preserve system stability
- Out-of-step tripping should be applied and operate only as a last resort to preserve system stability
- OST and PSB should be applied based on an inter-regional controlled system separation philosophy

Conclusions

- OOS tripping must separate the system at predetermined locations to minimize the effect of the disturbance
- OOS blocking compliments OOS tripping by blocking relay elements prone to operate and ensures a controlled system separation
- Controlled separation schemes provide a safety net to lessen the impacts of major disturbances

References

Out-Of-Step Protection Fundamentals and Advancements

<http://www.selinc.com/techpprs/6163.pdf>

Zero-Setting Power-Swing Blocking Protection

[http://www.selinc.com/techpprs/6172 ZeroSetting 20050302.pdf](http://www.selinc.com/techpprs/6172_ZeroSetting_20050302.pdf)

Relay Performance During Major System Disturbances

[http://www.selinc.com/techpprs/6244 RelayPerformance DT 20060914.pdf](http://www.selinc.com/techpprs/6244_RelayPerformance_DT_20060914.pdf)

Thank You