

ZERO-SETTING POWER-SWING BLOCKING PROTECTION

Gabriel Benmouyal
Schweitzer Engineering
Laboratories, Inc.
Longueuil, Québec CANADA

Daqing Hou
Schweitzer Engineering
Laboratories, Inc.
Boise, ID USA

Demetrios Tziouvaras
Schweitzer Engineering
Laboratories, Inc.
Vacaville, CA USA

ABSTRACT

Modern distance relays have integrated numerous protection functions including power-swing blocking and out-of-step or pole-slip tripping functions. The main purpose of the power-swing blocking function is to differentiate faults from power swings and block distance or other relay elements from operating during stable or unstable power swings. Most power-swing blocking elements are based on traditional methods that monitor the rate of change of the positive-sequence impedance. The required settings for the power-swing blocking elements could be difficult to calculate in many applications, particularly those where fast swings can be expected. For these cases, extensive stability studies are necessary to determine the fastest rate of possible power swings.

This paper describes a zero-setting power-swing blocking protection method that is independent of network parameters and is based on monitoring the line swing-center voltage rate of change. The new method does not require any stability studies or user settings for the proper blocking of relay elements that are prone to operate during stable or unstable power swings. The method is applicable to long, heavily loaded transmission lines that pose great problems in the application of power-swing blocking elements based on traditional methods. This new method offers a great advantage in its ability to detect three-phase faults that may occur during power swings and allows the protective relays to issue a tripping command and isolate the faulted power system element. In this paper, we discuss other enhancements in the design of power-swing blocking and out-of-step tripping functions that improve the security and reliability of the power system. We also demonstrate the behavior and performance of the new power-swing blocking element through use of electromagnetic transient program (EMTP) and relay simulations.

INTRODUCTION

Power systems under steady-state conditions operate typically close to their nominal frequency. A balance between generated and consumed active power exists during steady-state operating conditions. Power system faults, line switching, generator disconnection, and the loss or application of large blocks of load result in sudden changes to electrical power, whereas the mechanical power input to generators remains relatively constant. These system disturbances cause oscillations in machine rotor angles and can result in severe power flow swings. Depending on the severity of the disturbance and the actions of power system controls, the system may remain stable and return to a new equilibrium state experiencing what is referred to as a stable power swing. Severe system disturbances, on the other hand, could cause large separation of generator rotor angles, large swings of power flows, large fluctuations of voltages and currents, and eventual loss of synchronism between groups of generators or between neighboring utility systems.

Large power swings, stable or unstable, can cause unwanted relay operations at different network locations, which can aggravate further the power-system disturbance and cause major power

outages or power blackouts. A power-swing blocking (PSB) function is available in modern distance relays to prevent unwanted distance relay element operation during power swings. The main purpose of the PSB function is to differentiate between faults and power swings and block distance or other relay elements from operating during a power swing. However, faults that occur during a power swing must be detected and cleared with a high degree of selectivity and dependability. In such situations, the PSB function should unblock and allow the distance relay elements to operate and clear any faults that occur in their zone of protection during a power-swing condition. Most PSB elements are based on traditional methods that monitor the rate of change of the positive-sequence impedance. The required settings for the PSB elements could be difficult to calculate in many applications, particularly those where fast swings can be expected. For these cases, extensive stability studies are necessary to determine the fastest rate of possible power swings.

Large power system disturbances can lead to loss of synchronism among interconnected power systems. If such a loss of synchronism occurs, it is imperative that the system areas operating asynchronously are separated immediately to avoid wide area blackouts and equipment damage. An out-of-step tripping (OST) function is available in modern distance relays to differentiate between stable and unstable power swings. During unstable power swings, the OST function initiates controlled tripping of appropriate breakers at predetermined network locations, to separate networks quickly and in a controlled manner in order to maintain power system stability and service continuity. Distance relay elements prone to operate during unstable power swings should be inhibited from operating to prevent system separation from occurring at random and in other than preselected locations. Traditionally, OST functions monitor the rate of change of the positive-sequence impedance. The required settings for the OST function are difficult to calculate, and in most applications, an extensive number of power system stability studies with different operating conditions must be performed. This is a costly exercise, and one can never be certain that all possible scenarios and operating conditions were considered.

In this paper, we discuss the design of a zero-setting PSB protection method that is independent of network parameters and is based on monitoring the line positive-sequence swing-center voltage rate of change. Note that the rate of change of the positive-sequence impedance is dependent upon the network parameters, i.e., transmission lines, transformers, and source impedances. The new method does not require any stability studies or user settings for the proper blocking of relay elements that are prone to operate during stable or unstable power swings. The method is applicable to long, heavily loaded transmission lines that pose significant problems to the application of power-swing blocking elements based on traditional methods. The new method can track a power swing regardless of the location of apparent impedance in the complex plane. This method offers a great advantage in its ability to detect three-phase faults that may occur during power swings and allows the protective relays to issue a tripping command and isolate the faulted power system element. We present additional enhancements in the design of PSB and OST functions that improve the security and reliability of the power system, and we demonstrate the behavior and performance of the new PSB element through use of EMTP and relay simulations.

THE FUNDAMENTAL POWER-SWING DETECTION PROBLEM

Power swings are variations in power flow that occur when the internal voltages of generators at different locations of the power system slip relative to each other. The change in power flow that occurs after clearing of a system fault is one form of a power swing. Power swings can cause the impedance presented to a distance relay to fall within its operating characteristics, away from the

preexisting steady-state load condition, and cause an undesired tripping of a transmission line. Distance relays should not trip during power swings, so that the power system can obtain a new equilibrium and return to a stable condition. On the other hand, utilities designate certain network points as separation points and apply OST schemes to separate system areas during unstable power swings or out-of-step (OOS) conditions.

The philosophy of power-swing protection is simple and straightforward: avoid tripping of any power system element during stable power swings. Protect the power system during unstable power swings or OOS conditions. Traditionally, two basic types of functions are available to deal with power-swing detection and system separation during unstable power swings or OOS conditions. The PSB function is designed to detect power swings, differentiate power swings from faults, and block distance relay elements from tripping during power swings. The PSB function prevents system elements from tripping at random and at unwanted source-voltage phase-angle difference between systems that are in the process of losing synchronism with each other.

When two areas of a power system, or two interconnected systems, lose synchronism, the areas must be separated from each other quickly and automatically to avoid equipment damage and shutdown of major portions of the power system. The OST function accomplishes this separation. The main purpose of the OST function is to detect stable from unstable power swings and initiate system area separation at the proper network locations and at the appropriate source-voltage phase-angle difference between systems. Ideally, the systems should be separated in such locations as to maintain a load-generation balance in each of the separated areas. System separation does not always achieve the desired load-generation balance. In cases where the separated area load is in excess of local generation, some form of nonessential load shedding is necessary to avoid a complete blackout of the area. Uncontrolled tripping of circuit breakers during an OOS condition could cause equipment damage and pose a safety concern for utility personnel. Therefore, a controlled tripping of certain power system elements is necessary to prevent equipment damage and widespread power outages and to minimize the effects of the disturbance.

The difference in the rate of change of the impedance vector has been used traditionally to detect a stable power swing or an OOS condition and block the operation of distance protection elements before the impedance enters the protective relay operating characteristics. This detection method is based on the fact that it takes a certain time for the rotor angle to advance because of system inertias. In other words, the rate of change of the impedance vector is slow during stable or unstable power swings, because it takes a finite time for the generator rotors to change position with respect to each other because of their large inertias. On the contrary, the rate of change of the impedance vector is very fast during a system fault. Actual implementation of measuring the impedance rate of change is normally performed through the use of two impedance measurement elements together with a timing device. If the measured impedance stays between the two impedance measurement elements for a predetermined time, the relay declares a power-swing blocking condition and issues a power-swing blocking signal to block the distance relay element operation.

CONVENTIONAL BLINDER-BASED PSB SCHEMES

Conventional PSB schemes are based mostly on measuring the positive-sequence impedance at a relay location. During system normal operating conditions, the measured impedance is the load impedance, and its locus is away from the distance relay protection characteristics. When a fault occurs, the measured impedance moves immediately from the load impedance location to the

location that represents the fault on the impedance plane. During a system fault, the rate of impedance change is determined primarily by the amount of signal filtering in the relay. During a system swing, the measured impedance moves slowly on the impedance plane, and the rate of impedance change is determined by the slip frequency of an equivalent two-source system. Conventional PSB schemes use the difference between impedance rate of change during a fault and during a power swing to differentiate between a fault and a swing. To accomplish this differentiation, one typically places two concentric impedance characteristics, separated by impedance ΔZ , on the impedance plane and uses a timer to time the duration of the impedance locus as it travels between them. If the measured impedance crosses the concentric characteristics before the timer expires, the relay declares the event a system fault. Otherwise, if the timer expires before the impedance crosses both impedance characteristics, the relay classifies the event as a power swing.

Over time, different impedance characteristics have been designed for power-swing detection. These characteristics include the double blinders shown in Figure 1(a), polygons in Figure 1(b), and concentric circles in Figure 1(c).

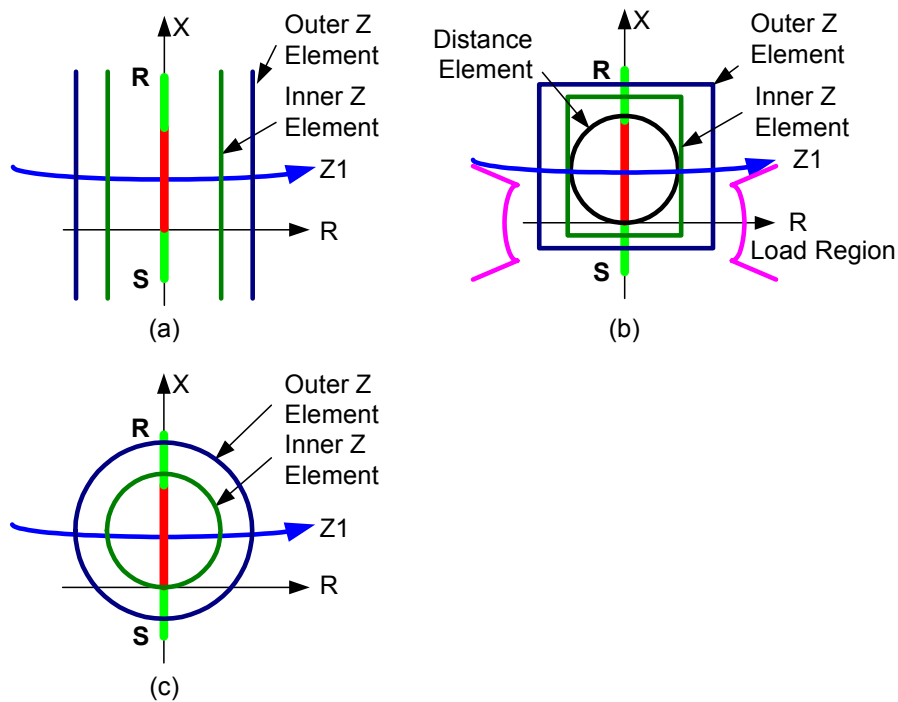

Figure 1 Conventional Blinder Schemes for Power-Swing Detection

There are a number of issues one must address with regards to properly applying and setting the traditional PSB and OST relaying functions. To guarantee that there is enough time to carry out blocking of the distance elements after a power swing is detected, the PSB inner impedance element must be placed outside the largest distance protection characteristic one wants to block. The PSB outer impedance element must be placed away from the load region to prevent PSB logic operation caused by heavy loads, thus establishing an incorrect blocking of the line who tripping elements. These relationships among the impedance measurement elements are shown in Figure 1(b), in which we use concentric polygons as PSB-detection elements.

The above requirements are difficult to achieve in some applications, depending on the relative line- and source-impedance magnitudes. Figure 2 shows a simplified representation of one line interconnecting two generating sources in the complex plane with a swing locus bisecting the

total impedance. Figure 2(a) depicts a system in which the line impedance is large compared to system impedances, and Figure 2(b) depicts a system in which the line impedance is much smaller than the system impedances.

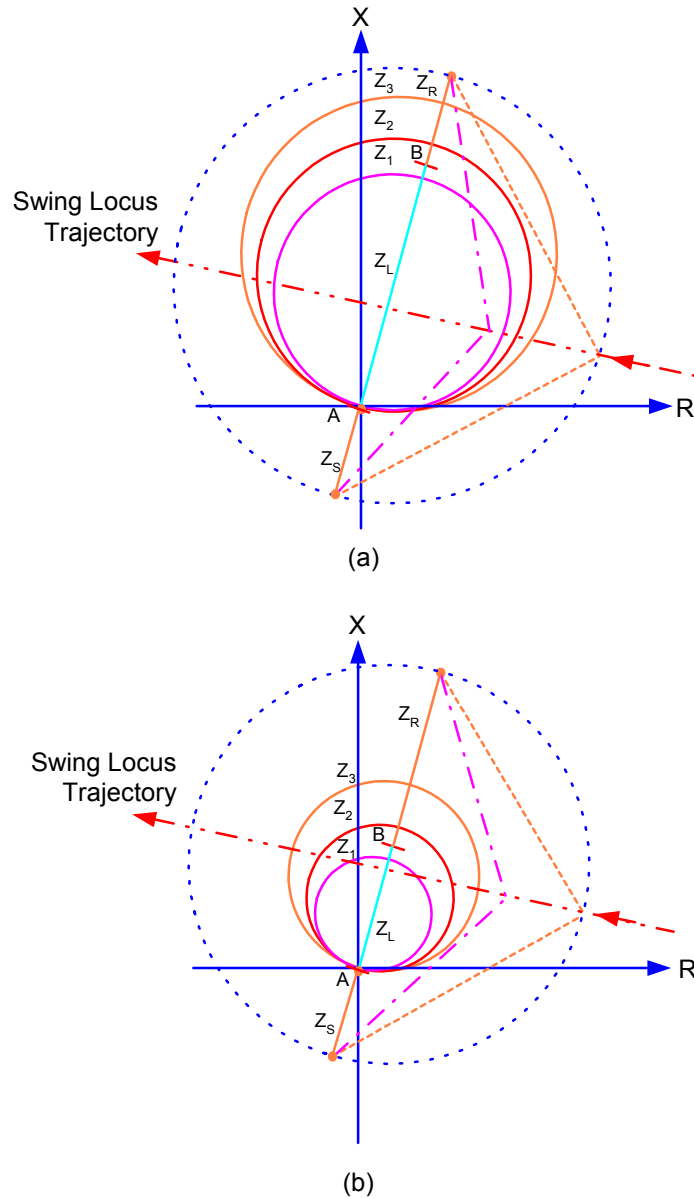

Figure 2 Effects of Source and Line Impedance on the PSB Function

We can observe from Figure 2(a) that the swing locus could enter the Zone 2 and Zone 1 relay characteristics before the phase-angle difference of the source voltages reaches 120 degrees, i.e., even during a stable power swing from which the system could recover. For this particular system, it may be difficult to set the inner and outer PSB impedance elements, especially if the line is heavily loaded, because the necessary PSB settings are so large that the load impedance could establish incorrect blocking. To avoid incorrect blocking resulting from load, lenticular distance relay characteristics, or blinders that restrict the tripping area of the mho elements, were applied in the past. On the other hand, the system shown in Figure 2(b) becomes unstable before

the swing locus enters the Zone 2 and Zone 1 relay characteristics, and it is relatively easy to set the inner and outer PSB impedance elements.

Another difficulty with traditional PSB systems is the separation between the PSB impedance elements and the timer setting that is used to differentiate a fault from a power swing. The above settings are not trivial to calculate and, depending on the system under consideration, it may be necessary to run extensive stability studies to determine the fastest power swing and the proper PSB impedance element settings. The rate of slip between two systems is a function of the accelerating torque and system inertias. In general, a relay cannot determine the slip analytically because of the complexity of the power system. However, by performing system stability studies and analyzing the angular excursions of systems as a function of time, one can estimate an average slip in degrees/s or cycles/s. This approach may be appropriate for systems whose slip frequency does not change considerably as the systems go out of step. However, in many systems where the slip frequency increases considerably after the first slip cycle and on subsequent slip cycles, a fixed impedance separation between the PSB impedance elements and a fixed time delay may not be suitable to provide a continuous blocking signal to the mho distance elements.

Hou et al. [1] detailed steps for setting a polygon characteristic. These settings guidelines are applicable to all other blinder schemes shown in Figure 1 and are outlined as follows.

1. Set the outer characteristic resistive blinders inside the maximum possible load with some safety margin as illustrated in Figure 1(b).
2. Set the inner resistive blinders outside the most overreaching protection zone that is to be blocked when a swing condition occurs. Normally, you want to block the distance elements that issue a trip without a time delay. These elements include the Zone 1 instantaneous tripping element and the Zone 2 element that is used in a communications-assisted tripping scheme.
3. Based on the outer and inner blinders set in the previous steps, the PSB timer value, OSBD, can be calculated from the following equation with information of the local source impedance, $Z1S$, the line impedance, $Z1L$, and the remote source impedance, $Z1R$. $\text{Ang}6R$ and $\text{Ang}5R$ are machine angles at the outer and inner blinder reaches, respectively, as illustrated in Figure 3. The maximum slip frequency, F_{slip} , is also assumed in the calculation. Typical maximum slip frequency is chosen anywhere between from 4 to 7 Hz.

$$\text{OSBD} = \frac{(\text{Ang}5\text{R} - \text{Ang}6\text{R}) \cdot \text{Fnom}(\text{Hz})}{360 \cdot \text{Fslip}(\text{Hz})} (\text{cycle})$$

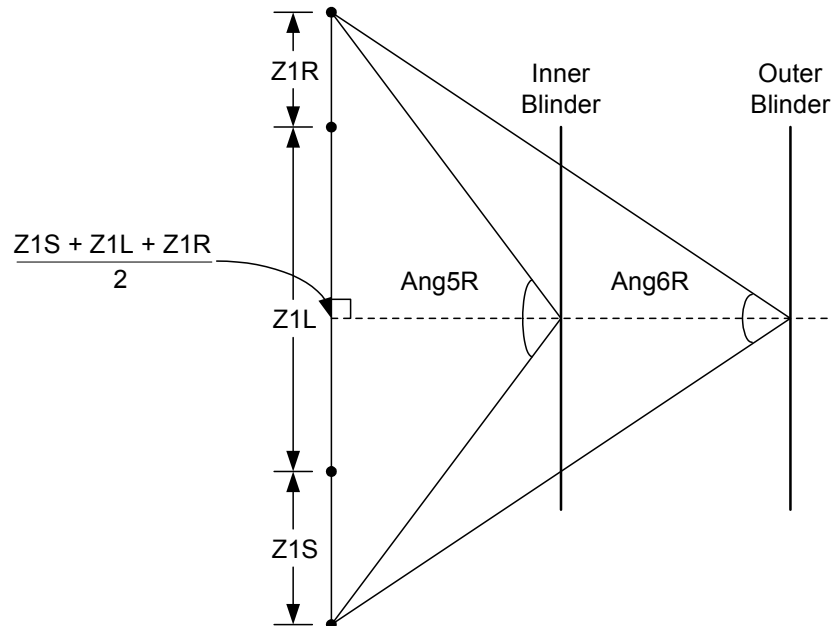

Figure 3 Equivalent Two-Source Machine Angles During OOS

It is very difficult in a complex power system to obtain the proper source impedance values, as shown in Figure 3, that are necessary to establish the blinder and OSBD timer settings. The source impedances vary constantly according to network changes, such as, for example, additions of new generation and other system elements. The source impedances could also change drastically during a major disturbance and at a time when the PSB and OST functions are called upon to take the proper actions. Note that the design of the PSB function would have been trivial if the source impedances remained constant and if it were easy to obtain them. Normally, very detailed system stability studies are necessary to consider all contingency conditions in determining the most suitable equivalent source impedance to set the conventional PSB function.

Other than needing careful system studies and detailed source parameters, one may also experience difficulties for a long line with heavy loads, where the load region is close to the distance element that needs to be blocked in a swing condition. In this condition, the spacing between the inner and outer blinders may be small enough to cause a significant timing error for a power swing. If the load region encroaches the distance element one wants to block under swings, then it is impossible to place the PSB characteristics between the load and distance regions, and one cannot apply the conventional PSB blocking function.

SWING-CENTER VOLTAGE AND ITS LOCAL ESTIMATE, $V_{\text{COS}\phi}$

Swing-Center Voltage

Swing-center voltage (SCV) is defined as the voltage at the location of a two-source equivalent system where the voltage value is zero when the angles between the two sources are 180 degrees apart. Figure 4 illustrates the voltage phasor diagram of a general two-source system, with the SCV shown as the phasor from origin o to the point o' .

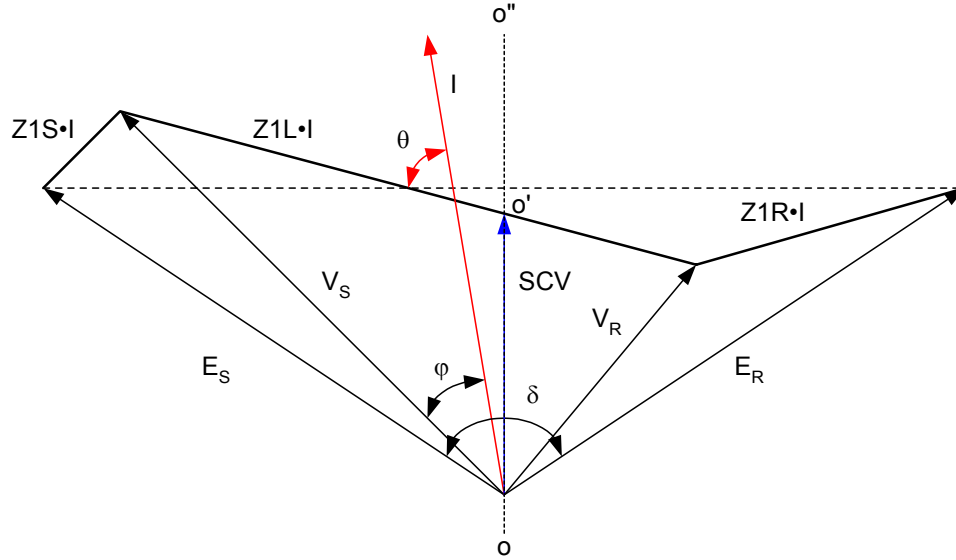

Figure 4 Voltage Phasor Diagram of the Two-Source System

When a two-source system loses stability and goes into an OOS situation after some disturbance, the angle difference of the two sources, $\delta(t)$, will increase as a function of time. As derived in detail in the Appendix, we can represent the SCV by Equation (1), assuming an equal source magnitude, E .

$$SCV(t) = \sqrt{2}E \sin\left(\omega t + \frac{\delta(t)}{2}\right) \cdot \cos\left(\frac{\delta(t)}{2}\right) \quad (1)$$

$SCV(t)$ is the instantaneous SCV that is to be differentiated from the SCV that we estimate locally in the following pages. Equation (1) is a typical amplitude-modulated sinusoidal waveform. The first sine term is the base sinusoidal wave, or the carrier, with an average frequency of $\omega + (1/2)(d\delta/dt)$. The second term is the cosine amplitude modulation.

Figure 5 shows a positive-sequence SCV with an average frequency of 50 Hz and a constant slip frequency of 5 Hz. When the frequency of a sinusoidal input is different from that assumed in its phasor calculation, as is in the case of an OOS situation, oscillations in the phasor magnitude result. However, the magnitude calculation in Figure 5 is smooth because the positive-sequence quantity effectively averages out the magnitude oscillations of individual phases.

The magnitude of the swing-center voltage changes between zero and one per unit of system nominal voltage. With a slip frequency of 5 Hz, the voltage magnitude is forced to zero every 0.2 seconds. We should emphasize that Figure 5 shows SCV during a system OOS condition. In a normal load condition, the magnitude of the SCV stays constant.

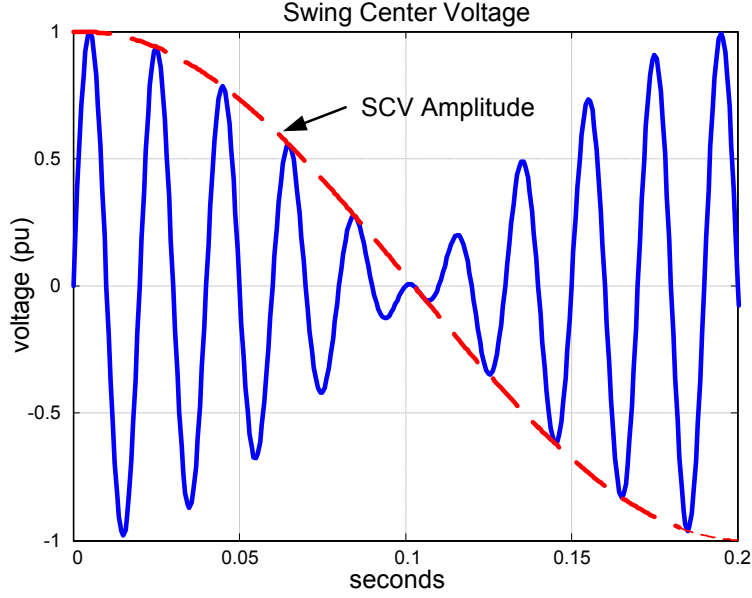

Figure 5 Swing-Center Voltage During an OOS Condition

For the purpose of detecting power system swings, the SCV has the following advantages:

1. The SCV is independent of the system source and line impedances and is, therefore, particularly attractive for use in a no-setting power-swing blocking function. On the contrary, other quantities, such as the resistance and its rate of change and the real power and its rate of change, depend on the line and system-source impedances and other system parameters that make them less suitable for use in a no-setting power-swing function.
2. The SCV is bounded with a lower limit of zero and an upper limit of one per unit, regardless of system impedance parameters. This is in contrast to other electrical quantities, such as impedance, currents, and active or reactive powers, whose limits depend on a variety of system parameters.
3. The magnitude of the SCV relates directly to δ , the angle difference of two sources. For example, if the measured magnitude of swing-center voltage is half of the nominal voltage, then δ is 120 degrees, assuming equal source magnitudes and a homogeneous system.

SCV Local Estimate: $V \cos \varphi$

One popular approximation of the SCV obtained through use of locally available quantities is as follows:

$$SCV \approx |V_S| \cdot \cos \varphi \quad (2)$$

where $|V_S|$ is the magnitude of locally measured voltage, and φ is the angle difference between V_S and the local current as shown in Figure 6. In Figure 6, we can see that $V \cos \varphi$ is a projection of V_S onto the axis of the current, I . For a homogeneous system with the system impedance angle, θ , close to 90 degrees, $V \cos \varphi$ approximates well the magnitude of the swing-center voltage. For the purpose of power-swing detection, it is the rate of change of the SCV that provides the main information of system swings. Therefore, some differences in magnitude between the system SCV and its local estimate have little impact in detecting power swings. We will, therefore, refer

to $V\cos\phi$ as the SCV in the following discussion. The quantity of $V\cos\phi$ was first introduced by Ilar [2] in detecting power swings.

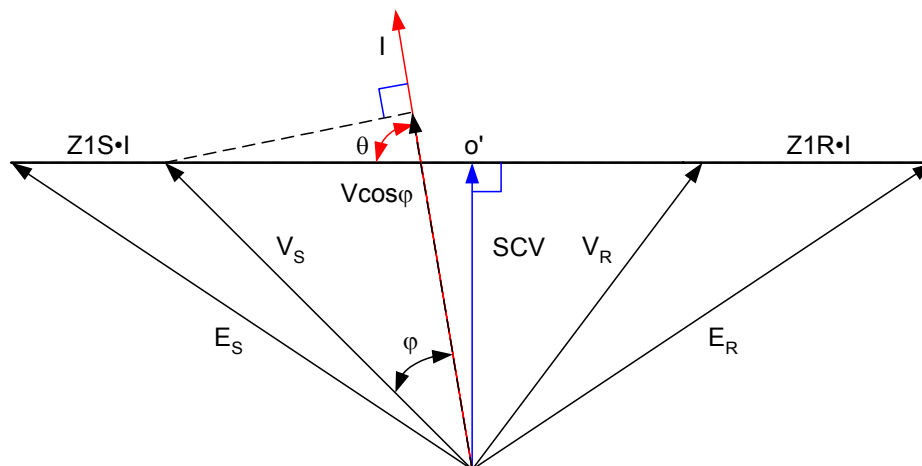

Figure 6 $V\cos\phi$ Is a Projection of Local Voltage, V_S , Onto Local Current, I

From Equation (1) and by keeping in mind that the local SCV estimation is using the magnitude of the local voltage, the relation between the SCV and the phase-angle difference, δ , of two source-voltage phasors can be simplified to the following:

$$SCV1 = E1 \cdot \cos\left(\frac{\delta}{2}\right) \quad (3)$$

In this last expression, $E1$ is the positive-sequence source magnitude equal to E_S that is assumed to be also equal to E_R . We use $SCV1$ to represent the fact that we shall use the positive-sequence swing-center voltage in the power-swing detection for the benefit of its smooth magnitude during system OOS. The absolute value of the SCV is at its maximum when the angle between the two sources is zero, and this value is at its minimum (or zero) when the angle is 180 degrees. This property has been exploited so one can detect a power swing by looking at the rate of change of the swing-center voltage. The time derivative of $SCV1$ then becomes the following:

$$\frac{d(SCV1)}{dt} = -\frac{E1}{2} \sin\left(\frac{\delta}{2}\right) \frac{d\delta}{dt} \quad (4)$$

Equation (4) provides the relation between the rate of change of the SCV and the two-machine system slip frequency, $d\delta/dt$. Note that the derivative of the SCV voltage is independent from the network impedances and that it reaches its maximum when the angle between the two machines is 180 degrees. When the angle of the two machines is zero, the rate of change of the SCV is also zero. The maximum value of the derivative of the SCV occurs when δ is 180 degrees. In Figure 7, $SCV1$ and the rate of change of $SCV1$ are plotted, assuming a constant slip frequency of 1 rad/s.

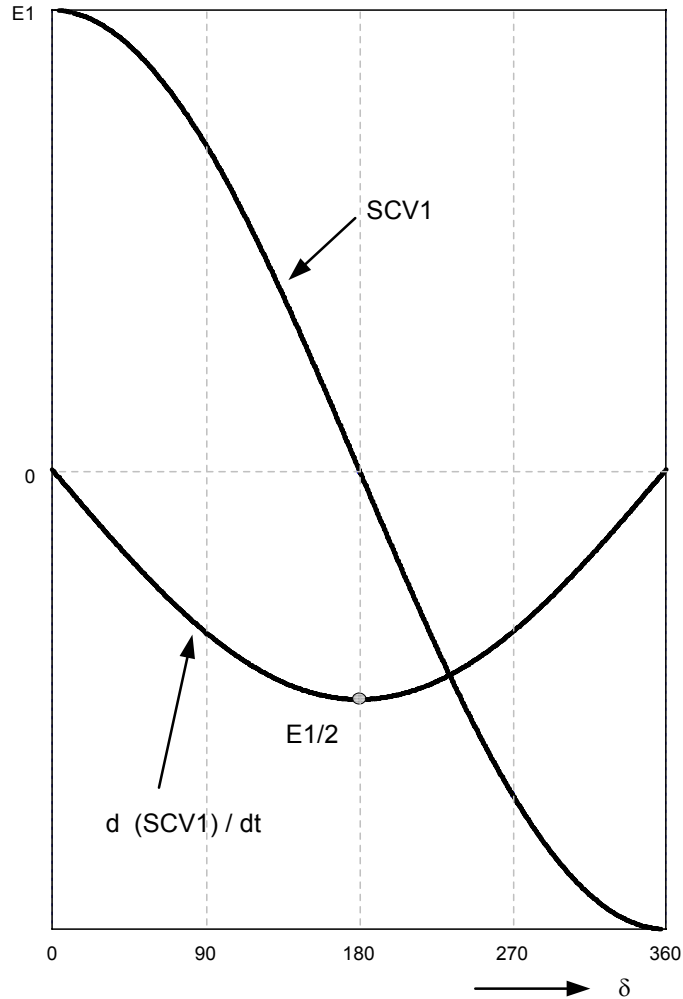

Figure 7 SCV1 and Its Rate of Change With Unity Source Voltage Magnitudes

Before leaving this section, we want to point out the following two differences between the system swing-center voltage and its local estimate. Again, these magnitude differences do not impact the power-swing detection that is based mainly on the rate of change of the SCV:

1. When there is no load flowing on a transmission line, the current from a line terminal is basically the line-charging current that leads the local terminal voltage by about 90 degrees. In this case, the local estimate of the SCV is close to zero and does not represent the true system swing-center voltage.
2. The local estimate of the SCV has a sign change in its value when the difference angle, δ , of two equivalent sources goes through zero degrees. This sign change results from the reversal of the line current. That is, ϕ changes 180 degrees when δ goes through the 0-degree point. The system swing-center voltage does not have this discontinuity.

A POWER-SWING DETECTOR BASED ON THE POSITIVE-SEQUENCE SWING-CENTER VOLTAGE RATE OF CHANGE

Power-Swing Blocking Detection Logic

The power-swing blocking function is based on three functions to detect a power swing. These functions are the swing-center voltage slope detector, the swing signature detector, and the dependable PSB detector. The block-diagram of the PSB function is shown in Figure 8.

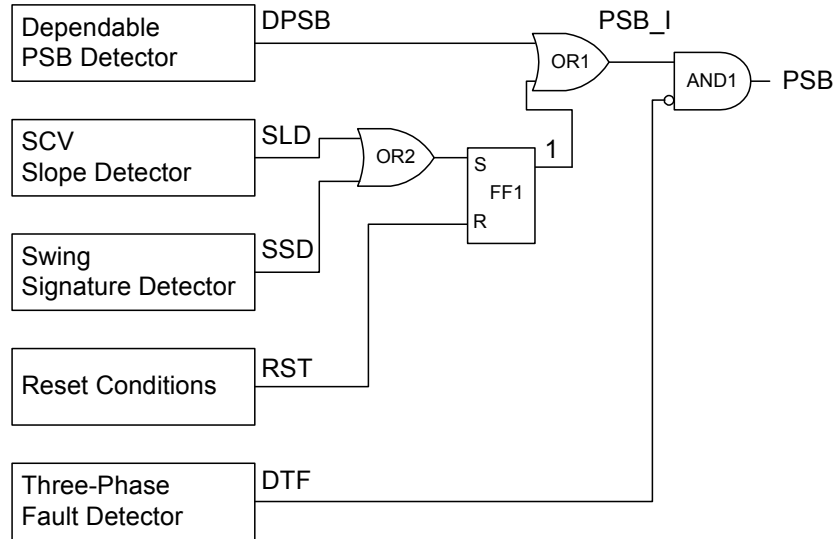

Figure 8 Basic Power-Swing Blocking Logic Function

A simplified logic diagram of the slope detector is shown in Figure 9. The slope detector monitors the absolute value of the positive-sequence swing-center voltage (SCV1) rate of change, the magnitude of the SCV1, and the output of a discontinuity detector, and generates a PSB signal when it measures a significant value of $|d(SCV1)/dt|$ as would happen during a power swing. For the slope detector to produce an output, the absolute value of the rate of change of SCV1 must be above a minimum threshold (Min_dSCV1), the magnitude of the SCV1 must be within a maximum (Thr_Hi) and a minimum (Thr_Low) threshold, and the positive-sequence impedance measured by the distance relay must reside within a starter zone. The output of the slope detector is blocked any time the absolute value of the rate of change of SCV1 is above a maximum threshold (Max_dSCV1) or the absolute value of the discontinuity detector is above a certain threshold (Thr_d2SCV1). The slope detector typically detects the majority of power-swing conditions. However, in some difficult situations that we will discuss later, the slope detector may not operate and, for this reason, we supplement the slope detector with two additional detectors we mentioned earlier: the swing signature and dependable PSB detectors.

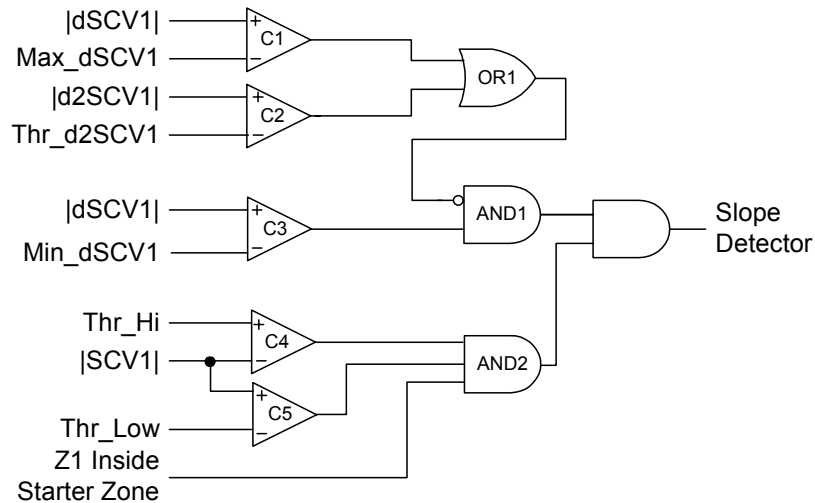

Figure 9 SCV1 Slope Detector Function

The minimum (Min_dSCV1) and maximum (Max_dSCV1) rate of change of SCV1 determine the measurement interval of the slip frequency of a classical two-generator equivalent system model. Noting that it is impossible mathematically to compute the slip frequency directly from the rate of change of SCV1, we set the limits of the interval of the rate of change of SCV1 with a security factor that guarantees that an interval of slip frequency from 0.1 to 7 Hz will be covered.

The first- and second-order time derivatives of SCV1 are computed as shown in Figure 10 and are used by the slope detector and swing signature detector logic functions. The second-order time derivative takes a very high value every time a discontinuity is present in the signal. This discontinuity could be present either because of the inherent discontinuities of SCV1 or because of some other event such as a fault that could occur on the network. All values of derivatives are computed in per-unit volts per cycle (V (pu)/cycle).

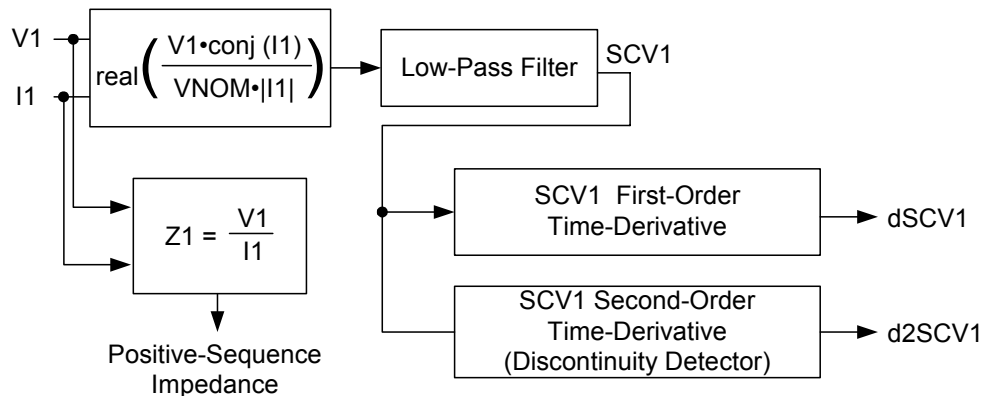

Figure 10 Principle of Swing-Center Voltage Derivatives

The Swing Signature Detector

The swing signature detector (SSD) complements the slope detector and supplements the dependable PSB logic in some cases. The basic principle of the swing signature detector is shown in Figure 11. It is based on the fact that if a fault detector picks up (rho-type elements essentially) during a power swing, no discontinuity will be present on the SCV1 signal prior to the detection because the fault detection is not the result of a real fault.

To implement this principle, as shown in Figure 11, the logic stores the absolute value of the first-order derivative, $dSCV1$, continuously in a buffer memory over an interval of a few cycles. The maximum value of this buffer memory is then established as $dSCV1_{MAX}$. If the detected fault is a real fault, this slope maximum value, $dSCV1_{MAX}$, will be very high because a discontinuity has occurred in the SCV1 waveform. A number of the older samples are then compared to this maximum value. If the fault is real, all these samples will be below a variable threshold that is proportional to the slope maximum value. If the fault is the result of a power swing, no discontinuity will appear in the buffer, all the compared old samples will be above the same variable threshold, and the SSD output will assert.

The swing signature detector is, therefore, an algorithm that distinguishes between a power swing and a real fault at the moment the outmost distance element, to be blocked by the swing detection, picks up. Note that the slope detector in a normal situation will detect a power swing first and then assert the PSB signal. The PSB signal, in turn, will block the mho fault detectors, and the SSD logic will not be processed.

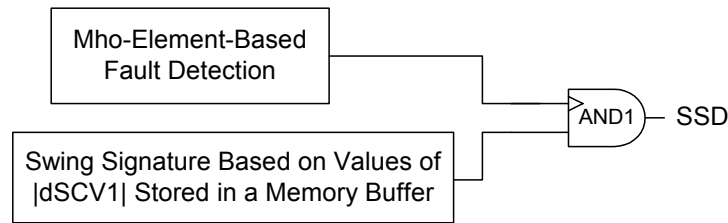

Figure 11 Swing-Signature Detection Principle

The Dependable Power-Swing Blocking Function

The dependable PSB (DPSB) function will assert the PSB signal in situations where neither the slope detector nor the swing signature detector can detect a power swing fast enough. This will happen particularly after a lasting external fault has been cleared and the network embarks into a power-swing situation. The dependable PSB function issues a temporary PSB signal and, after some delay, the slope detector detects any power swing in the network. Therefore, the purpose of the dependable power-swing detector is to supply a temporary DPSB signal that will assert the PSB bit to compensate for the pickup delay of the slope detector.

An example of this type of situation might occur after a long-lasting fault right behind or at the remote end of a transmission line on a marginally stable network. As shown in Figure 12, if a close reverse or forward fault clears with a significant delay, there is a possibility that the network has entered a power swing. If such a circumstance unfolds, the Z1 trajectory at the relay could cross a Zone 2 or Zone 1 phase-mho detector right after the fault clears and without the power swing being detected. The phase mho elements of the relay could then issue a trip signal as a result of the power swing and not because of a real fault.

As a general rule, for an external forward fault, the logic issues a DPSB signal if the signal from a fault detector has lasted several cycles, no power swing has been detected, the relay has issued no trip, and at least one of the Zone 1 phase-mho has picked up. For a reverse fault, the logic issues a DPSB signal if a power swing has not been detected, the signal from a fault detector has lasted several cycles and been cleared, the relay has issued no trip signal, and a Zone 2 mho-phase has picked up within a time delay.

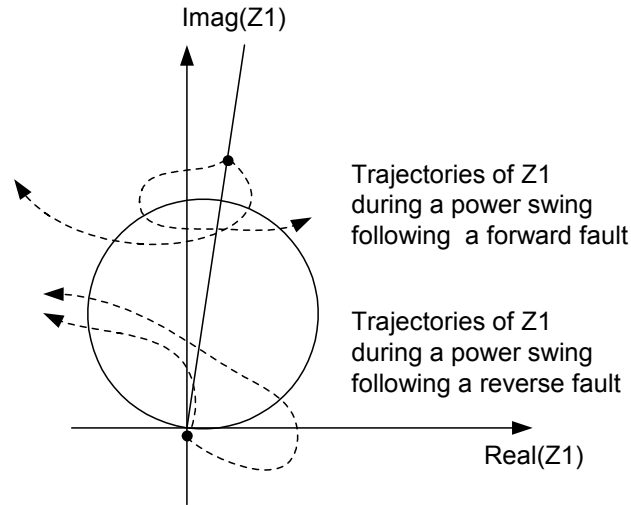

Figure 12 Type of Faults Detected by the DPSB Function

The Three-Phase Fault Detector

If a three-phase fault occurs on a transmission line during a power swing, a discontinuity will be present on the corresponding SCV1 waveform. This discontinuity can be monitored when the second derivative of SCV1 takes a higher than usual value. Furthermore, the SCV1 will take a low value and its rate of change will be very small. These properties are taken into account in the three-phase fault detector so as to implement a very fast detector, independent from the swing speed. Figure 13 shows a simplified logic diagram of the three-phase fault detector. Three-phase faults will be detected with a minimum and maximum time delay of two and five cycles, respectively.

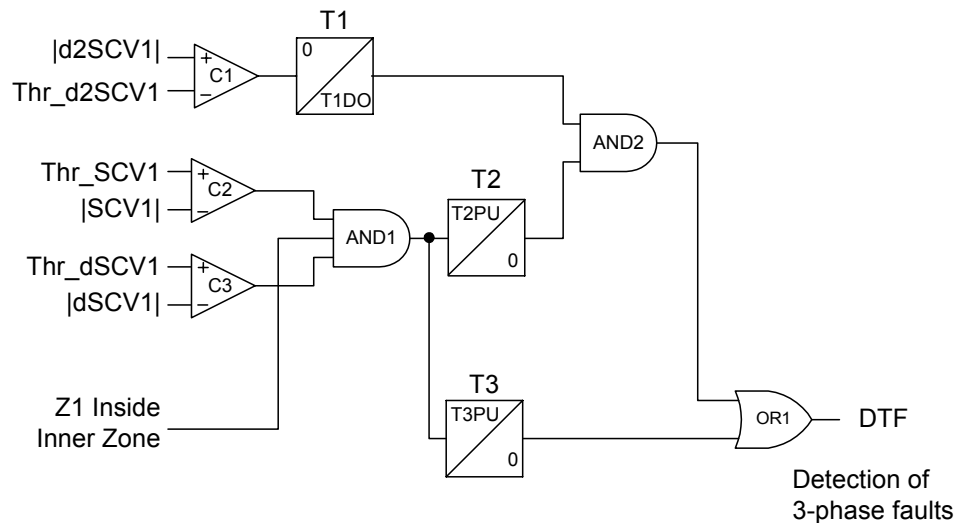

Figure 13 Detection of Three-Phase Faults Logic

The Reset Logic

When such conditions exist that allow inferring that the power swing has receded, the reset logic sends a reset signal to the main flip-flop in Figure 8. The main condition indicating a

disappearance of the power swing is the rate of change of the SCV1 signal taking a very small value (below Min_dSCV1). The reset logic is shown in Figure 14.

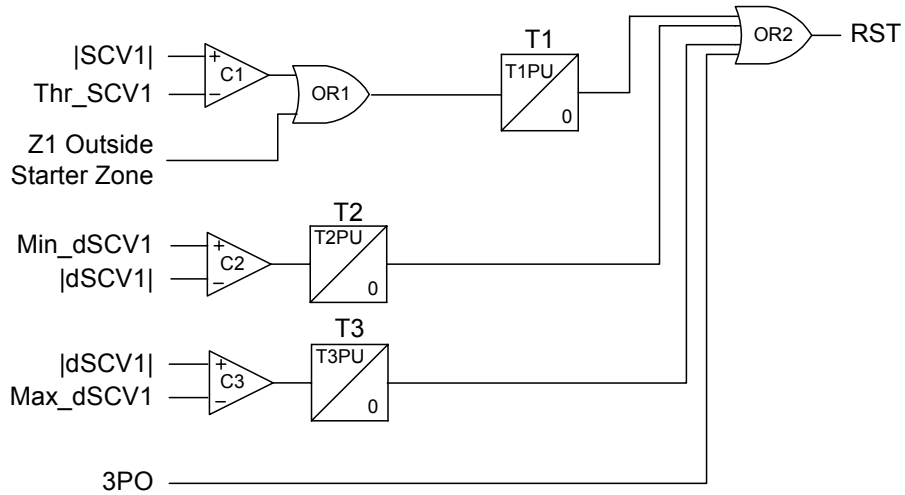

Figure 14 Reset Logic

The Starter Zone

The purpose of the starter zone is to reduce the sensitivity of the power-swing detector by allowing PSB to assert only for trajectories of the positive-sequence impedance, $Z1$, that have a chance to cross any mho element characteristic during a power swing.

The area covered by the starter zone is by no means critical and is defined as a rectangle, shown in Figure 15, the dimensions of which are automatically set so that it will encompass all the mho characteristics that have to be blocked during a power swing. The starter zone will also encompass the largest relay characteristic in use by the OST logic, if one enables the OST function.

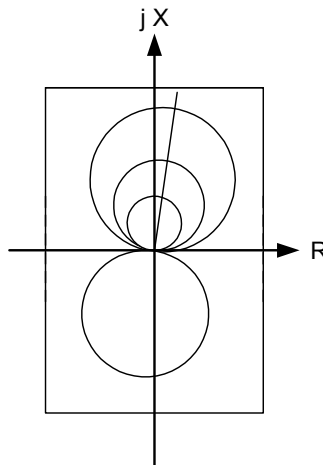

Figure 15 Starter Zone

PSB Reset Signals From Additional Fault Detectors

During a power swing, and if PSB is enabled, the PSB signal blocks only phase-fault detectors. Ground faults are not blocked because a power swing is considered a three-phase balanced phenomenon. It is necessary, therefore, to be able to detect three-phase and phase-to-phase faults to remove the PSB signal and allow clearing of a fault that occurs during a power swing.

We already discussed detection of three-phase faults. To detect phase-to-phase faults, a directional overcurrent element, 67QUB, based on a negative-sequence directional element, 32Q, is used as shown in Figure 16. In this figure, the 32Q directional element is supplemented with a check on the levels of positive- and negative-sequence currents. The logic impact of the 67QUB signal on the AB phase mho element is shown in Figure 17. In a normal situation, the PSB signal blocks the mho detector output MAB. When the 67QUB element asserts, the mho element can operate.

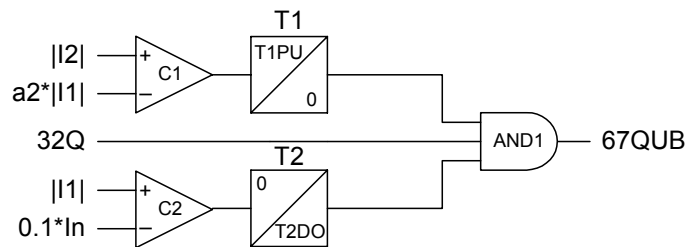

Figure 16 Negative-Sequence Directional Overcurrent Element, 67QUB

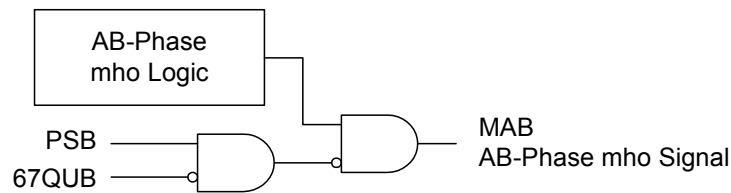

Figure 17 Unblocking of the MAB Signal by the 67QUB Element

When the relay detects a power swing during an open-pole situation, the ground-fault detectors must be blocked, because the power swing is no longer balanced, and it is very important to detect any subsequent fault. This is accomplished by supervising the angle of the phasors' ratio of the zero-sequence current over the negative-sequence current, as shown in Figure 18. As an example, if A-phase is open, the angle normally lies between -60 and 60 degrees. If a fault occurs on B- or C-phase or both, this relation no longer holds. This relation is used to unblock the ground-mho elements and allow a fault to be cleared. On Figure 19, OSBA will assert if B-phase or C-phase is open and no fault has been detected. If a fault occurs on B-phase or C-phase or both, OSBA will deassert because of the angle supervision. The same principle is applicable to OSBB and OSBC. The principle of unblocking the A-phase-to-ground mho detector is shown in Figure 20. When all three poles are closed, OSBA is not asserted and the element can trip normally even when PSB is set. When either B-phase or C-phase is open, the relay blocks the mho element for any detection of a power swing (OSBA asserted). The relay removes the blocking for any detection of a fault (OSBA deasserted).

Note that the previous current-ratio angle supervision will not work if a phase-to-phase-to-ground fault occurs during a pole-open operation. This is, however, tantamount to having a three-phase fault, for which the already described three-phase fault detector will operate as expected.

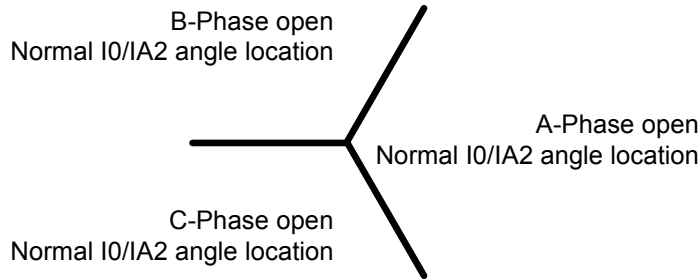

Figure 18 I0/IA2 Angle Supervision During Pole-Open Situation

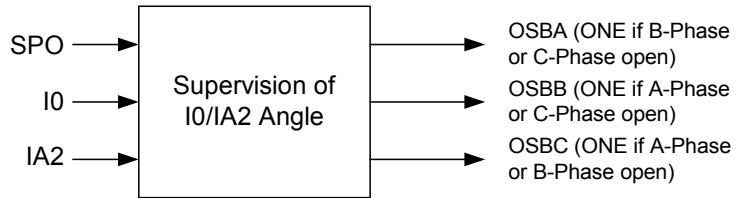

Figure 19 Fault-Detector Logic During a Pole-Open Situation

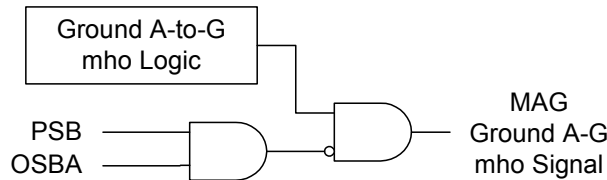

Figure 20 Unblocking of the MAG Signal by the OSBA Fault Detection

OUT-OF-STEP TRIPPING THROUGH USE OF THE NEW POWER-SWING DETECTION

Conventional OST schemes are also based on the concept of the rate of change of the measured impedance vector during a power swing. The OST function is designed to differentiate between a stable and an unstable power swing and, if the power swing is unstable, to send a tripping command at the appropriate time to trip the line breakers. Traditional OST schemes use similar distance characteristics as the PSB schemes shown in Figure 1. OST schemes also use a timer to time how long it takes for the measured impedance to travel between the two characteristics. If the timer expires before the measured impedance vector travels between the two characteristics, the relay classifies the power swing as an unstable swing and issues a tripping signal.

One of the most important and difficult aspects of an OST scheme is the calculation of proper settings for the distance relay OST characteristics and the OST time-delay setting. One should be absolutely certain that a stable power swing never crosses the outermost OST characteristic, to avoid a system separation during a stable power swing from which the system can recover. To calculate the above settings, one must run extensive and expensive stability studies, and one can never be certain that all possible system scenarios have been considered. The other difficult aspect of OST schemes is to determine the appropriate time at which to issue a trip signal to the breaker to avoid equipment damage and to ensure personnel safety. To adequately protect the circuit breakers and ensure personnel safety, most utilities do not allow uncontrolled tripping during an out-of-step condition and restrict the operation of OST relays when the relative voltage angle between the two systems is less than 90 and greater than 270 degrees. This tripping is referred to as “Trip-on-the-Way-Out” (TOWO). Compared to “Trip-on-the-Way-In” (TOWI) to

be discussed below, TOWO has a softer impact on the breakers involved because the transient recovery voltage that results from tripping at a smaller angle between the two systems is more favorable.

In the past, stability studies in some interconnected power systems pointed out that waiting to trip until the relative phase angle of the two systems reached 270 degrees may cause instability of subregions within each utility system. Therefore, TOWO was not deemed to be fast enough, and new requirements were imposed to relay manufacturers to develop OST schemes that allowed systems to trip before they reach a relative phase angle of 90 degrees. This is referred to as TOWI. TOWI is useful in some systems to prevent severe voltage dips and potential loss of loads. TOWI is typically applied in very large systems whose angular movement with respect to one another is very slow and where there is a real danger that transmission line thermal damage may occur if tripping is delayed until a more favorable angle exists between the two systems. One should exercise care in such applications because the relay issues the tripping command to the circuit breakers when the relative phase angles of the two systems approach 180 degrees and because such applications result in greater circuit breaker trip duty than for TOWO applications.

All of the previously discussed OST setting complexities and the need for stability studies can be eliminated if the OST function uses as one of its inputs the output of a robust PSB function that makes certain that the network is experiencing a power swing and not a fault. The OST function, therefore, could be implemented to track and verify that the measured impedance trajectory crosses the complex impedance plane from right-to-left or from left-to-right and issue a TOWO at a desired phase-angle difference between sources. We have designed an OST function to take advantage of the reliable PSB bit and allow one to apply it with no need to perform any stability studies if one wants to apply TOWO. The OST function offers the following three options:

1. TOWO during the first slip cycle
2. TOWO after a set number of slip cycles has occurred
3. TOWI before completion of the first slip cycle

The OST scheme monitors and tracks the positive-sequence impedance, Z_1 , trajectory as it moves in the complex plane. Four resistive and four reactive blinders are still used in the OST scheme as shown in Figure 21, but the settings for these blinders are easy to calculate. The outermost OST resistive blinders can be placed almost anywhere in the complex impedance plane without concern regarding whether a stable power swing crosses these blinders or whether the load impedance of a long, heavily loaded line encroaches upon them. In addition, there are no OST timer settings involved in the new OST scheme. To use the infrequently applied TOWI option, one would still need to perform stability studies to obtain the proper OST relay settings.

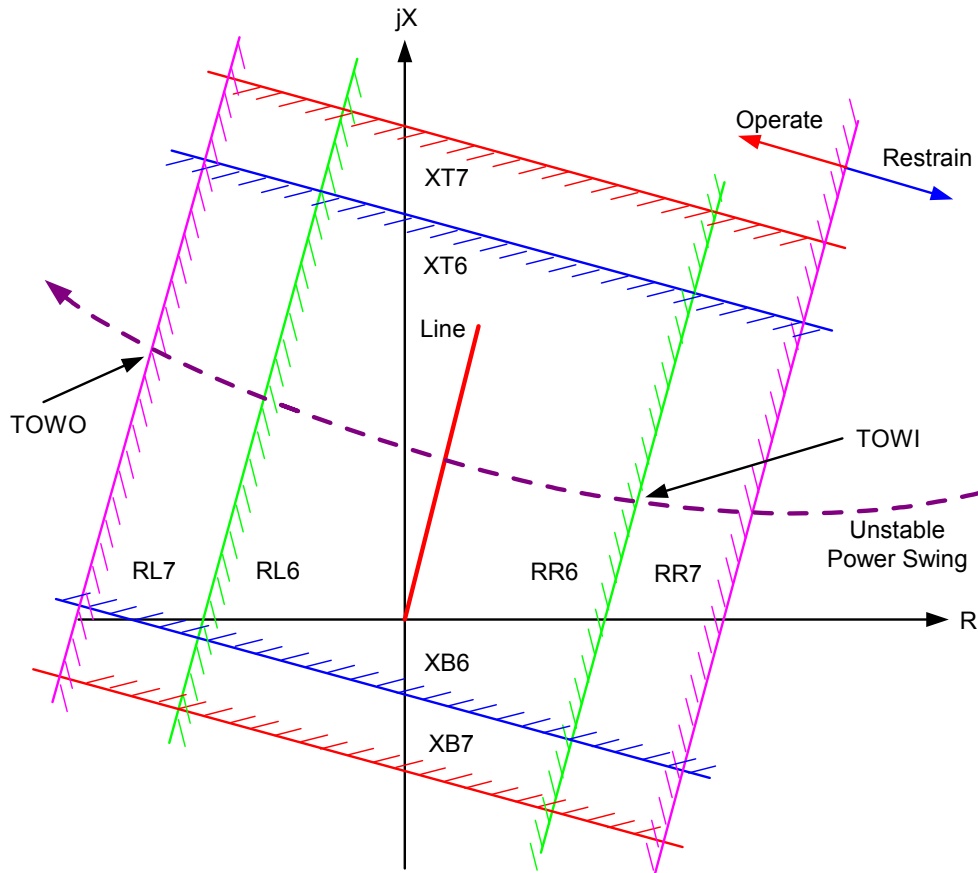

Figure 21 OST Scheme Blinder Characteristics

COMPUTER SIMULATION AND VERIFICATION

A relay computer model implements the power-swing detection algorithms the previous sections describe. Extensive tests on this relay model have ensured correct operation of the power-swing detection logic under different system configurations and operating conditions. A variety of EMTP simulation programs and some field digital fault recorder (DFR) records provided the data for these tests. This section describes some systems simulated in EMTP and shows some typical relay simulation results.

Example 1: OOS With All Poles Closed and an A-Phase Ground Fault

The system this example uses is a model of a 500 kV three-machine network with AVR controls modeled in all machines and a PSS modeled in Generator G1 as shown in Figure 22. Besides the classical one-machine infinite-source systems, it is necessary to model more complex power systems with multiple machines to observe and test the OOS algorithm on interactions among multiple machines. The waveforms from a multimachine system are more complex than the typical textbook waveforms one encounters in simple one-machine infinite-source systems or in very large networks that resemble those of two-machine systems, because, typically, one coherent group of machines in one network may be going into an out-of-step condition against another coherent group of machines in a different network.

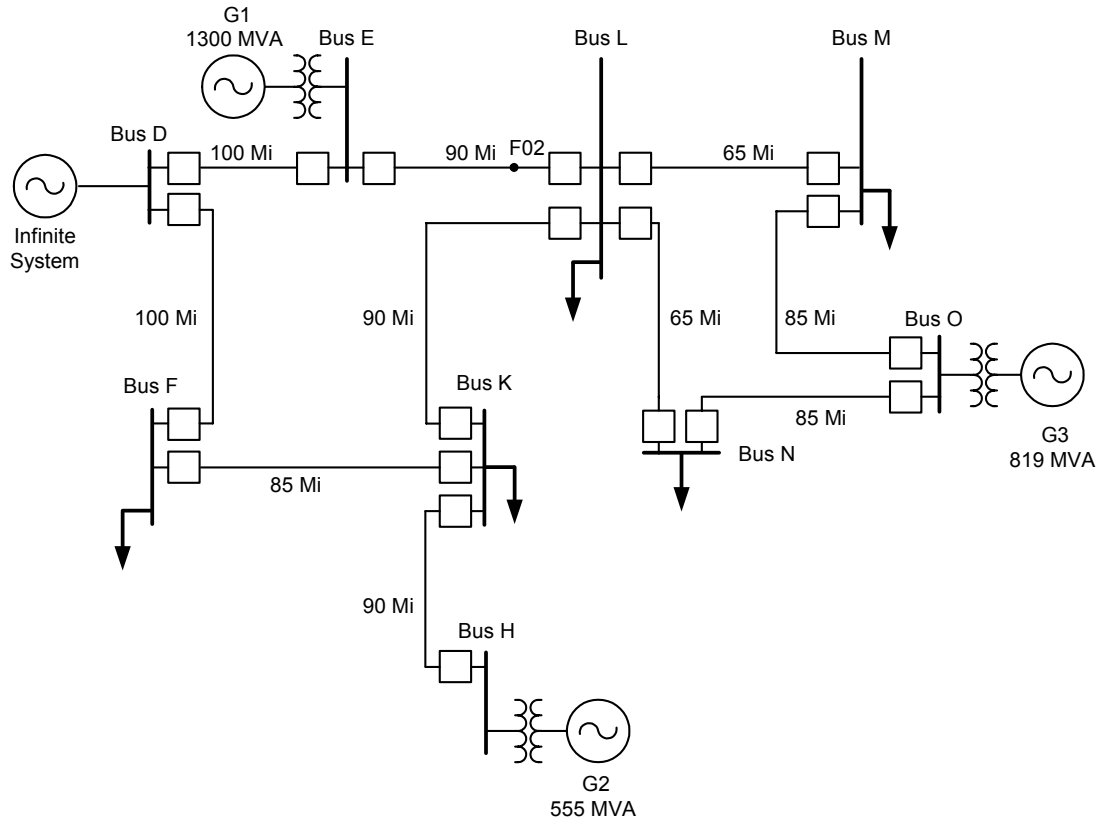

Figure 22 Multimachine System Used in Example 1

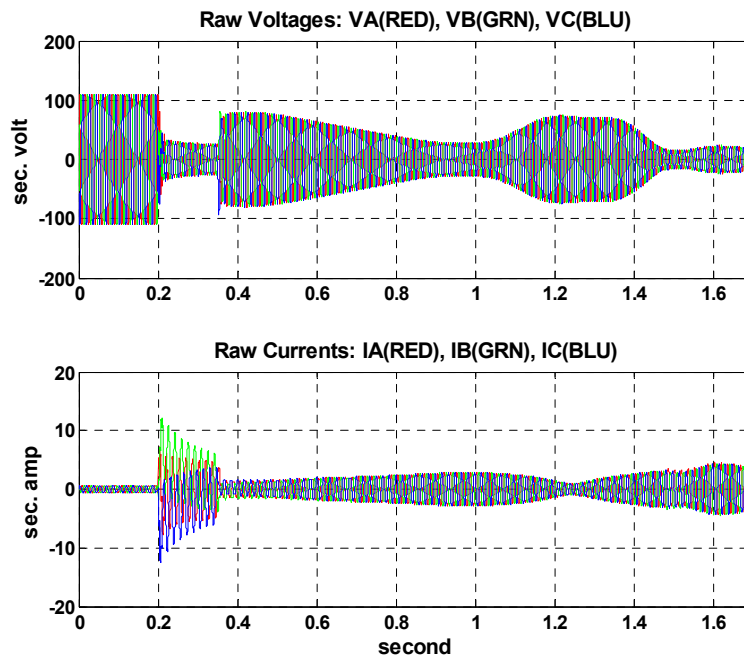

Figure 23 Voltage and Currents

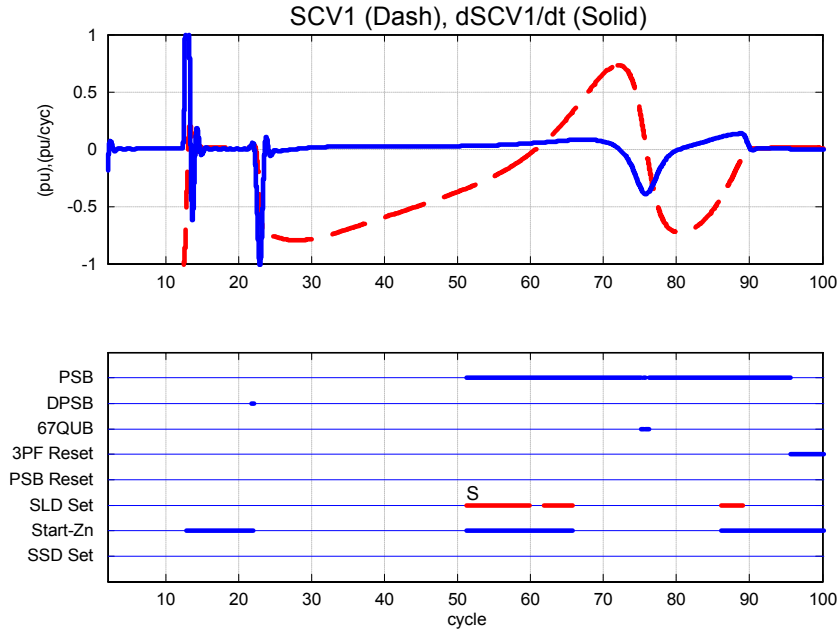

Figure 25 SCV and Power-Swing Blocking Elements

The upper plot in Figure 25 shows the positive-sequence SCV in a dashed line and the SCV derivative in a solid line. The prefault SCV in this case is close to one per unit. SCV drops to a value near zero during the three-phase fault because the transmission line angle is close to 90 degrees. SCV oscillates close to a sinusoidal pattern after the three-phase fault clears and the system goes into OOS. The SCV goes to zero when the evolving three-phase fault occurs at about cycle 90.

The lower plot of Figure 25 shows the OOS protection element operations of the proposed algorithm. A thicker line on top of a reference thin line indicates a logical 1 output for an element. Table 1 lists the elements on the plot and the element descriptions.

Table 1 Description of Power-Swing Blocking Elements

Element Name	Description
SSD SET	Swing signature detector logic output. A logical 1 output for this element sets PSB.
Start-Zn	Starter zone output. A logical 1 output indicates that Z1 is inside the starter zone.
SLD SET	Slope detection logic output. A logical 1 output for this element sets PSB.
PSB Reset	PSB reset logic output. A logical 1 output for this element resets PSB.
3PF Reset	3-phase fault detection logic output. A logical 1 output for this element temporarily removes PSB blocking.
67QUB	Negative-sequence current-unbalance detection logic output. A logical 1 output for this element blocks the SSD logic and also removes PSB blocking temporarily.
DPSB	Dependable PSB logic output. A logical 1 output for this element also asserts PSB.
PSB	Output of the no-setting power-swing blocking function.

From the element output plot, we see that the slope-detector logic asserts the PSB shortly after the three-phase fault is removed and the system goes into OOS. Because the slope detector asserts PSB before the most overreaching distance zone picks up and blocks the distance elements, the

SSD logic does not operate in this example. When the second three-phase fault evolves, the three-phase fault detector operates, removes the power-swing blocking, and allows the distance element to trip on the fault. Notice that 67QUB tends to pick up in current minimums during an OOS condition and temporarily removes the power-swing blocking. These inadvertent pickups are harmless to the power-swing blocking function because the impedance is far away from the distance protection region.

Example 2: OOS With Different Prefault Loads

This example illustrates a system situation that presents a great difficulty to the power-swing blocking function, especially to the conventional PSB function using blinders. When a system is subjected to a three-phase fault, the balance between the mechanical and electrical powers is upset. Synchronous machines start to accelerate. If the system is unstable according to the equal area criterion, the machine angle may be already large at the time the fault clears. Reflected on the impedance plane, the impedance exposed to distance elements may reside inside a protection region when the fault clears and starts to swing from that point. This scenario leaves no time for the conventional PSB logic to react, and, therefore, the distance elements may trip instantaneously after the initial external three-phase fault. With the same system stability margin and a three-phase fault with the same duration and location, a heavier prefault load results in a larger machine angle at the time the fault clears.

Three cases are generated on a simple two-source parallel-line 500 kV system from an EMTF simulation. These cases have prefault load levels of 40 degrees, 55 degrees, and 65 degrees, respectively, but otherwise are the same. A transient three-phase fault is applied initially behind the relay location at 0.55 seconds with a duration of 0.2 seconds. The system begins to swing immediately after fault application.

Figure 26 shows the voltages for these three cases. We can observe that the voltage magnitude at the time of the fault clearance becomes smaller as the prefault load increases. For the 65-degree load, the voltage is almost at its minimum when the fault clears. That means the machine angle almost reaches 180 degrees. This can also be seen in Figure 27, where the Z1 OOS trajectory almost starts at the line angle for the 65-degree load after the three-phase fault clears. Figure 26 shows that, for a lighter load, Z1 starts farther away from the line angle when the fault clears.

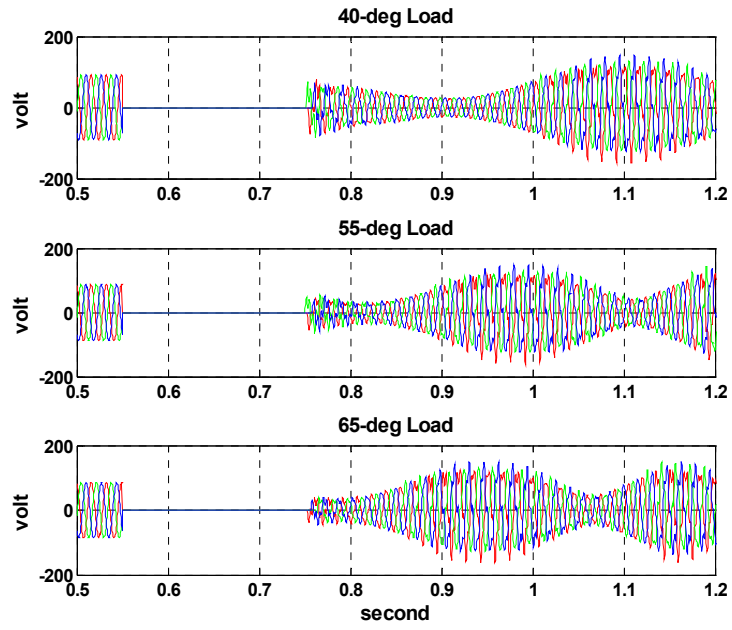

Figure 26 Voltages of Example 2 With Different Loads

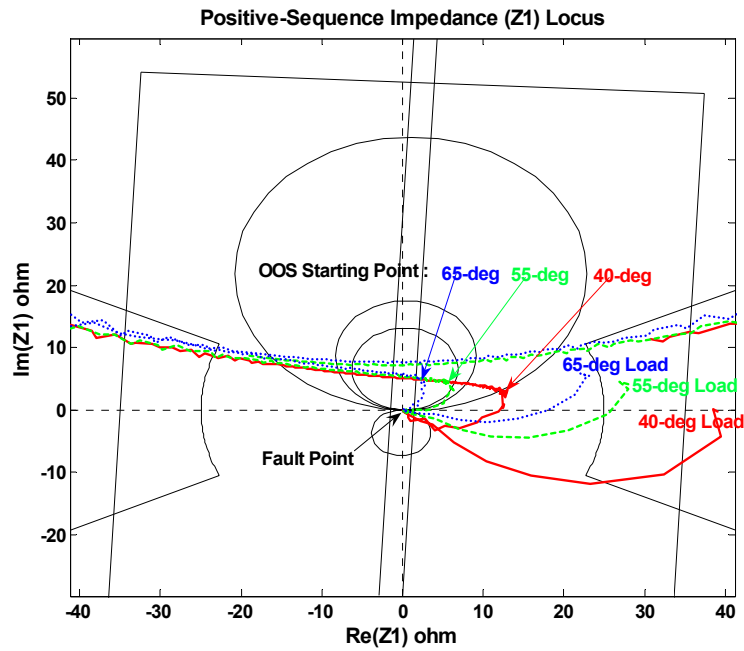

Figure 27 Impedance Trajectories of Example 2 With Different Loads

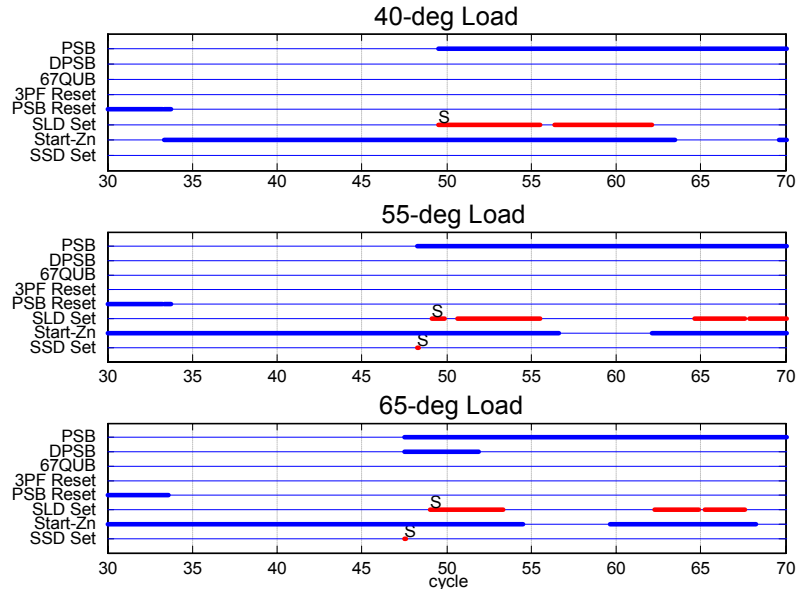

Figure 28 PSB Protection Elements for Example 2 With Different Loads

Figure 28 shows the PSB protection element outputs of these three cases. The PSB reset logic yields a logical 1 output at the beginning during normal system operation. For heavier loading cases of 55 degrees and 65 degrees, the starter zone picks up after the beginning of the event. Unlike the conventional blinder schemes for PSB, the starter zone can pick up under a load without impact on the new swing-detection function.

For the 40-degree load case, we see from Figure 27 that Z1 exits the protection region after the fault clears. In this situation, the slope detector has enough time to detect the swing condition before the most overreaching zone to be blocked, Zone 2 in these cases, picks up. The upper plot of Figure 28 shows that the slope detector output picks up and sets the PSB at about cycle 49.

For the 55-degree load case, Figure 27 indicates that the swing starts at a point very close to the Zone 2 protection characteristic. The Zone 2 distance element picks up shortly after the reverse fault clears. For this case, the slope detector is still qualifying the rate change of the SCV when the Zone 2 element picks up. However, at the rising edge of the Zone 2 pickup, the swing-signature detector verifies the swing condition and asserts PSB as shown in the middle plot of Figure 28.

For the 65-degree load case, Figure 27 shows that the swing starts inside the Zone 1 protection region. Both Zone 2 and Zone 1 distance elements pick up right after the reverse fault clears. There is insufficient time for the slope detector to detect the swing condition. However, as shown in the bottom plot of Figure 28, both the swing-signature detector and the dependable PSB logic detect the swing condition at the rising edge of the Zone 2 element and assert PSB.

CONCLUSION

When a power system loses its stability and goes into an out-of-step condition, the power system should be separated at a few strategic locations to keep subsystems operating at a close balance between generations and loads. The out-of-step tripping function is used for the purpose of separation. At all other locations, the power-swing blocking function is necessary to prevent distance elements from tripping during power system swings.

The conventional PSB function based on blinder schemes is one of the most difficult functions to set. Extensive system stability studies and detailed source information are necessary in setting this function. In modern complex interconnected systems, it is a challenge to get equivalent source impedance. The source impedance is also changing constantly. Because of much work involved in setting the conventional PSB function, it is often left out and not used even if modern microprocessor distance relays provide this function.

This paper describes a PSB function that is based on the swing-center voltage. Unlike other electrical quantities such as resistance and real power, the swing-center voltage does not depend on line and system-source impedances and other system parameters. The swing-center voltage is bounded between zero to one per unit of the system voltage.

The new PSB function the paper describes needs no user settings other than enabling or disabling the function. No system stability studies and source impedance are necessary for the PSB function. The patent-pending PSB function combines the swing-signature detection, the slope detection, and the dependable PSB function to provide reliable power-swing detection under various system situations. The function also fulfills all demanding requirements of modern power-swing protection schemes. These include detecting faults during power-swing blocking, detecting evolving three-phase faults, detecting power swings during pole-open conditions, and detecting faults during pole-open power-swing blocking.

The PSB function has been tested under a relay model environment with data from different EMTP simulations and with some field disturbance data. It has been verified that the PSB function based on the swing-center voltage successfully detects stable power swings and system out-of-step conditions over a wide range of slip frequencies without any user settings.

Through use of the output of the robust PSB function, an OST function could be implemented to track the measured impedance trajectory across the complex impedance plane and to issue a TOWO at a specified phase angle difference between sources. Setting complexities and the need to perform stability studies of the OST function for a TOWO application can be eliminated.

REFERENCES

- [1] D. Hou, S. Chen, and S. Turner, "SEL-321-5 Relay Out-of-Step Logic," Schweitzer Engineering Laboratories, Inc. Application Guide AG97-13, July 23, 1997.
- [2] F. Ilar, "Innovations in the Detection of Power Swings in Electrical Networks," Brown Boveri Publication CH-ES 35-30.10E, 1997.
- [3] V. Centeno, J. De La Ree, A. G. Phadke, G. Michel, and R. Burnett, "Adaptive Out-of-Step Relaying Using Phasor Measurement Techniques," *IEEE Computer Applications in Power*, vol. 6, no. 4, p. 12–17, October 1993.
- [4] O. Faucon and L. Dousset, "Coordinated Defense Plan Protects Against Transient Instabilities," *IEEE Computer Applications in Power*, vol. 10, no. 3, p. 22–26, July 1997.
- [5] J. Holbach, "New Out-of-Step Blocking Algorithm for Detecting Fast Power Swing Frequencies," *Proc. 30th Annual Western Protective Relay Conference*, Spokane, WA, October 21–23, 2003.
- [6] D. Hou, A. Guzman, and J. Roberts, "Innovative Solutions Improve Transmission Line Protection," *Proc. 24th Annual Western Protective Relay Conference*, Spokane, WA, October 21–23, 1997.

- [7] D. Hou and J. Mooney, "Protective Relay Having Dependable Out-of-Step Blocking Capability," SEL patent application.
- [8] E. W. Kimbark, *Power System Stability*, vol. 2, John Wiley and Sons, Inc., New York, 1950.
- [9] J. Machowski and D. Nelles, "New Power Swing Blocking Method," *Proc. Sixth International Conference on Developments in Power System Protection* (Conf. Publ. No. 434), pp. 218–221, London, UK, March 1997.
- [10] A. G. Phadke, B. Pickett, M. Adamiak, and M. Begovic, "Synchronized Sampling and Phasor Measurements for Relaying and Control," *IEEE Transactions on Power Delivery*, vol. 9, no. 1, p. 442–452, January 1994.
- [11] E. O. Schweitzer III, G. Benmouyal, and A. Guzmán, "Synchronized Phasor Measurement in Protective Relays for Protection, Control, and Analysis of Electrical Power Systems," *Proc. 29th Annual Western Protective Relay Conference*, Spokane, WA, October 22–24, 2002.
- [12] D. Tziouvaras and D. Hou, "Out-of-Step Protection Fundamentals and Advancements," *Proc. 30th Annual Western Protective Relay Conference*, Spokane, WA, October 21–23, 2003.
- [13] "Wide Area Protection and Emergency Control," IEEE Power System Relaying Committee, 2002 Report, available at <http://www.pes-psrc.org/>.

APPENDIX

In this appendix, we derive an equation that describes the swing-center voltage for a two-source system shown in Figure 29. Z_{1S} , Z_{1L} , and Z_{1R} are the local source, line, and remote source impedance, respectively.

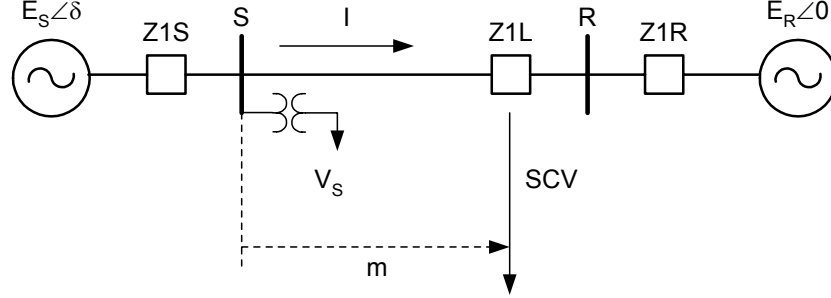

Figure 29 A Two-Source Power System

When the machine angle of two sources in Figure 29 swings apart to 180 degrees, there is a point on the system where the voltage will be zero. The voltage at this location is defined as the swing-center voltage.

Let the local and remote emfs be,

$$e_S(t) = \sqrt{2}E_S \sin(\omega t + \delta(t)) \quad (A1)$$

$$e_R(t) = \sqrt{2}E_R \sin(\omega t) \quad (A2)$$

Assume the swing-center voltage location is m distance from the local measurement terminal, S. The swing-center voltage takes the following value when the local source acts alone,

$$u_{C|S}(t) = \frac{Z_{1R} + (1-m)Z_{1L}}{Z_{1S} + Z_{1L} + Z_{1R}} \sqrt{2}E_S \sin(\omega t + \delta(t)) \quad (A3)$$

When the remote source acts alone, the swing-center voltage equals,

$$u_{C|R}(t) = \frac{Z_{1R} + (1-m)Z_{1L}}{Z_{1S} + Z_{1L} + Z_{1R}} \sqrt{2}E_S \sin(\omega t + \delta(t)) \quad (A4)$$

By the definition of the swing-center voltage, we have the following equation,

$$u_{C|S}(t) = \frac{Z_{1R} + (1-m)Z_{1L}}{Z_{1S} + Z_{1L} + Z_{1R}} \sqrt{2}E_S \sin(\omega t + \delta(t)) \quad (A5)$$

The location of the swing center, m , can be solved from the above equation for this simple system. Through use of the superposition principle, we can express the swing-center voltage as a linear combination of voltage drops acting by two sources individually. The swing-center voltage therefore equals the following:

$$SCV(t) = u_{C|S} + u_{C|R} = \sqrt{2}U_{C0} [\sin(\omega t + \delta(t)) + \sin(\omega t)] \quad (A6)$$

Where U_{C0} is the quantity given in equation (A5). Using the trigonometric equality, we obtain the following:

$$\begin{aligned}
& \sin A + \sin B \\
&= 2 \sin \frac{A}{2} \cos \frac{A}{2} + 2 \sin \frac{B}{2} \cos \frac{B}{2} \\
&= 2 \left(\sin^2 \frac{B}{2} + \cos^2 \frac{B}{2} \right) \sin \frac{A}{2} \cos \frac{A}{2} + 2 \left(\sin^2 \frac{A}{2} + \cos^2 \frac{A}{2} \right) \sin \frac{B}{2} \cos \frac{B}{2} \\
&= 2 \left[\sin \frac{A}{2} \cos \frac{B}{2} + \sin \frac{B}{2} \cos \frac{A}{2} \right] \cdot \left[\cos \frac{A}{2} \cos \frac{B}{2} + \sin \frac{A}{2} \sin \frac{B}{2} \right] \\
&= 2 \sin \left(\frac{A+B}{2} \right) \cdot \cos \left(\frac{A-B}{2} \right)
\end{aligned}$$

The swing-center voltage can be re-written as,

$$SCV(t) = 2\sqrt{2}U_{C0} \sin\left(\omega t + \frac{\delta(t)}{2}\right) \cdot \cos\left(\frac{\delta(t)}{2}\right) \quad (A7)$$

With the assumption that both sources have an equal magnitude, E , it can be verified easily that U_{C0} equals $\frac{E}{2}$; and equation (A7) becomes the following:

$$SCV(t) = \sqrt{2}E \sin\left(\omega t + \frac{\delta(t)}{2}\right) \cdot \cos\left(\frac{\delta(t)}{2}\right) \quad (A8)$$

BIOGRAPHIES

Gabriel Benmouyal, P.E. received his B.A.Sc. in Electrical Engineering and his M.A.Sc. in Control Engineering from Ecole Polytechnique, Université de Montréal, Canada in 1968 and 1970, respectively. In 1969, he joined Hydro-Québec as an Instrumentation and Control Specialist. He worked on different projects in the field of substation control systems and dispatching centers. In 1978, he joined IREQ, where his main field of activity was the application of microprocessors and digital techniques to substation and generating-station control and protection systems. In 1997, he joined Schweitzer Engineering Laboratories, Inc., in the position of Principal Research Engineer. He is a registered professional engineer in the Province of Québec, is an IEEE Senior Member, and has served on the Power System Relaying Committee since May 1989. He holds over six patents and is the author or co-author of several papers in the field of signal processing and power networks protection.

Daqing Hou received B.S. and M.S. degrees in Electrical Engineering at the Northeast University, China, in 1981 and 1984, respectively. He received his Ph.D. in Electrical and Computer Engineering at Washington State University in 1991. Since 1990, he has been with Schweitzer Engineering Laboratories, Inc., Pullman, Washington, USA, where he has held numerous positions including development engineer, application engineer, and R&D manager. He is currently a principal research engineer. His work includes system modeling, simulation, and

signal processing for power systems and digital protective relays. His research interests include multivariable linear systems, system identification, and signal processing. He holds multiple patents and has authored or co-authored many technical papers. He is a Senior Member of IEEE.

Demetrios A. Tziouvaras has a B.S. and M.S. in Electrical Engineering from the University of New Mexico and Santa Clara University, respectively. He is an IEEE Senior member and a member of the Power Engineering Society, the Power System Relaying Committee, and CIGRE. He joined Schweitzer Engineering Laboratories, Inc. in 1998 and currently holds the position of Senior Research Engineer. From 1980 until 1998, he was with Pacific Gas and Electric, where he held various protection engineering positions including Principal Protection Engineer responsible for protection design standards, new technologies, and substation automation. He holds three patents associated with power system protection using microprocessor technology and is the author or co-author of more than 20 IEEE and Protective Relay Conference papers. Currently, he is the convener of CIGRE WG B5-15 on “Modern Distance Protection Functions and Applications” and a member of several IEEE PSRC and CIGRE working groups.

20041130
TP6172-01