

PIER Demand Response Research Center

IEEE Summer Banquet

August 18, 2004

Mary Ann Piette

Sponsored by the California Energy Commission



LAWRENCE BERKELEY NATIONAL LABORATORY

Presentation Overview



- Demand Response in California
- Demand Response Research Center
- Current Projects
- Summary & Next Steps

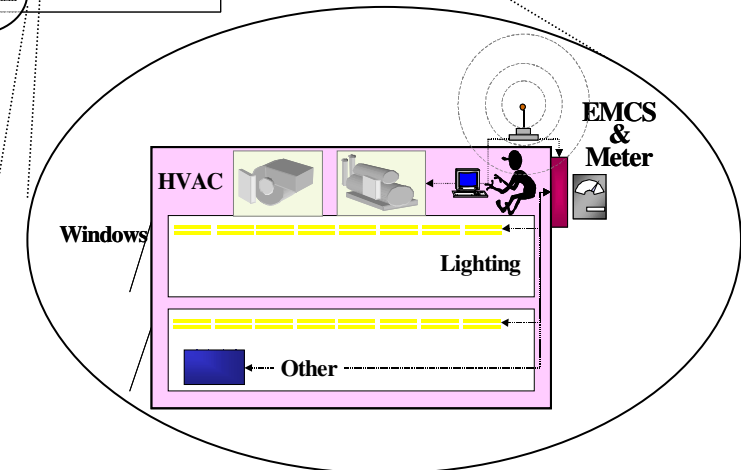
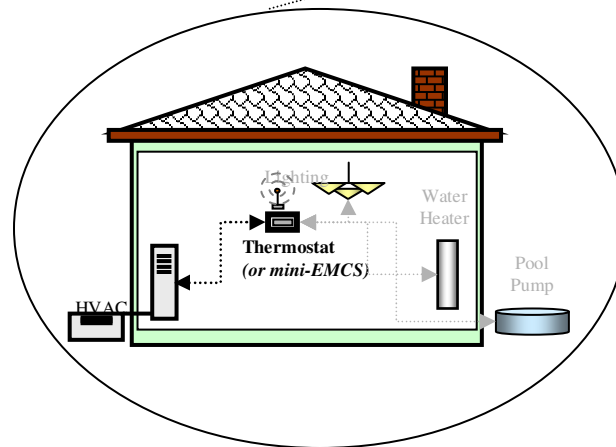
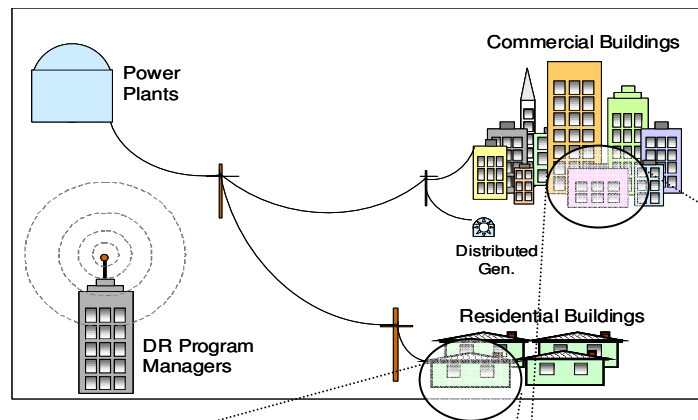

Demand Response in California



- **Motivations for DR**
 - Improve grid reliability, flatten load shape, lower costs
- **Current Programs & Policies**
 - Energy Action Plan & Order Institute Rulemaking
 - Goal of 5% peak reduction by 2007 with price response
 - Residential - Statewide Pricing Pilot
 - Commercial & Industrial - Critical Peak Pricing, Demand Bidding

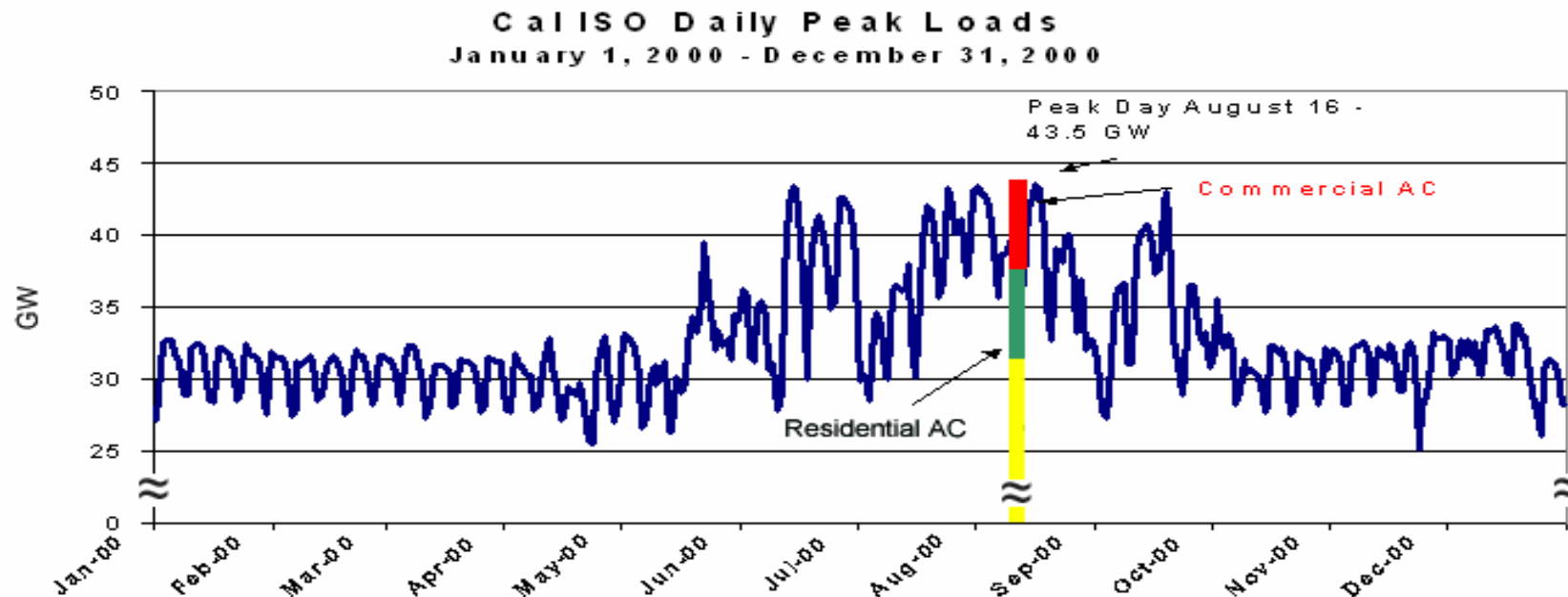

Demand Response Programs & Tariffs



- **Load response for reliability purposes**
 - direct load control, partial or curtailable load reductions
 - complete load interruptions
- **Price response by end-use customers**
 - dynamic pricing: real-time pricing (RTP), coincident peak pricing (CPP), time-of-use rates (TOU)
 - demand bidding or buyback programs

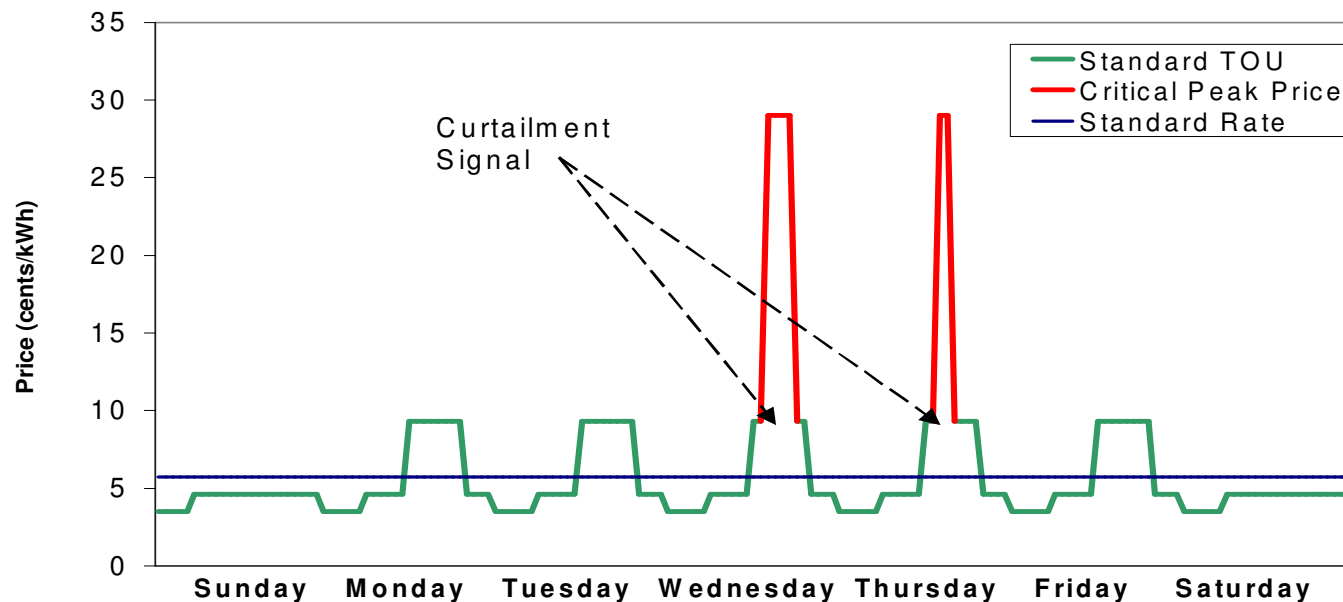

Demand Response Research Center



- **Objective:** to develop, prioritize, conduct, and disseminate multi-institutional research to facilitate DR
- **Scope:** technologies, policies, programs, strategies and practices, emphasizing a market connection
- **Method:** Partners Planning Committee, Annual R&D Plan
- **Stakeholders:**
 - State policy makers
 - Researchers
 - Information & metering system developers
 - Aggregators
 - Program implementers
 - Utilities
 - Industry trade associations
 - Building owners, engineers & operators
 - Building equipment manufacturers
 - Other end-use customers

Project 1 - Evaluation of RTP for Large Users

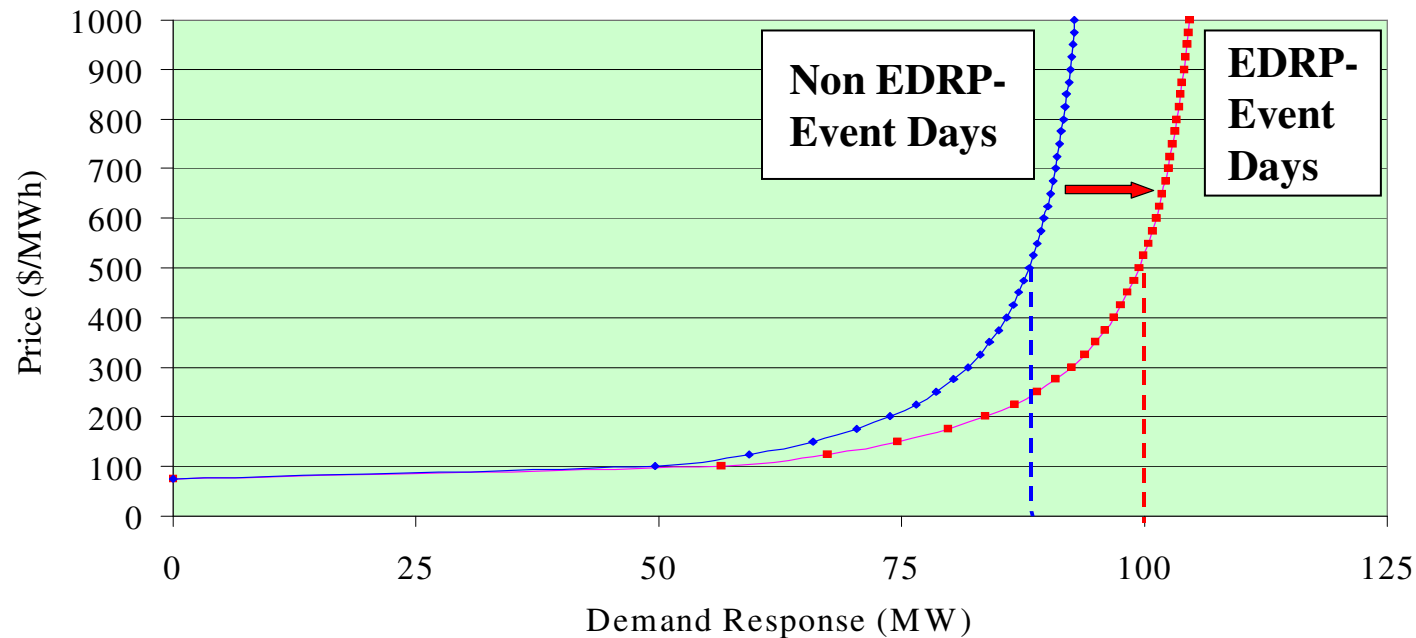

- **Goal** - Understand RTP within portfolio of DR policies & programs
- **Current Work** – Market characterization of NY & US programs
- **Recent Results** – ~100 MW, or 18% of peak from RTP at 50 ¢/kWh
Emergency DR Program provided ~15 MW

Project 2 - Demand Shifting with Thermal Mass



- **Goal** - understand demand shifting with mass & assist in optimal use of new control strategies
- **Current Work** – large & small commercial building field studies & preliminary simulation study
- **Recent Results** –2003 Santa Rosa demo shifted afternoon chiller power (2 W/ft²)



Concrete Floor

Thermal Capacity
~ 3 Watts-Hours/ft³ - F

Project 3 – Automated Demand Response



- **Goal** - support DR through evaluation of automated in controls, communications, & DR strategies in large facilities
- **Current Work** – 2004 study pursuing 20 sites with Energy (EIS) Information Systems and direct link to Energy Management Control System (EMCS)
- **Recent Results** – Fully automated shed in 5 sites in 2003 reduced load by 10%

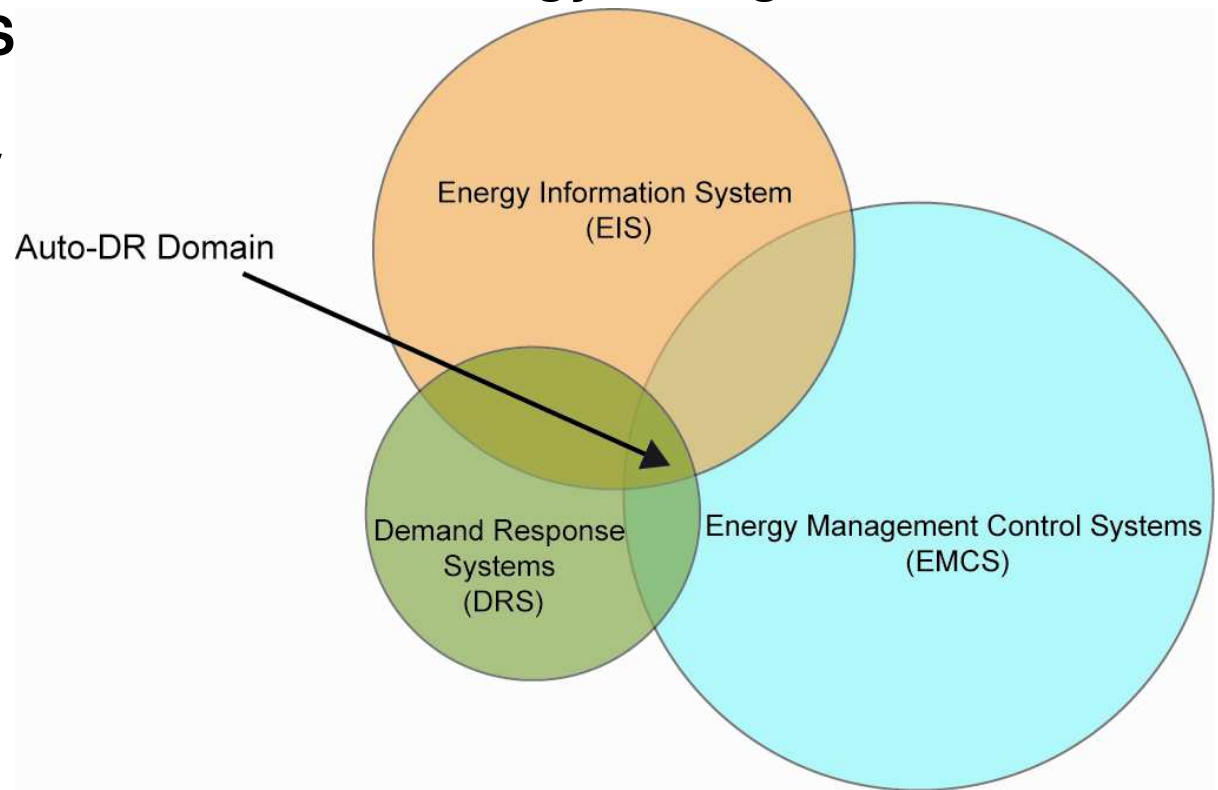

2003 Automated-DR Participants



Albertsons – East 9th St. Oakland

Engagenet

Bank of America – Concord Technology Center

Webgen

General Services Admin - Oakland Fed. Building

BACnet Reader

Roche Palo Alto – Office and Cafeteria

Tridium

Univ. of Calif. Santa Barbara – Library

Itron Silicon Energy

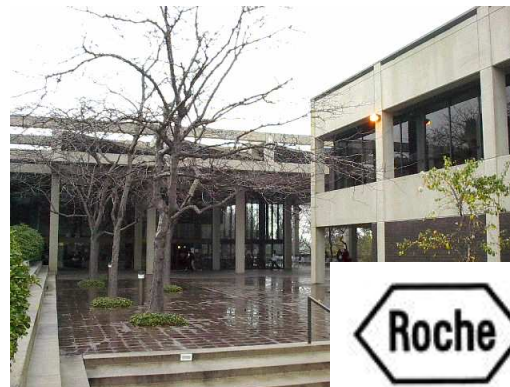
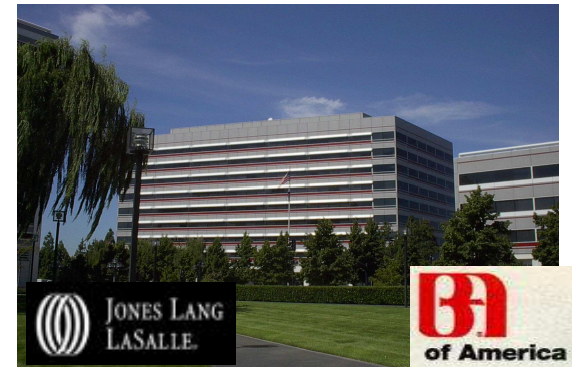

Auto-DR System Communications



1. LBNL defines price schedule
2. Price published on XML server
3. Clients request price every 1-5 minutes & replies to server
4. Business logic determines response
5. EMCS carries out shed

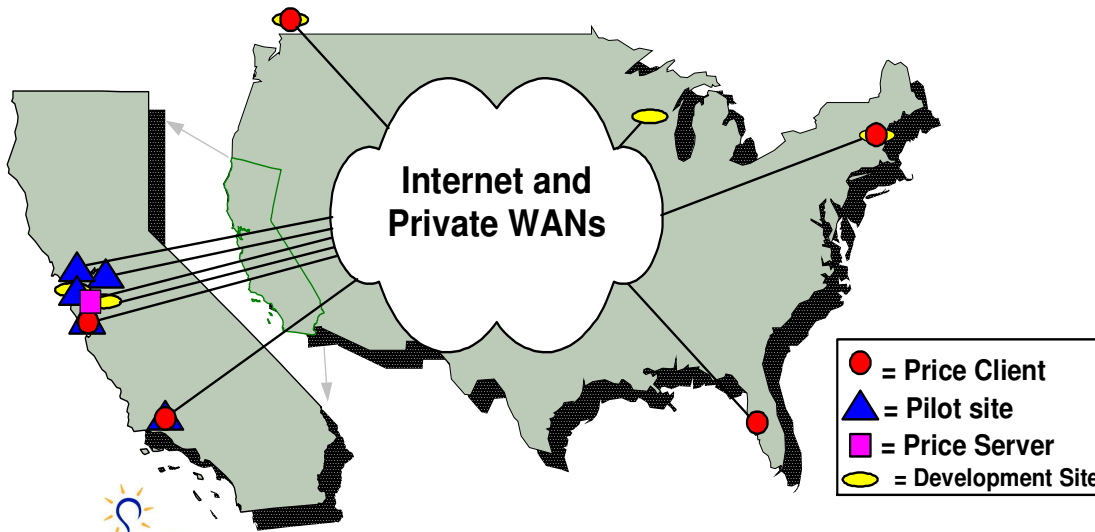
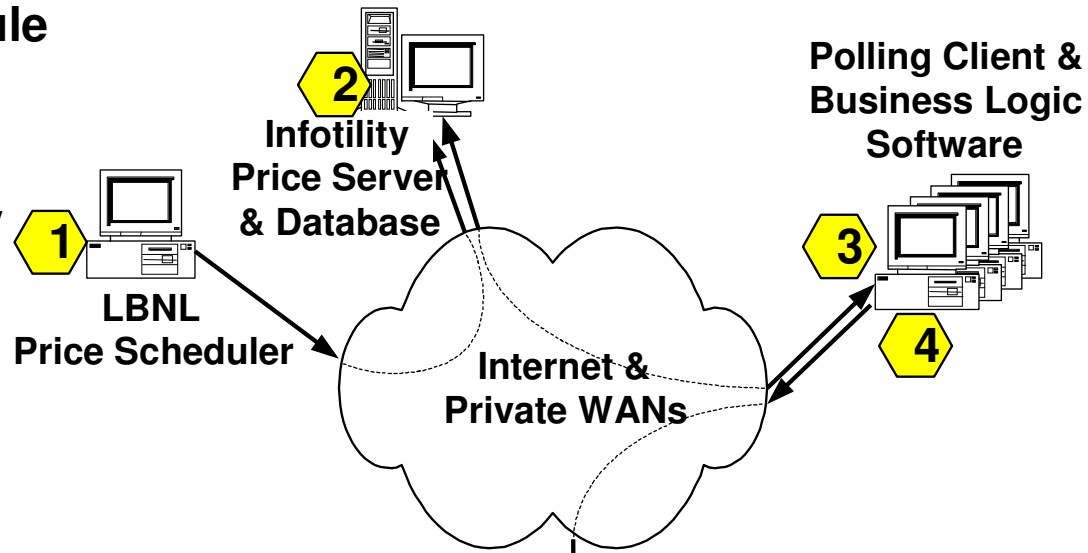

● = Price Client
▲ = Pilot site
■ = Price Server
● = Development Site

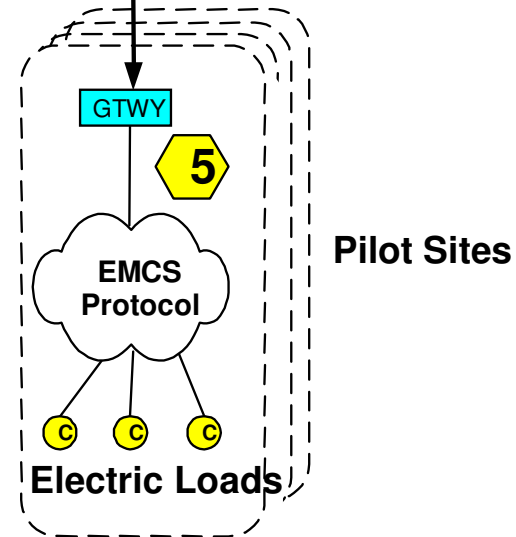

Test Sites - Circa 1999 (1 of 3)

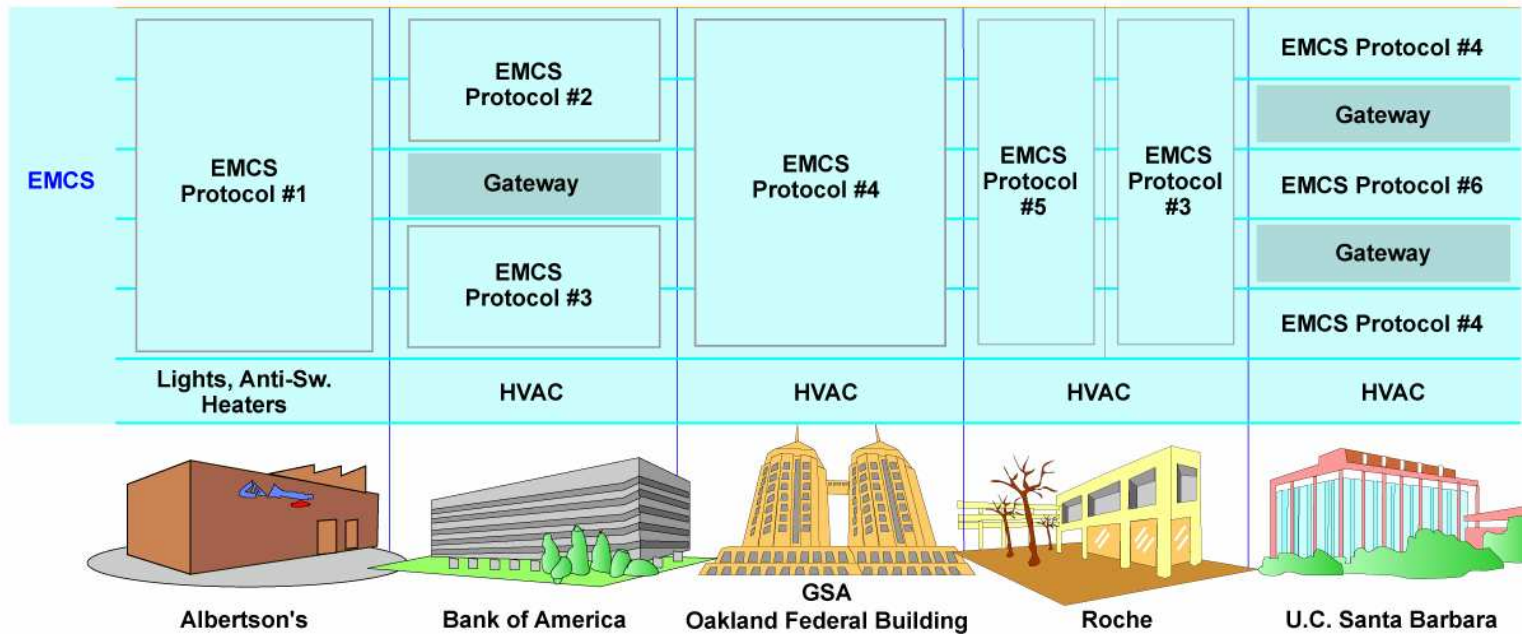

Test Sites - After Energy Crisis (2 of 3)

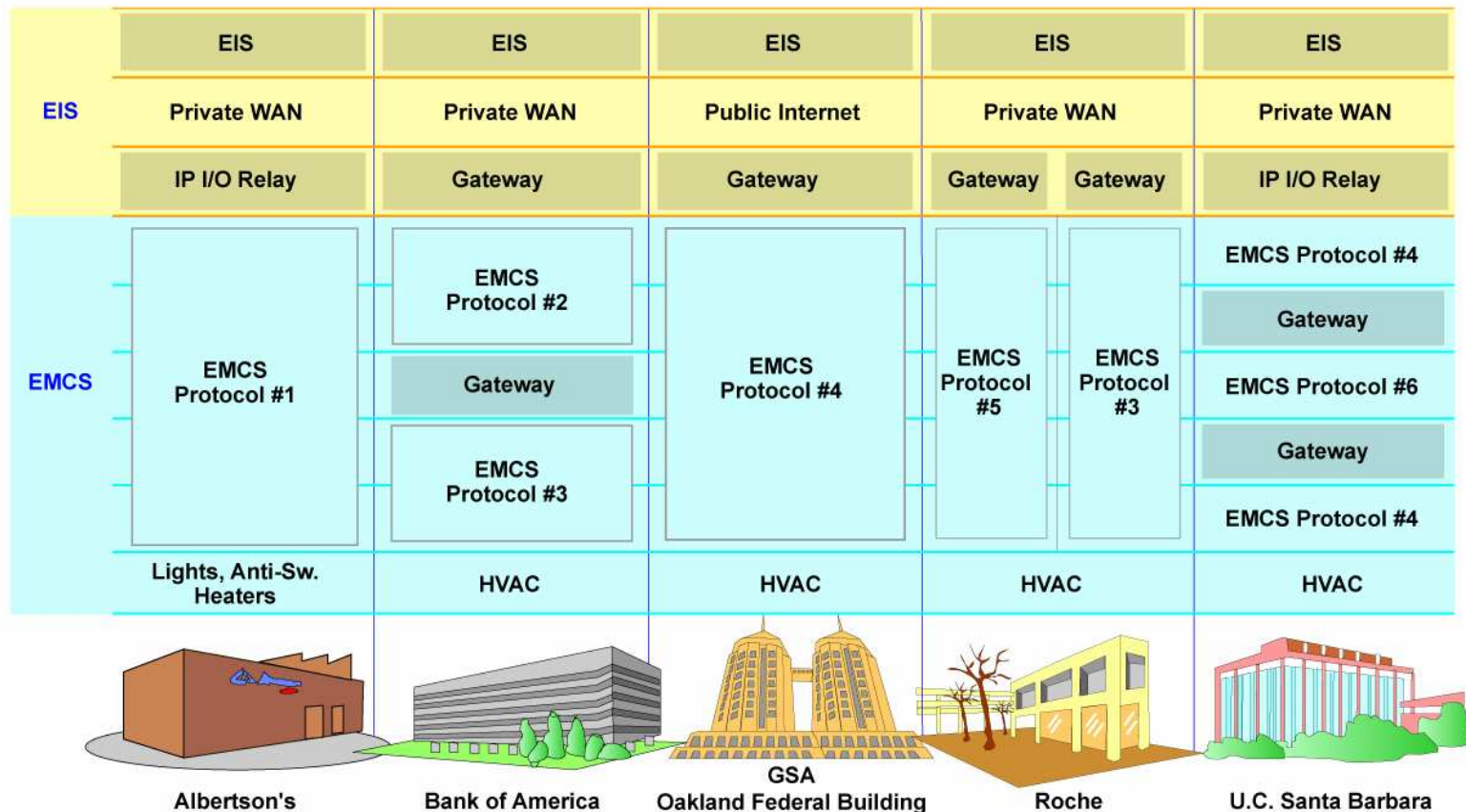

Test Sites –2003 Auto-DR Test (3 of 3)

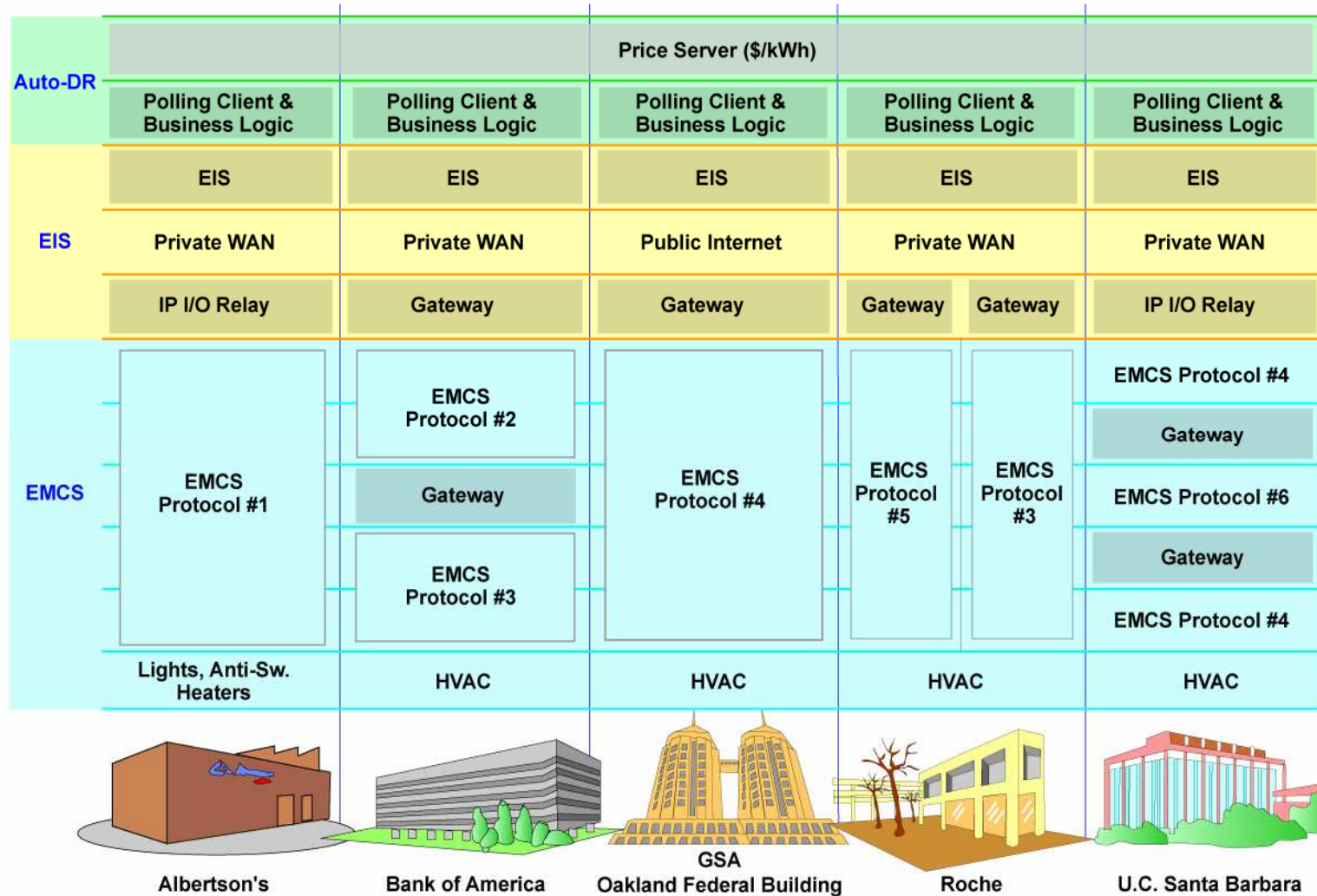

Results - Day-2 Test

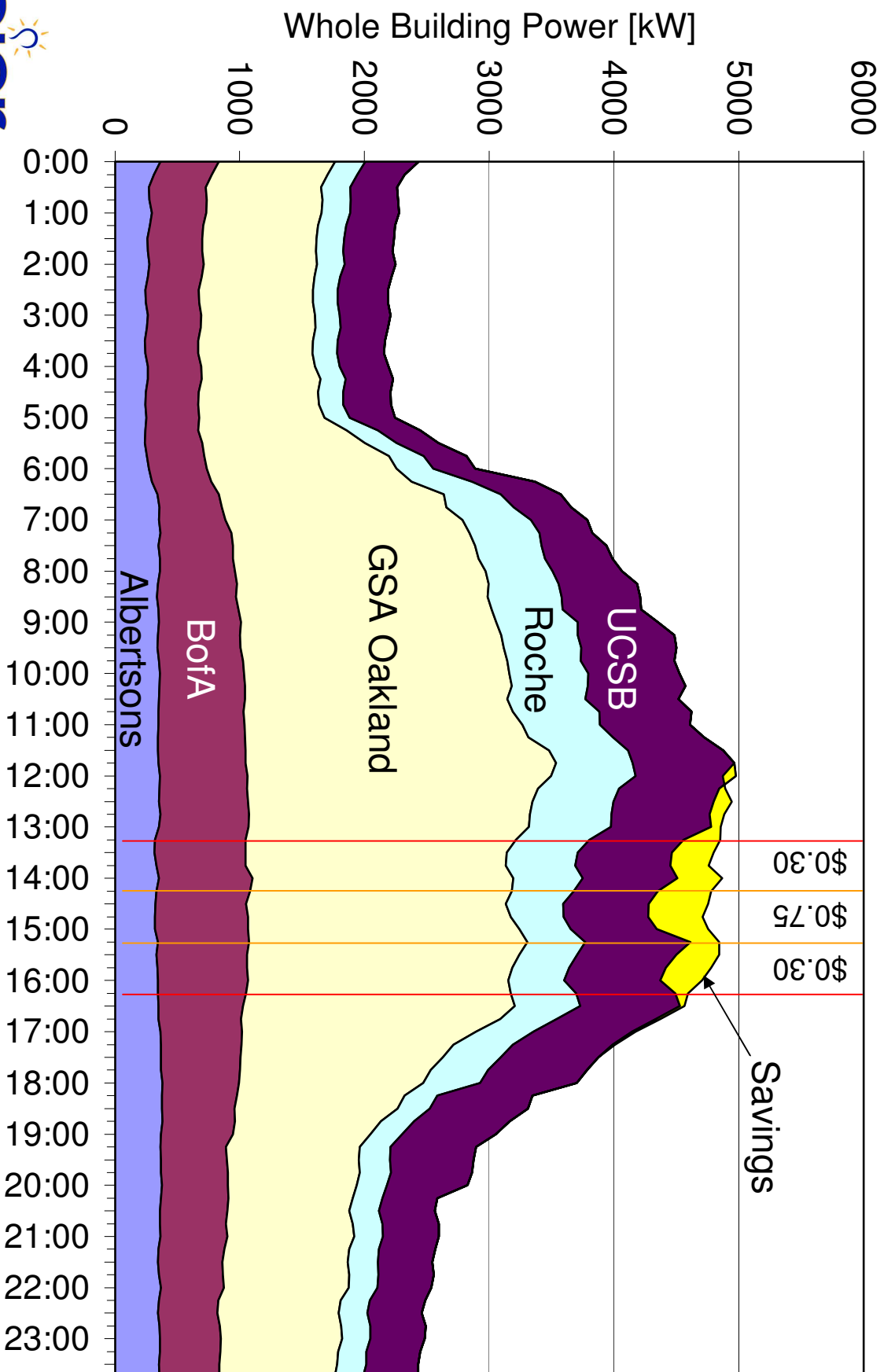

Summary and Next Steps



- **New knowledge needed to develop, operate & evaluate technology & strategies for DR**
- **3 projects underway**
- **Scoping study planned for fall**
 - Build on current CEC R&D
 - Build on California DR activities

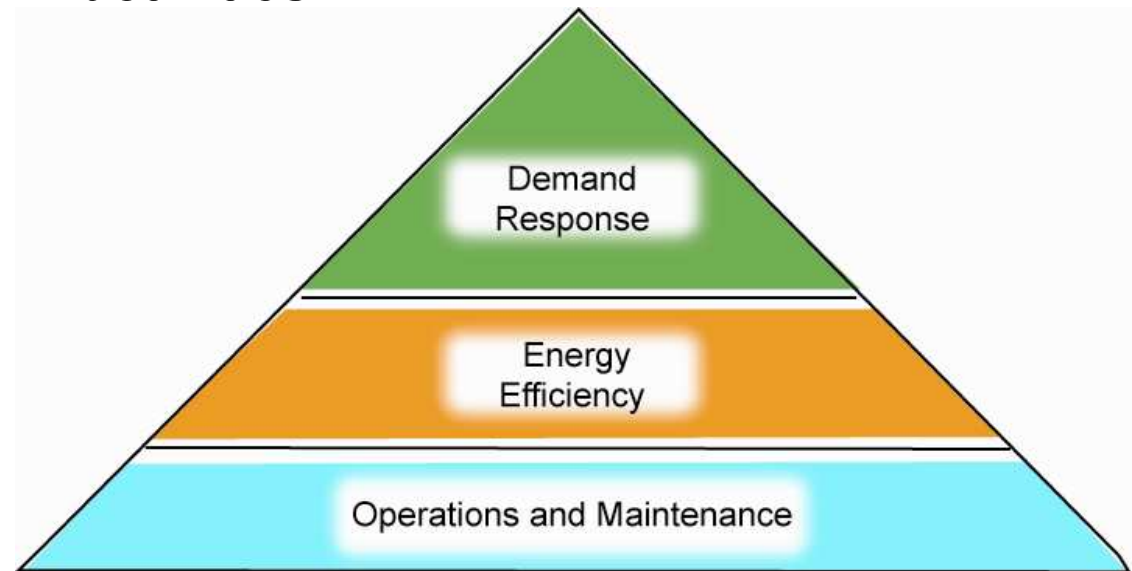

Further Information



- **Contact: Mary Ann Piette, mapiette@lbl.gov, 510 486-6286**
- **Demand Response Research Center**
drrc.lbl.gov
- **Current CEC Demand Response Sites**
 - www.energy.ca.gov/demandresponse
 - Consortium for Electric Reliability Technology Solutions (CERTS)
certs.lbl.gov
 - Center for the Study of Energy Markets (CSEM)
www.ucei.berkeley.edu/power.html
 - Demand Response Enabling Technology Development (DRETD)
ciew.ucop.edu/dretd
- **Buildings Research**
 - **Buildings.lbl.gov/hpcbs/Pubs.html**