



IEEE
COMMUNICATIONS
SOCIETY

Santa Clara Valley Chapter

Vectored DSL

**How Crosstalk Cancellation Leads to
100 Mbps Broadband Access**

George Ginis

September 8th, 2010

Basics of DSL Transmission

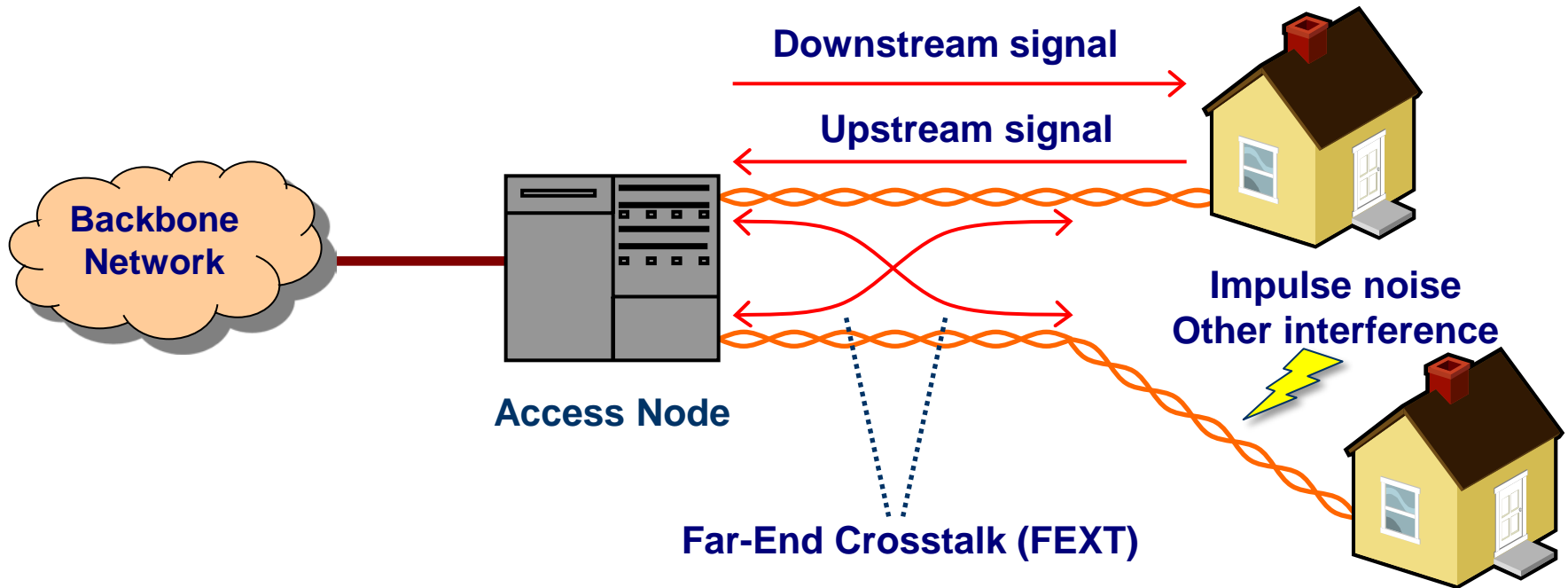

Signal always present on active lines

Uses frequencies between DC and up to 30 MHz

Impulse noise mitigated by FEC/interleaving or retransmission

Frequency division separates downstream from upstream

Crosstalk interference limits transmission data rates

The Crosstalk Problem

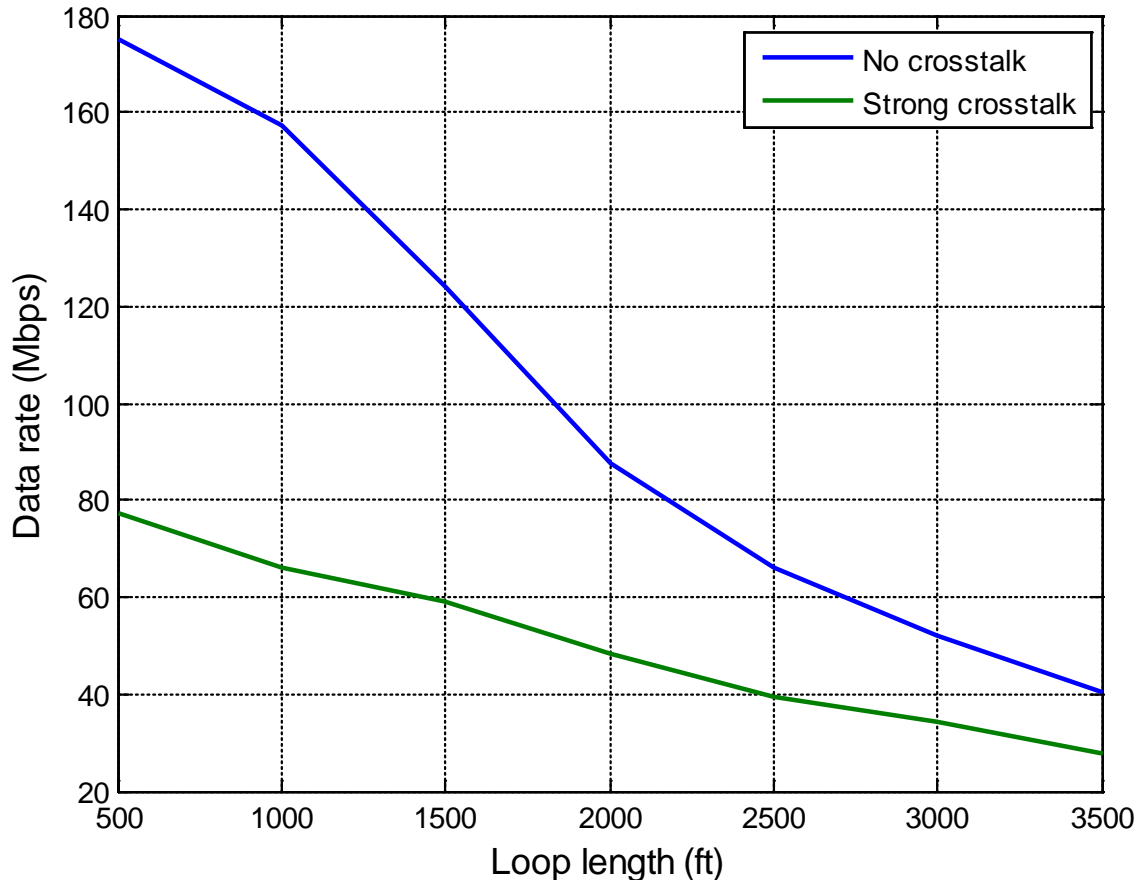

- 25 VDSL2 lines
- Band plan: 998, 17a profile
- Limit PSD mask: D-32
- Gap: 11.6dB
- Bit cap: 15
- Background noise: -140dBm/Hz

Far-End Crosstalk impairs performance in short loops

Downstream Vectoring Concept

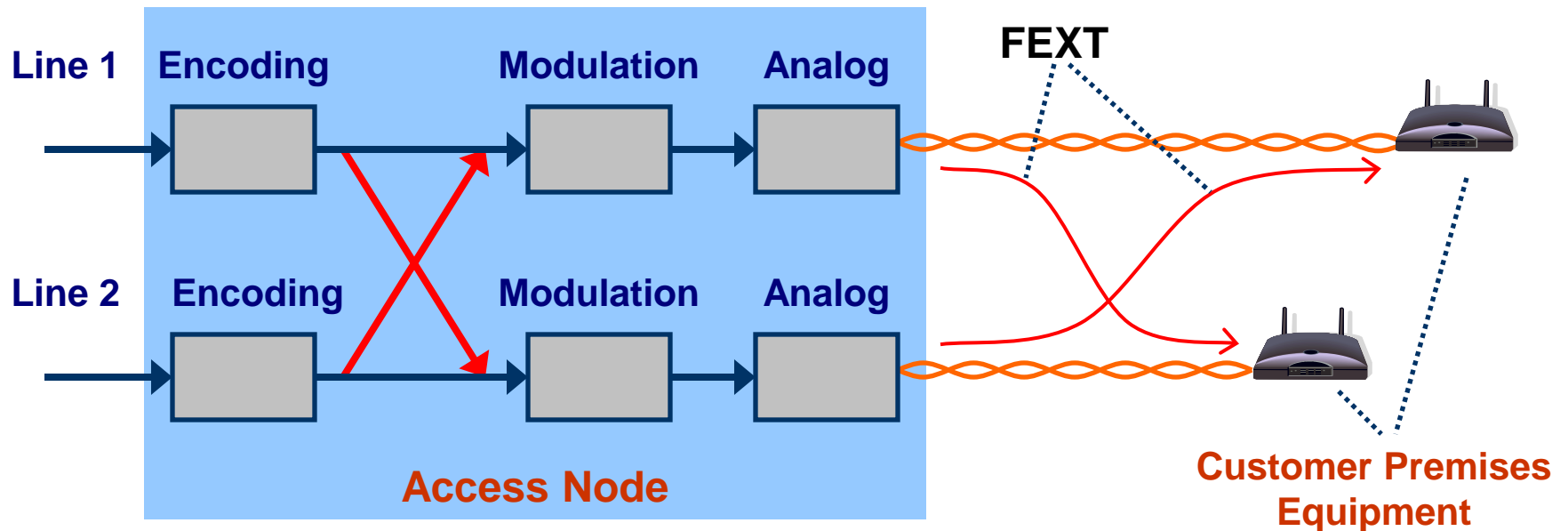

Pre-compensates for FEXT

Downstream received signal is free of crosstalk

Requires joint signal processing by transmitters

Simplification with Discrete Multi-Tone

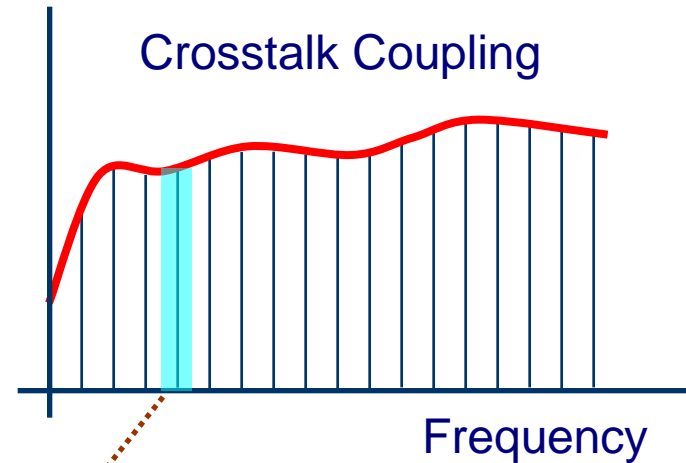
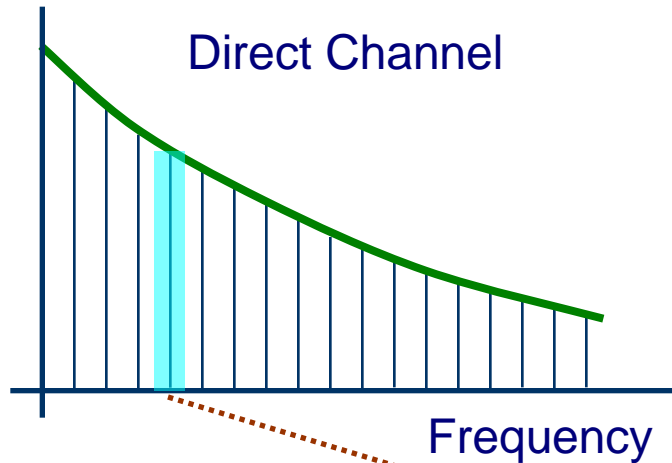

Rx signal of line 1, tone n: $Y_1^{(n)} = H_{11}^{(n)} X_1^{(n)} + H_{12}^{(n)} X_2^{(n)} + N_1^{(n)}$

Rx signal of line 2, tone n: $Y_2^{(n)} = H_{21}^{(n)} X_1^{(n)} + H_{22}^{(n)} X_2^{(n)} + N_2^{(n)}$

Assumes synchronization among lines using “Zippering” technique

Precoding can be applied independently on each tone

Transmitter Architecture

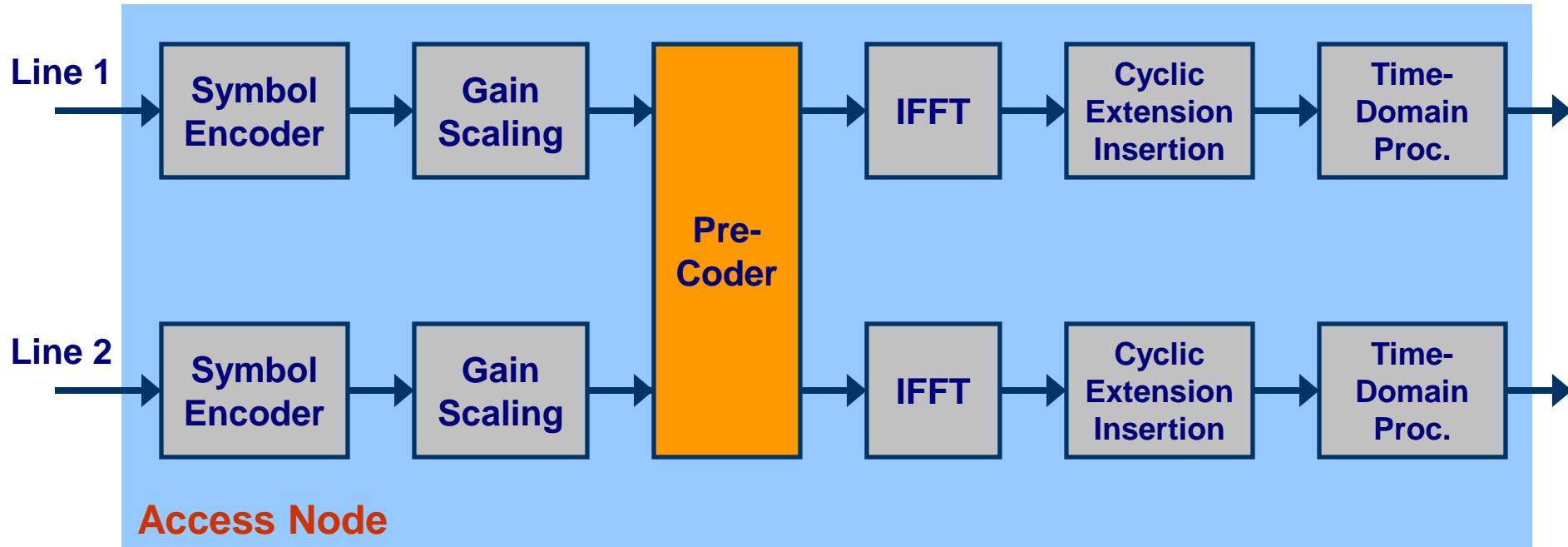

Precoding performed in the frequency domain

Precoding applied independently on each tone

Near-optimality of Linear Precoding

- DSL MIMO channel has special property:
 - “Row-wise diagonal dominance”

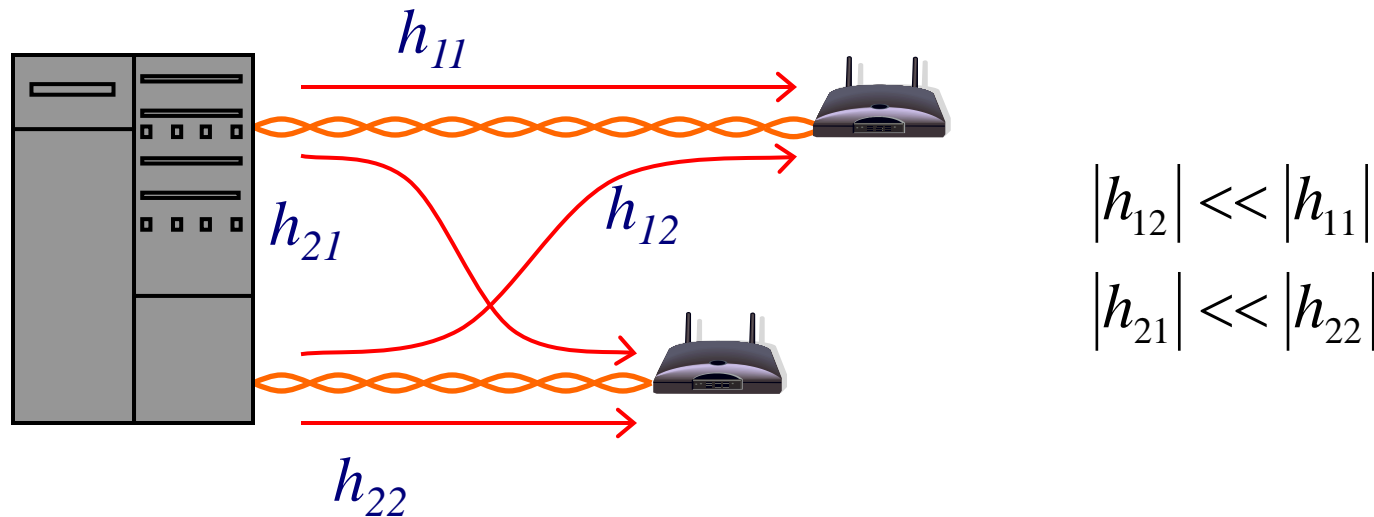

Linear techniques perform near-optimally

Performance Gain from Linear Precoding

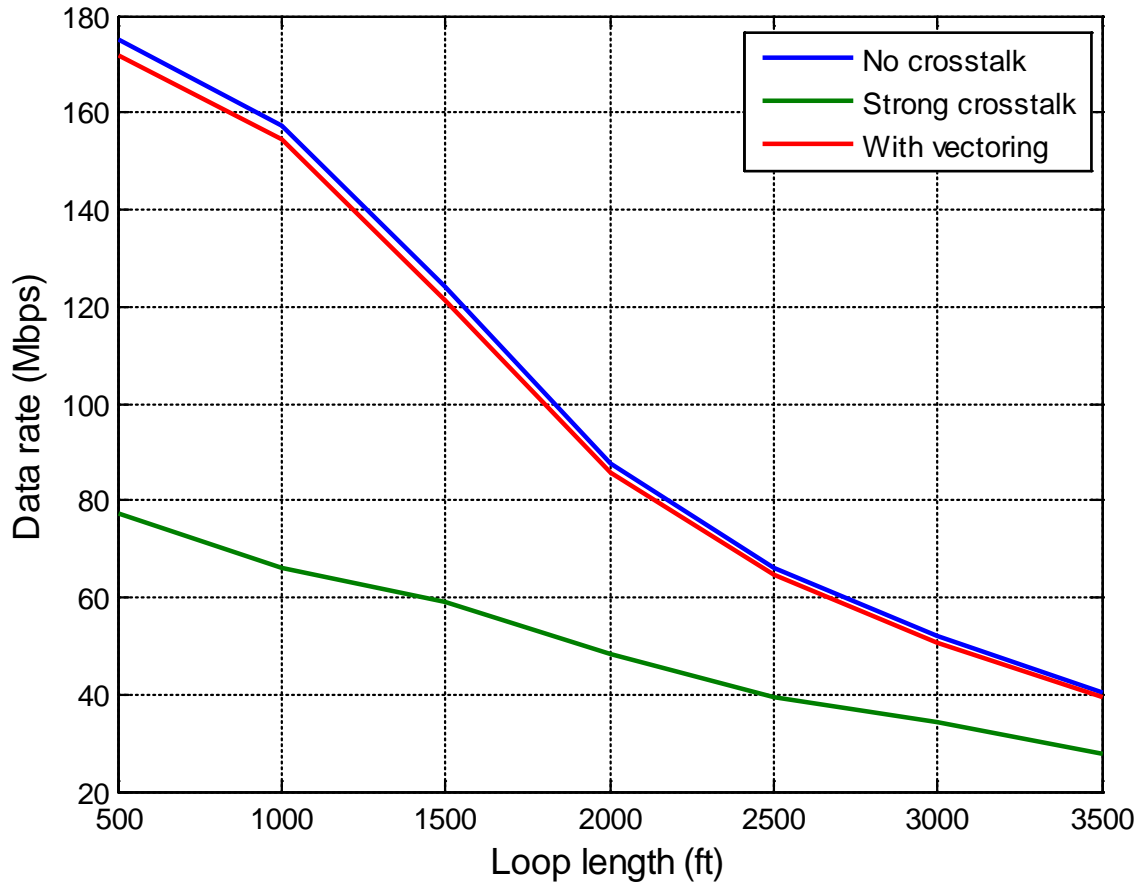

- 25 VDSL2 lines
- Band plan: 998, 17a profile
- Limit PSD mask: D-32
- Gap: 11.6dB
- Bit cap: 15
- Background noise: -140dBm/Hz

Linear precoding achieves near-crosstalk-free performance

Channel Estimation

Transmitter must know MIMO channel

Receivers must feed-back information

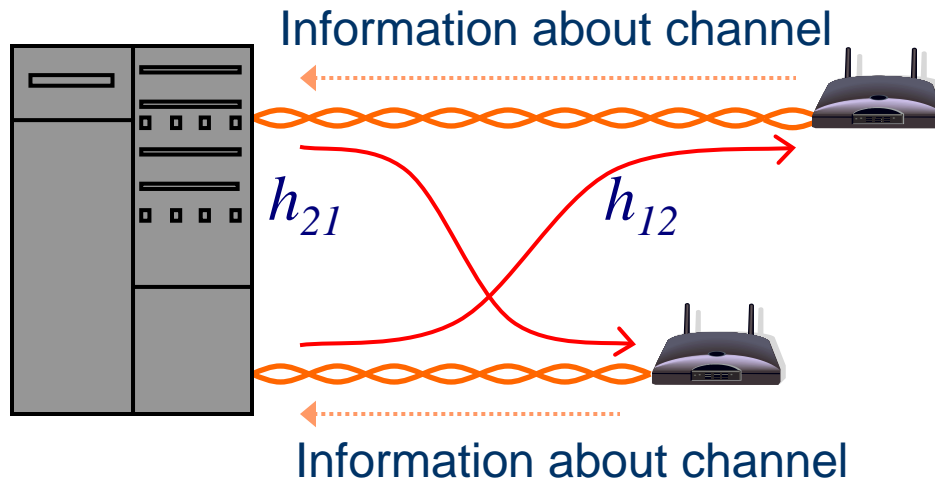

Channel Estimation at the Transmitter

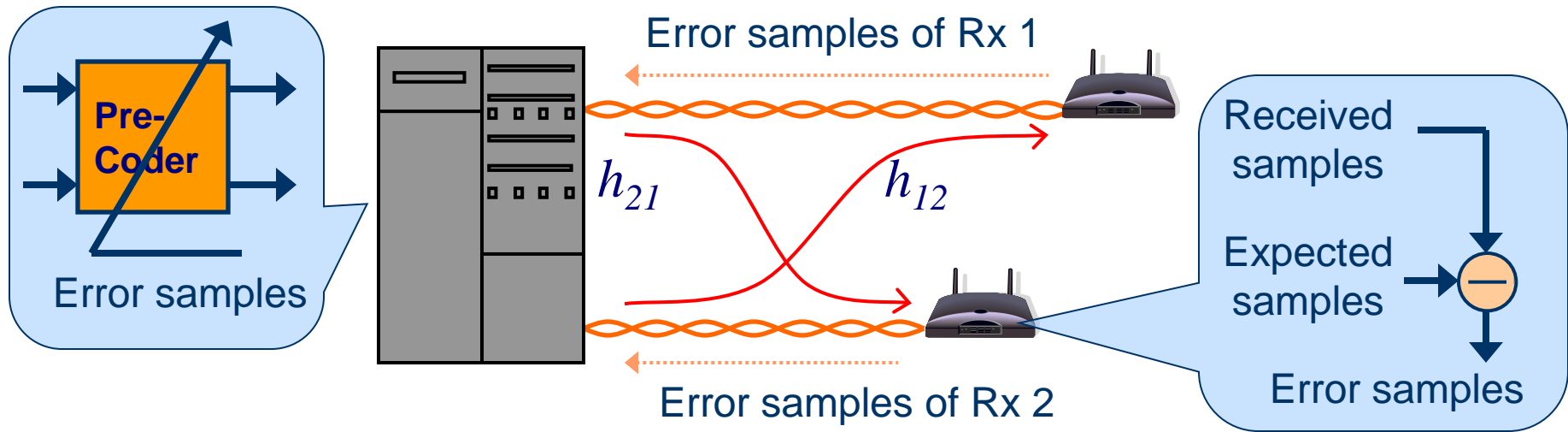

□ **Known-sequence-based estimation at the transmitter:**

- Transmitters periodically send known sequences (“sync” symbols)
- Known sequence sent by each transmitter is unique (e.g. WH codes)
- Receivers compute error samples from “sync” symbols
- Error samples sent to the transmitters
- Transmitters update the pre-coder by correlation of:
 - Received error samples
 - Known sequences

Introduction of New Line

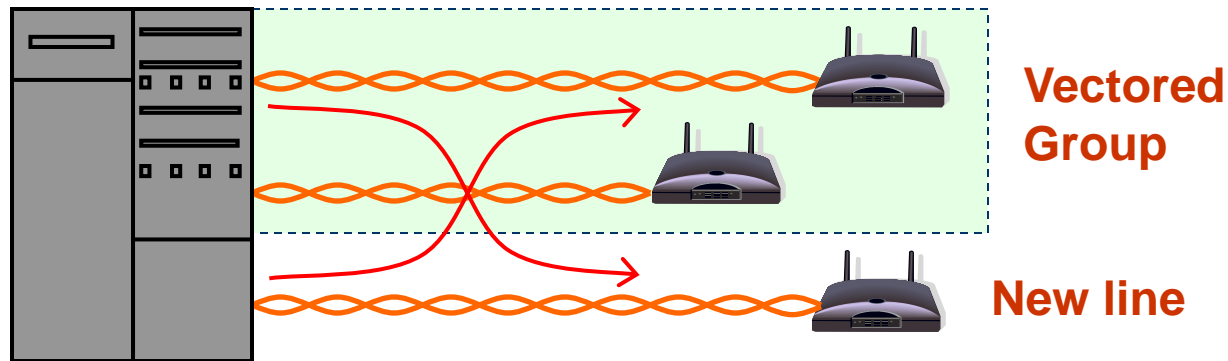

❑ Problems with new line

- Can appear at any time:
 - Service activation
 - Modem re-initialization
- Causes crosstalk to vectored lines
- Is impaired by crosstalk from the vectored lines

❑ New line must join the vectored group

- No disruption of already operating lines

Sync Symbol Transmission for New Line

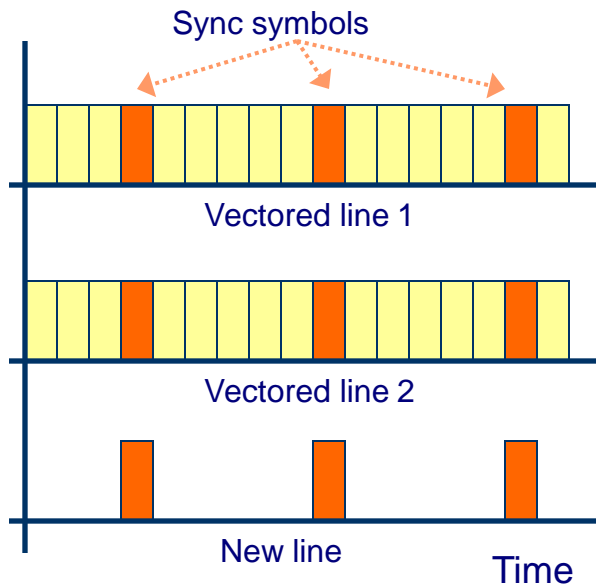
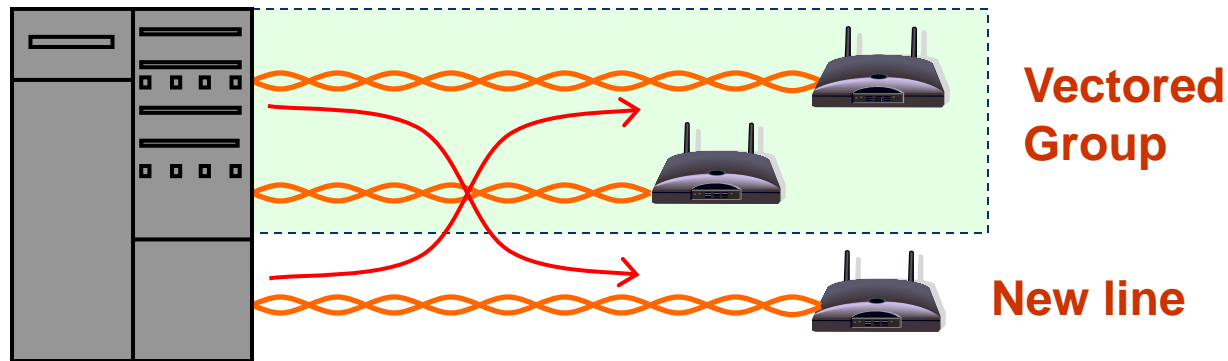

- ❑ **Transmit only sync symbols**
 - No impact on data symbols
- ❑ **Learn crosstalk coupling**
 - From vectored lines
 - Into vectored lines
- ❑ **Initialize pre-coder**
- ❑ **Start normal transmission**



Management of Vectored DSL

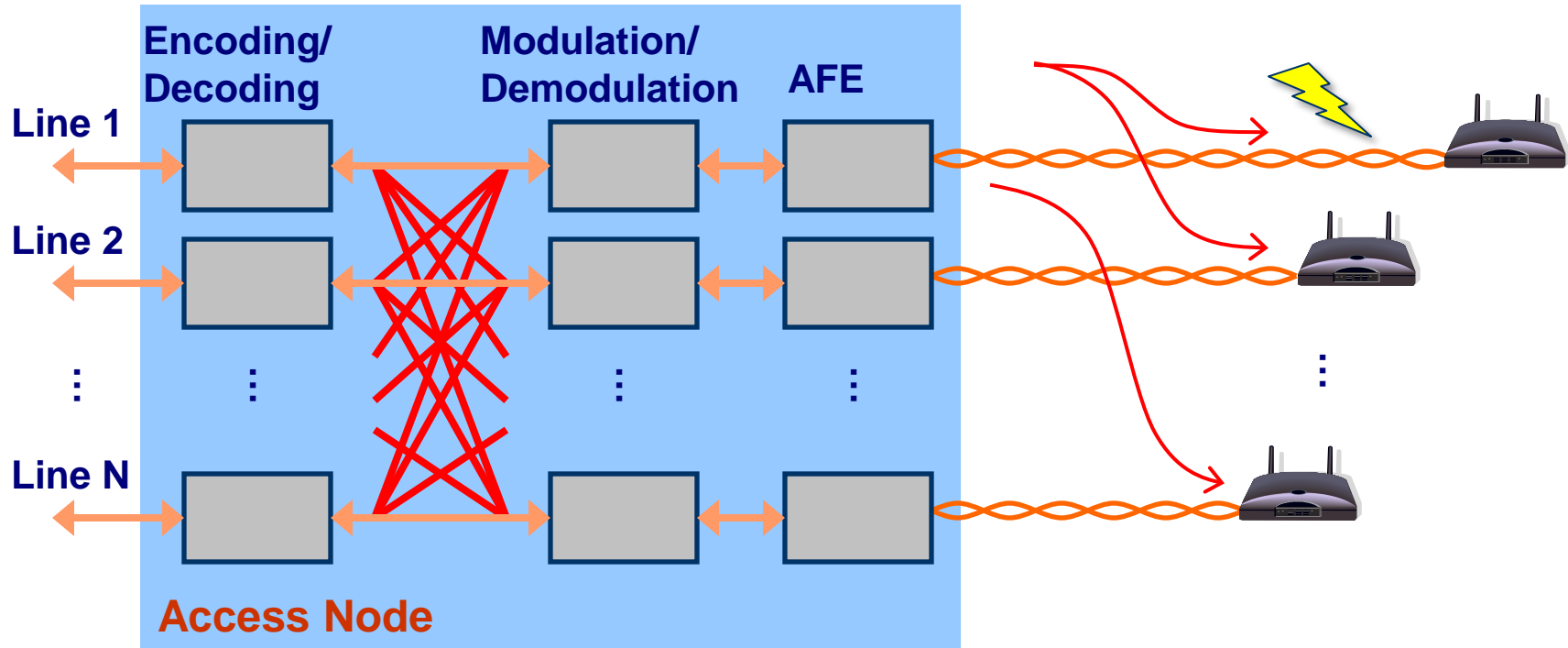

Limited resources for
vectoring operations

Performance
trade-offs
among
customers

Management
system needed
to realize full
benefits

Dynamic Spectrum Management (DSM)

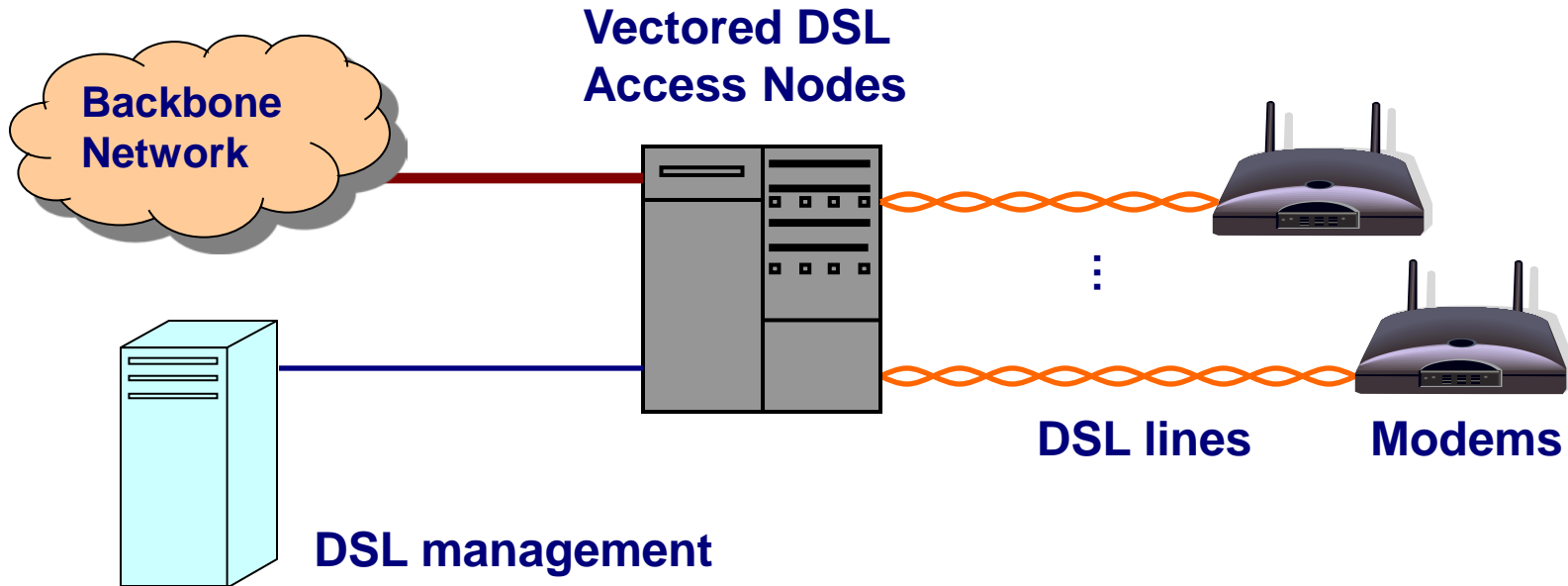

Collect

- management data from all lines;
- store for long period.



Analyze

- recent data and history;
- detect problems;
- project performance.



Act

- reconfigure lines to improve speed/stability;
- report faults.



New Management Challenges (DSM Level 3)

Manage trade-offs among
vectored lines



Achieve co-existence of non-
vectored lines and vectored lines



Manage for noise sources that
become dominant after
eliminating the crosstalk

Data Parameters

Crosstalk coupling (XLOG)

- Received crosstalk PSD divided by received signal PSD

Noise correlation

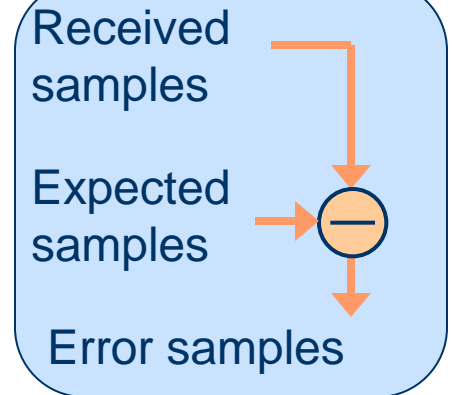
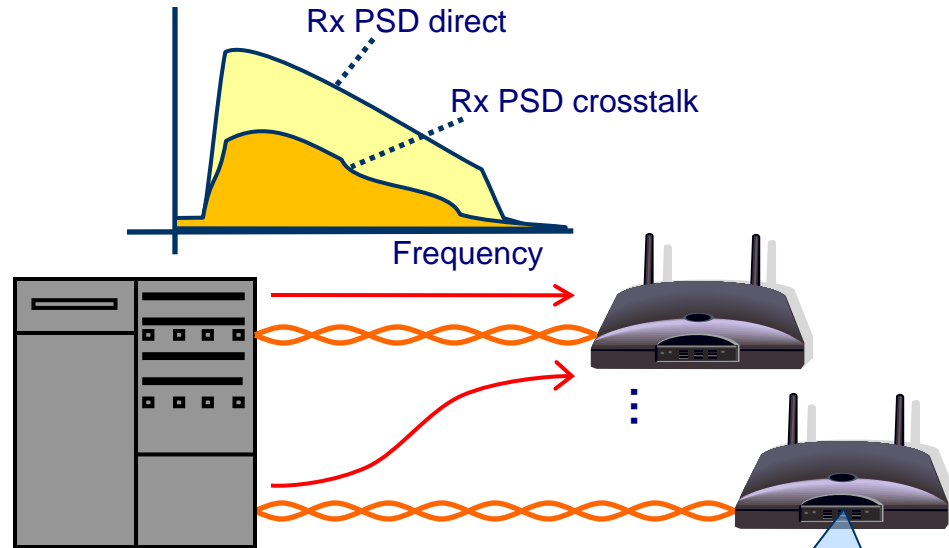

- Correlation of error samples of different receivers

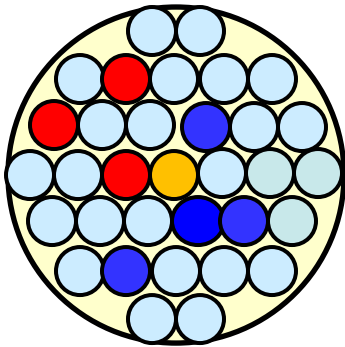

Crosstalk Diagnosis

Cable cross-section



-  Vectored lines
-  Vectored/non-vectored line creating strong crosstalk
-  Non-vectored lines

Identify source pair for high crosstalk (“rogue” pair).

Noise correlation can indicate common outside source.

Pair likely causing disruption/degradation on non-vectored lines as well.

Performance Prediction

Use data parameters (XLOG, noise correlation) to estimate data rates



Understand performance trade-offs and make decisions on priorities

DSL management

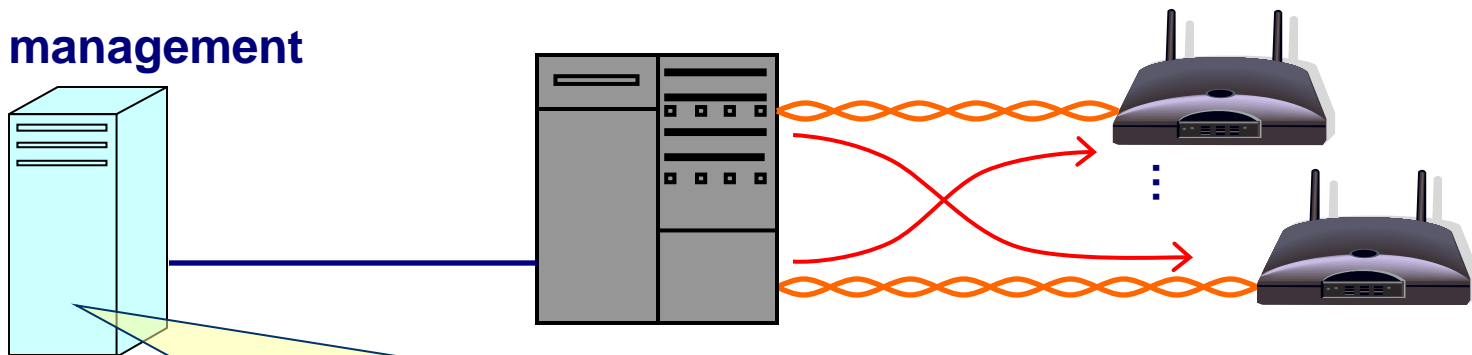

Line	Current Service	Service with vectoring – low priority	Service with vectoring – high priority
123-456-7890	50 Mbps	60 Mbps	65 Mbps
650-654-3400	30 Mbps	35 Mbps	42 Mbps
...

Control Parameters (1)

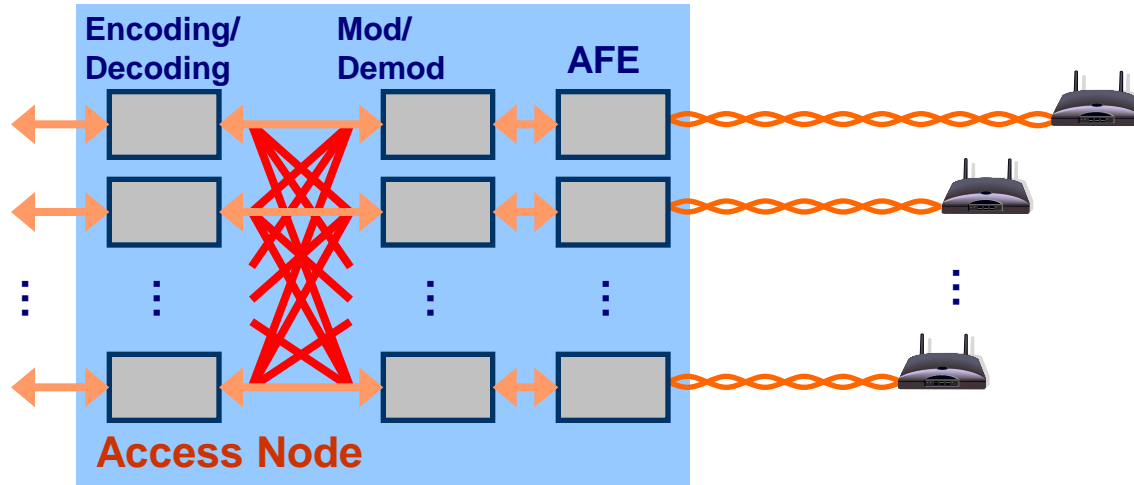

Vectoring enable/disable

- Choose on which lines to allocate vectoring resources

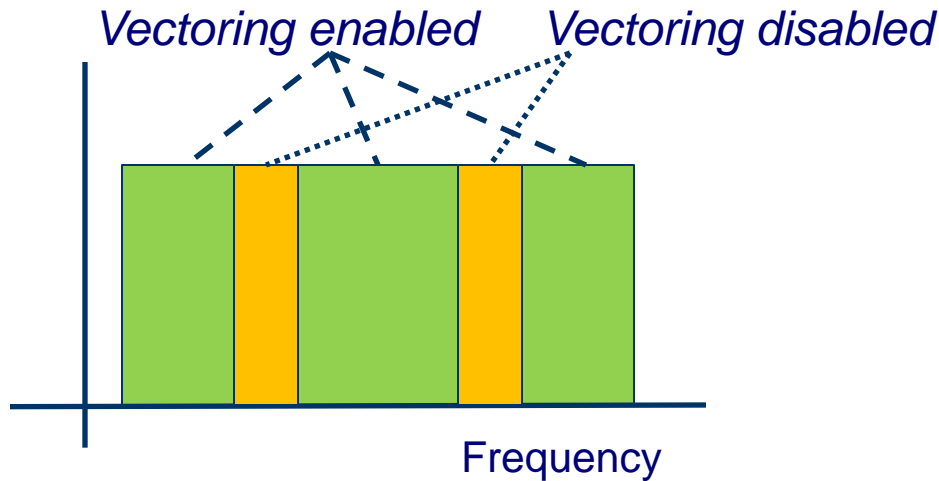

Frequency controls

- Choose on which frequencies to allocate vectoring resources

Control Parameters (2)

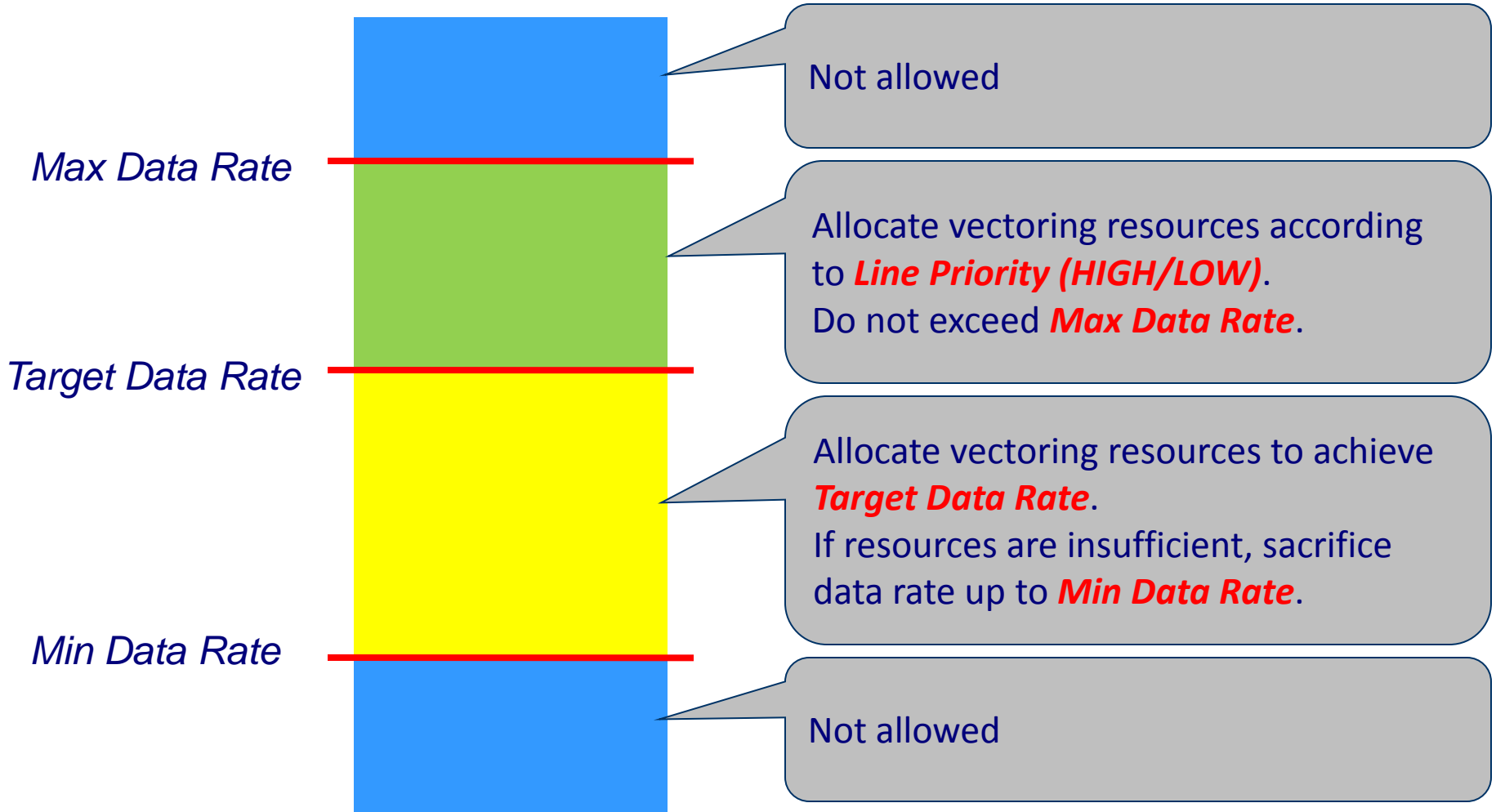

Controlling the Lines

Enable vectoring for lines that benefit the most

Enable vectoring for customer with high-end services

Disable vectoring for malfunctioning equipment

DSL management

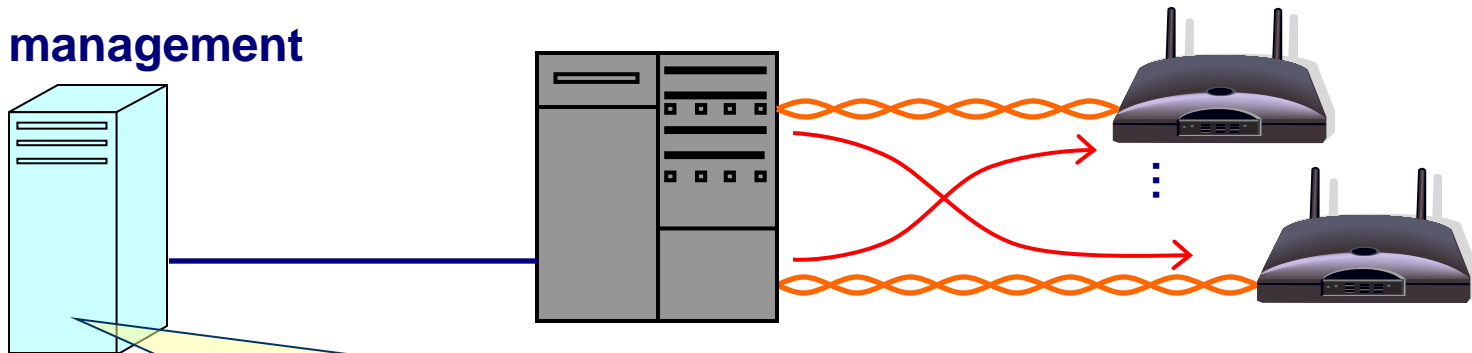

Line	Current Service	Benefit from vectoring	Purchased service	Enable vectoring?
123-456-7890	50 Mbps	15 Mbps	Premium	YES
650-654-3400	30 Mbps	2 Mbps	Basic	NO

Controlling the Frequencies

Disable vectoring in frequencies dominated by RFI, AM, or other time-varying interference.

Disable vectoring in frequencies where crosstalk from non-vectoring systems dominates.

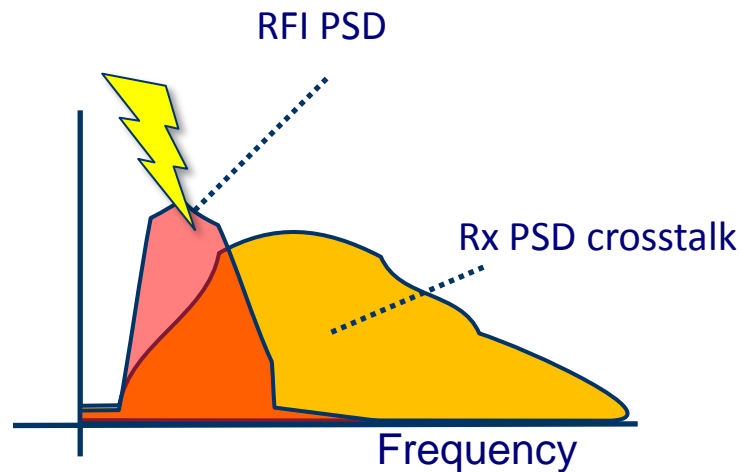

Controlling Rates and Priorities

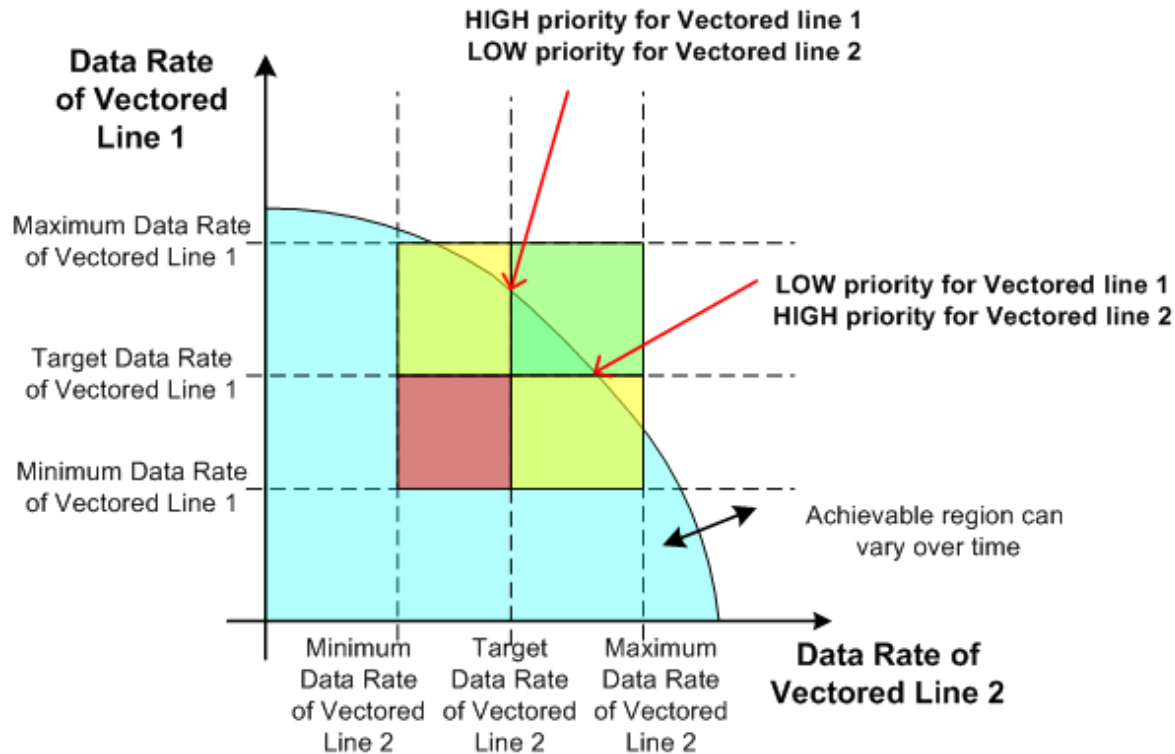

Achievable data rates depend on the allocation of vectoring resources

Must choose rate controls and line priorities based on achievable data rates and customer's purchased service

Co-existence of Vectored and Non-vectored lines (DSM Level 2+3)

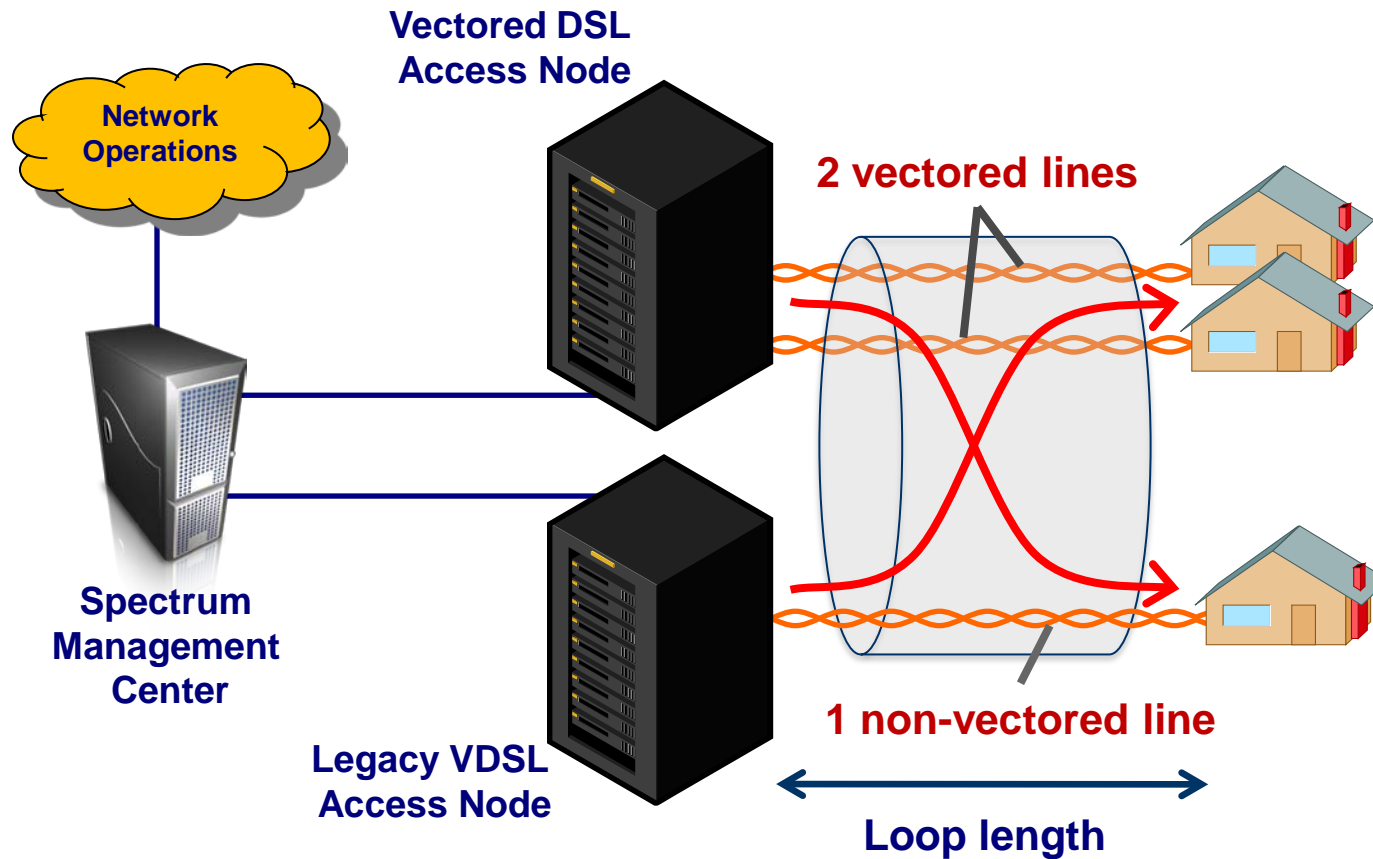

Non-vectored lines in the same binder increase the crosstalk level

Reducing power for non-vectored lines restores the rates of the vectored lines

Data Rate Comparison (DSM Level 2+3)

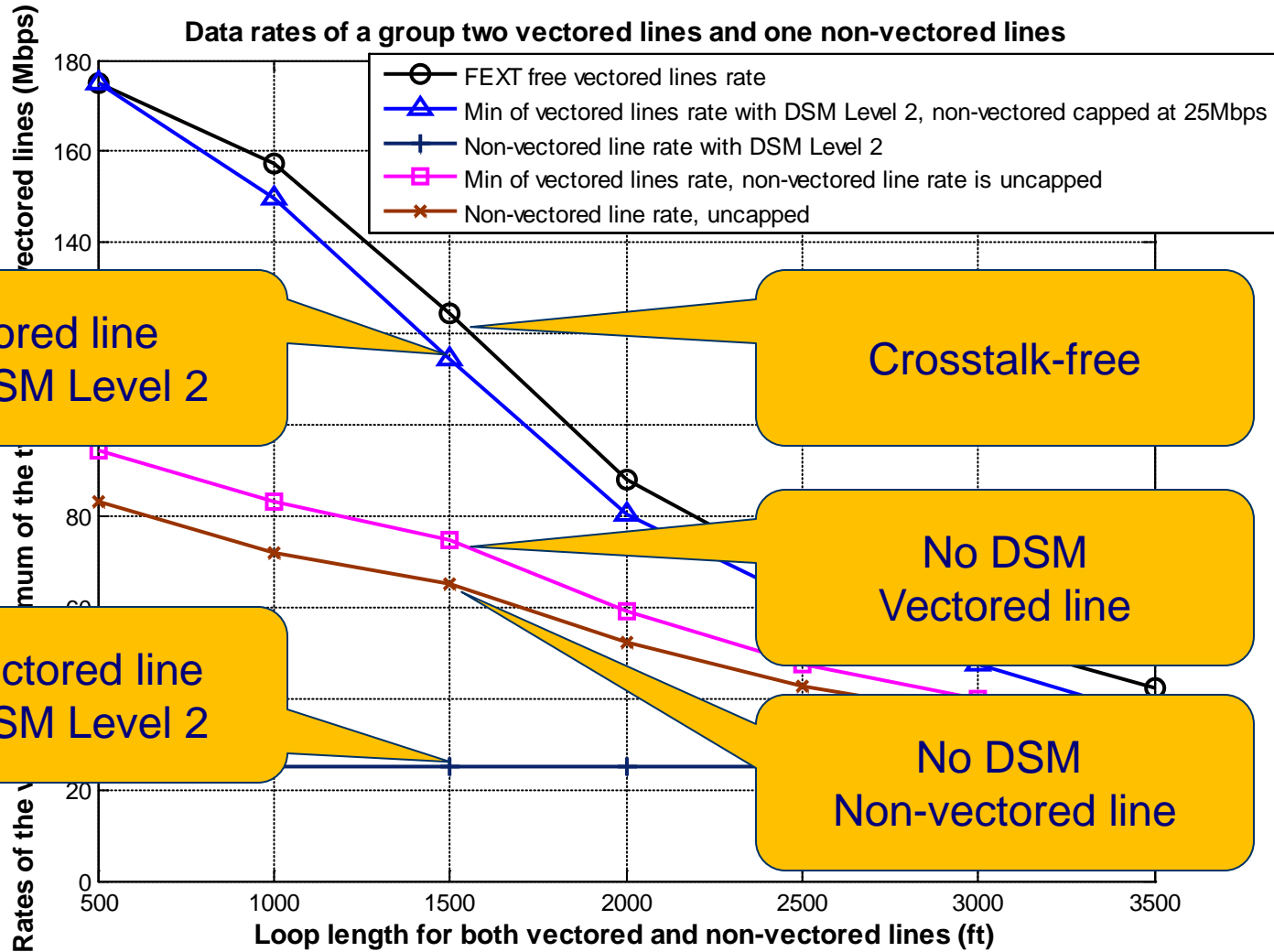

Vectored line with DSM Level 2

Crosstalk-free

No DSM Vectored line

Non-vectored line with DSM Level 2

No DSM Non-vectored line

Managing for External Noise (DSM Level 1+3)

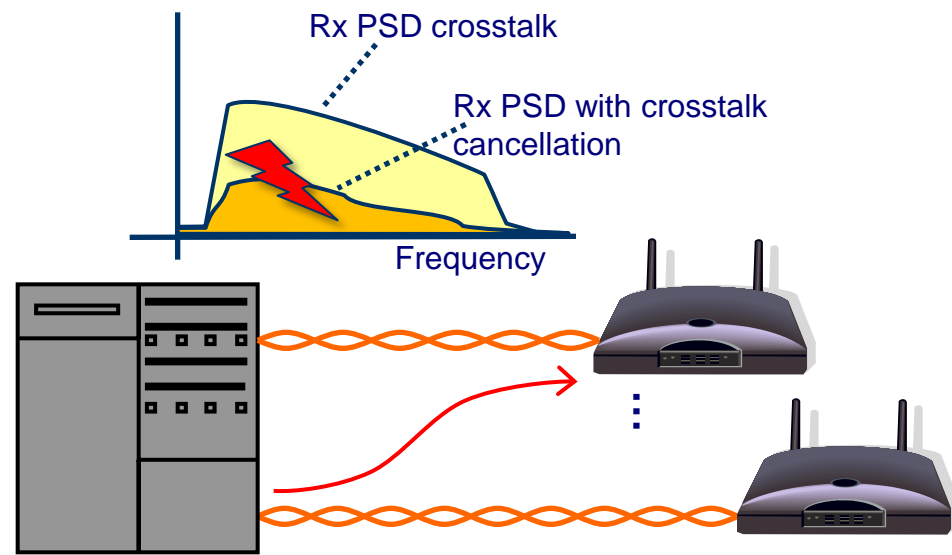
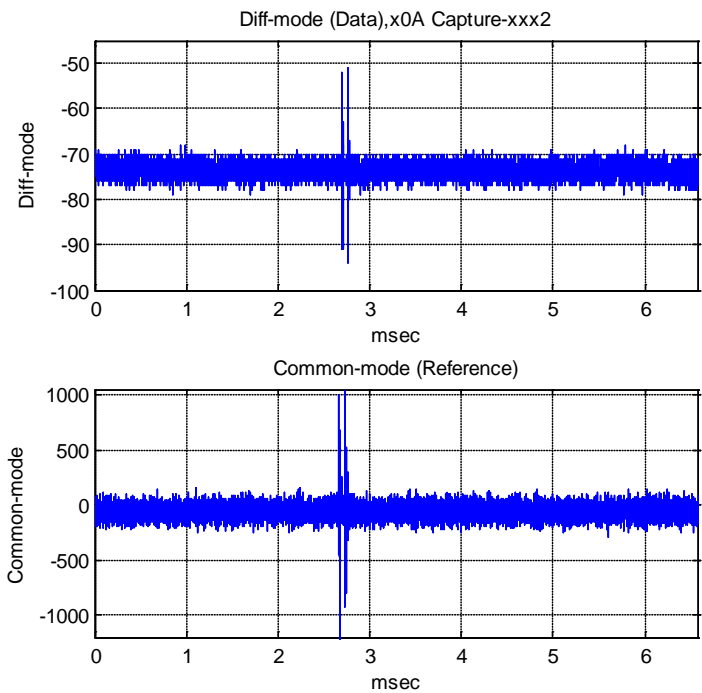

Crosstalk often hides other noise sources



With crosstalk eliminated, lines are more sensitive to noise effects



Management for impulse and other time-varying noise becomes even more important

Conclusions

Vectored DSL brings copper pairs to the 100 Mbps performance region



Proper management brings out the full benefits of the technology