

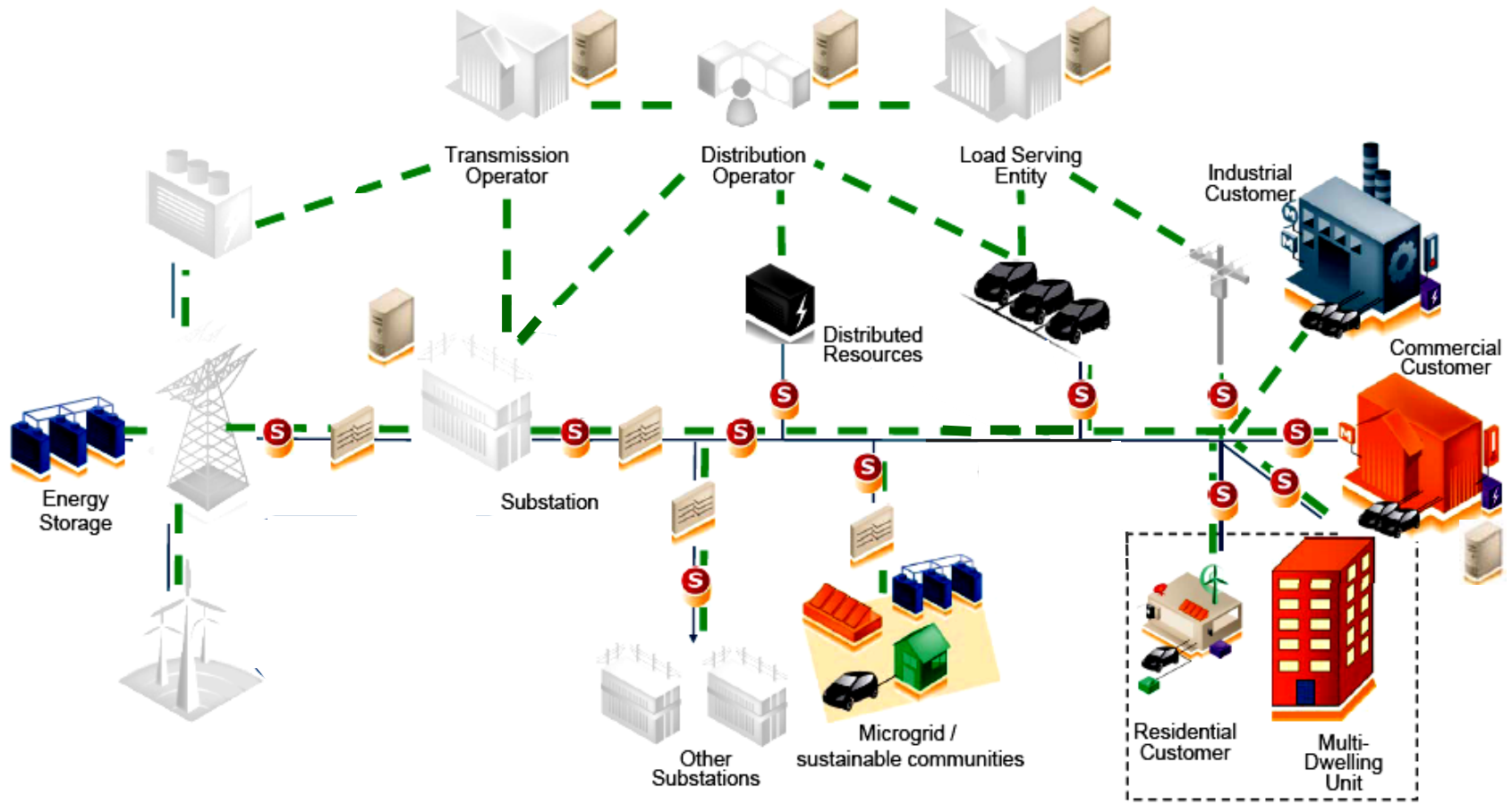

# A DC Switching Renaissance

Emerging Renewable Energy and  
Storage Applications Demand  
Modern DC Switching Technologies  
for Control and Protection

# DC Growth Areas From a Power System Perspective



..... Communications  
  Smart Switching Device  
  Sensor  
  Advanced Computing

Source: PG&E

# DC Growth Areas From a Power System Perspective

## Alternative and Renewable Energy

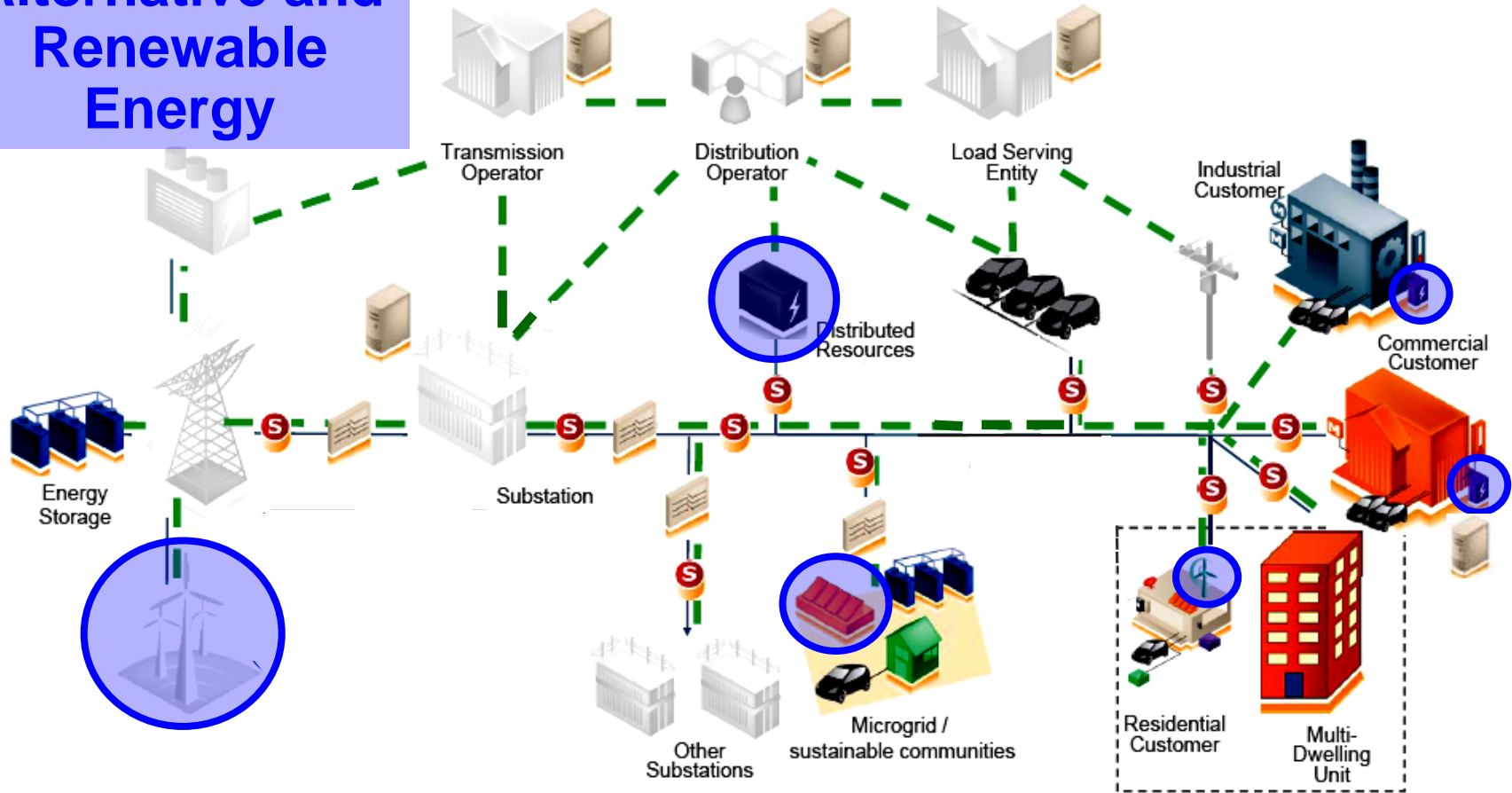

Source: PG&E

# DC Growth Areas From a Power System Perspective

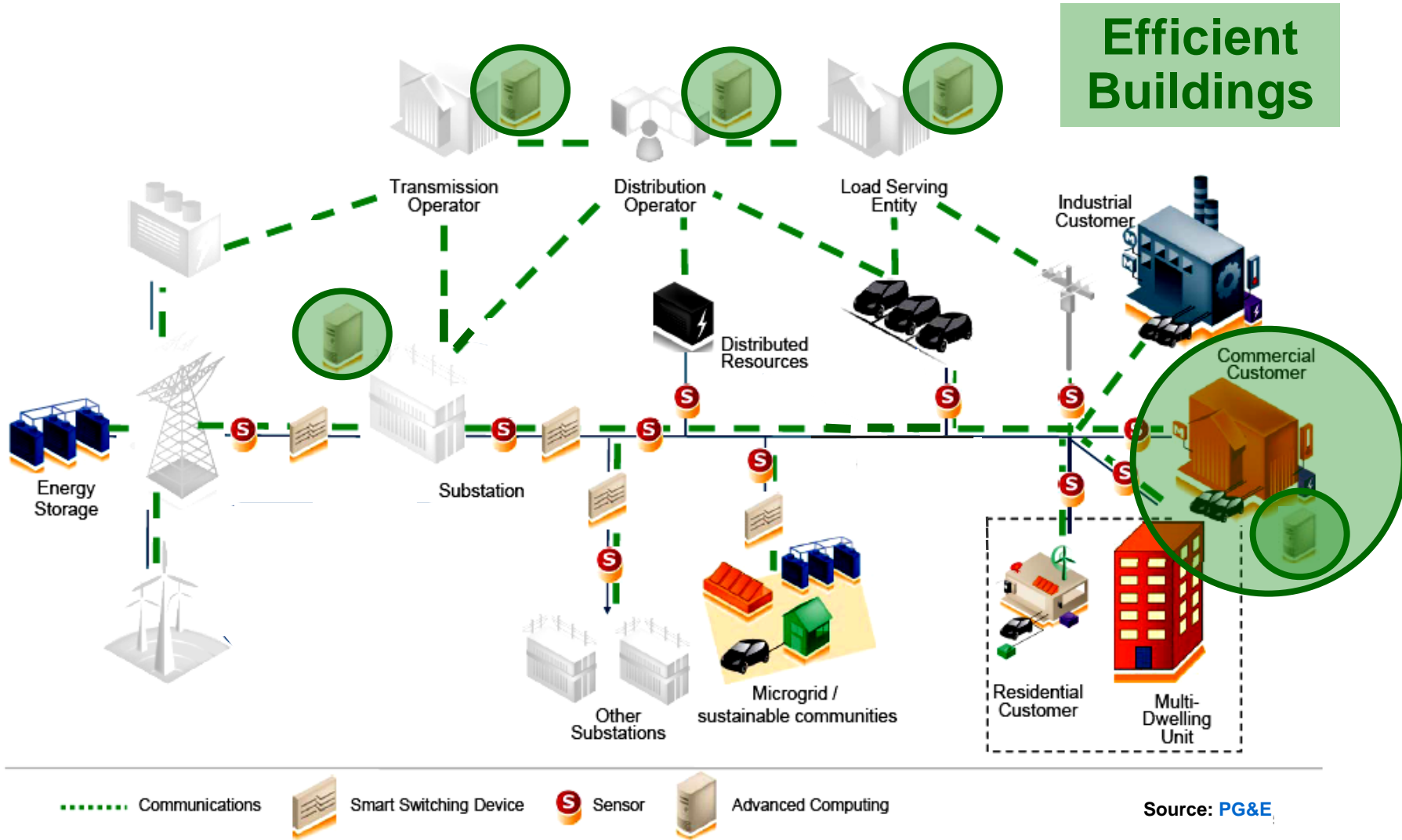

# DC Growth Areas From a Power System Perspective

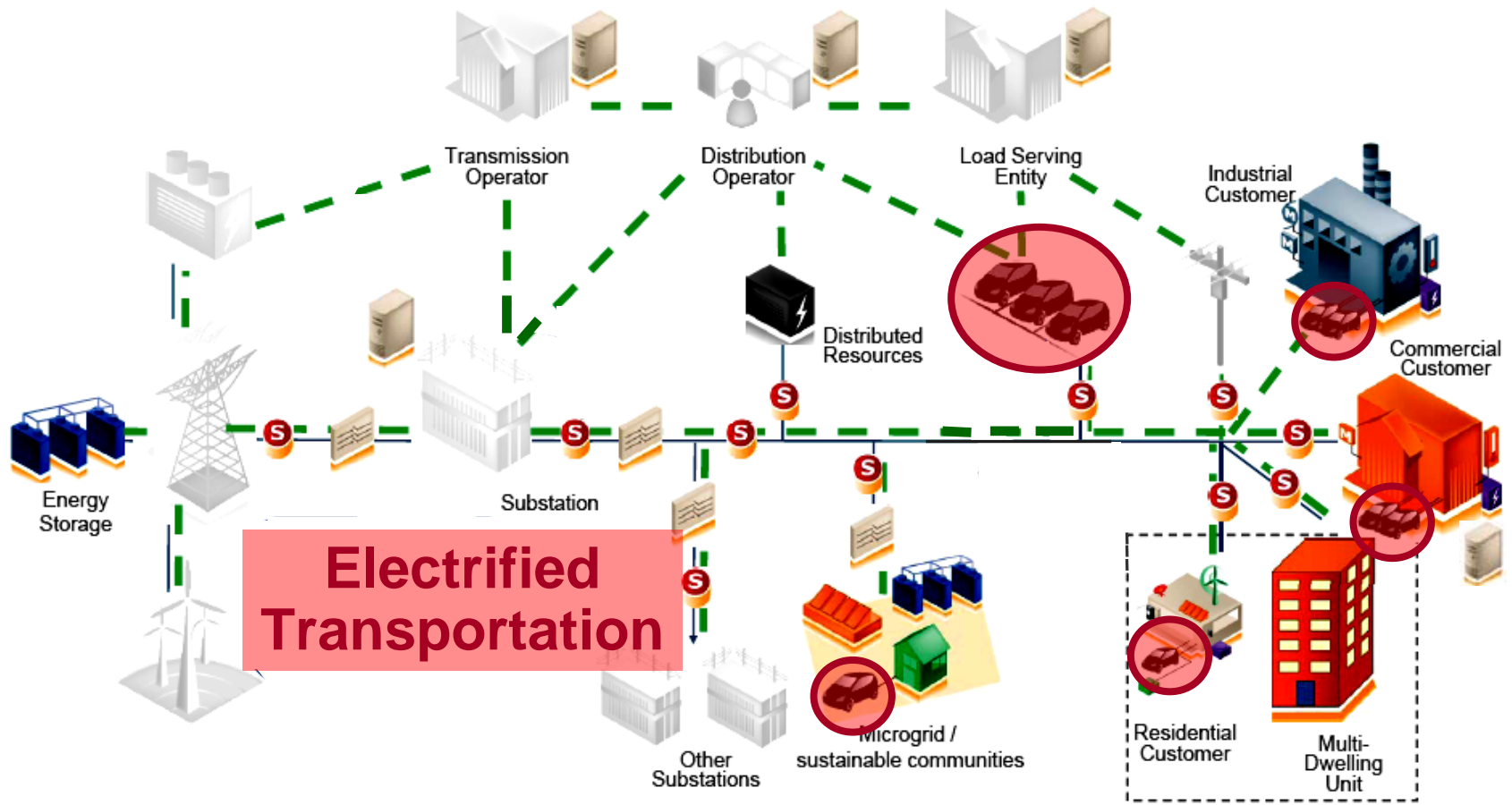

**Electrified  
Transportation**

..... Communications   
  Smart Switching Device   
  Sensor   
  Advanced Computing

Source: PG&E

# DC Growth Areas From a Power System Perspective

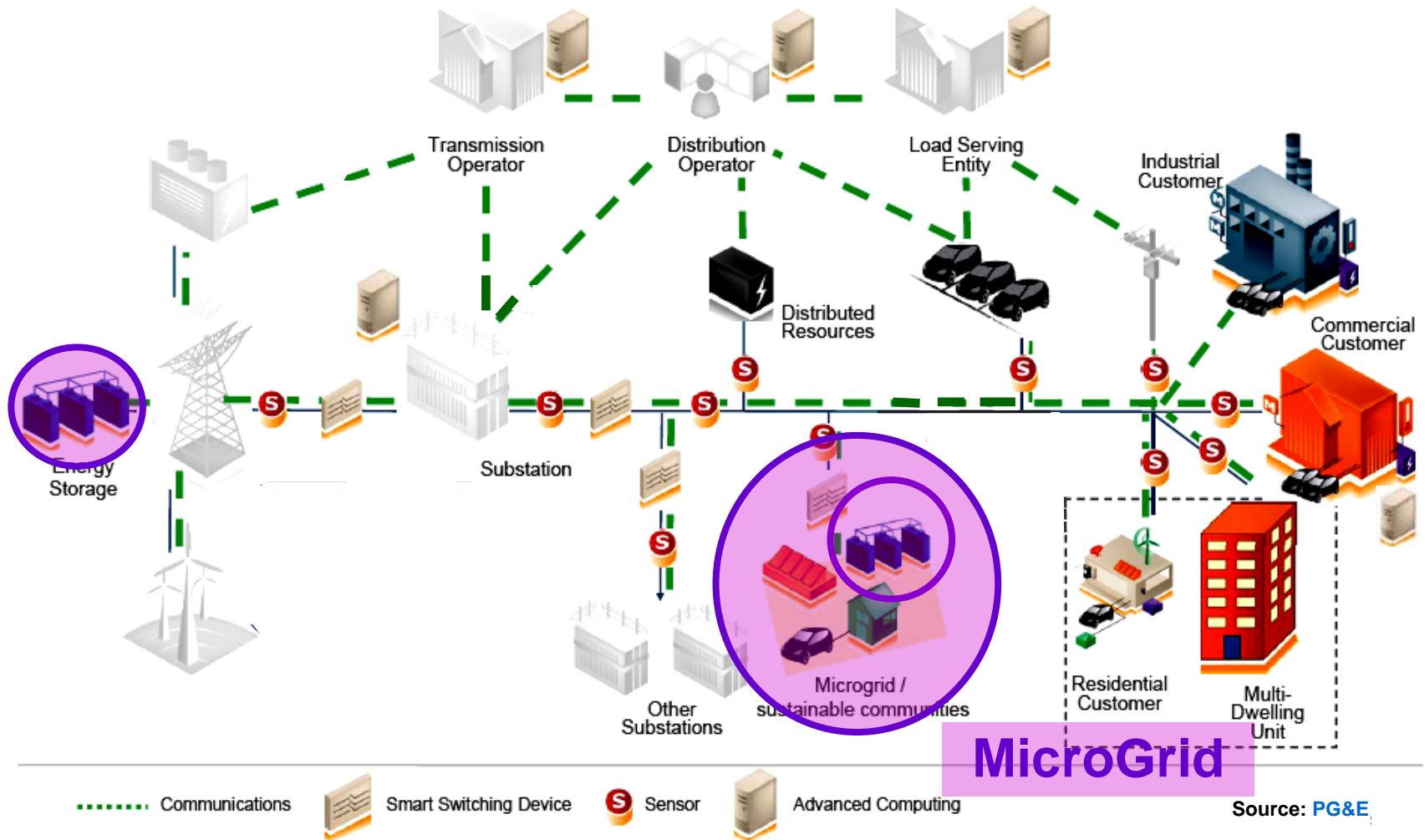

# DC Growth Areas From a Power System Perspective

Alternative and Renewable Energy

Efficient Buildings

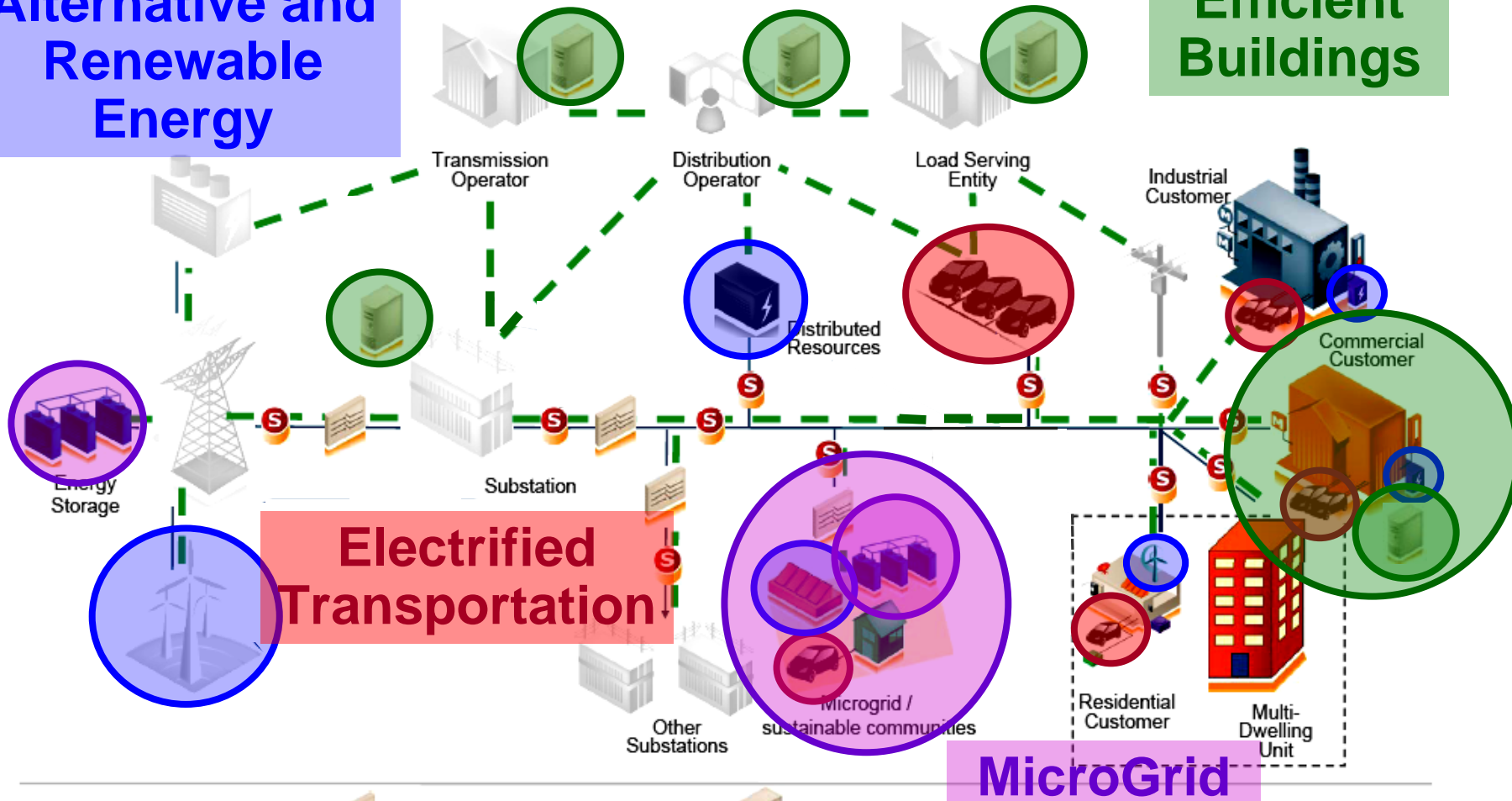

Electrified Transportation

MicroGrid

- ..... Communications
- Smart Switching Device
- S Sensor
- Advanced Computing

Source: PG&E

# DC Growth Areas

## Key Markets Identified

---

- Alternative and Renewable energy
  - Solar
  - Fuel Cell
  - Nuclear
- Efficient Buildings
  - Data Centers
- Electrified Transportation
  - EVs in all their forms (XEVs)
  - Light Rail
- Microgrid
  - Grid Scale Energy Storage
  - Microgrids

# DC Growth Areas Categorization

---

- Soft Sources
  - Solar
  - Fuel Cell
- High energy, High short circuit sources
  - Grid Scale Energy Storage
  - EVs in all their forms (XEVs)
  - Light Rail
- Mixed source characteristics
  - Microgrids
  - Data Centers
  - Nuclear

# DC Growth Areas Categorization

---

- **Soft Sources**
  - No or slow response short circuit availability
- **High energy, High short circuit sources**
  - 100s of kW to 10s of MWs
  - High short circuit availability
  - Potential for High inductance
- **Mixed source characteristics**
  - Soft sources and High energy, High short circuit sources

# Presentation Outline

---

- DC Switching
- High Level Market Drivers
- Soft Sources
- High energy, High short circuit sources
- Mixed source characteristics

DC yes --- but Not This Far



## Thomas Edison:

“My personal desire would be to prohibit entirely the use of alternating currents. They are as unnecessary as they are dangerous. I can therefore see no justification for the introduction of a system which has no element of permanency and every element of danger to life and property.”

# Presentation Outline

---

- DC Switching
- High Level Market Drivers
- Soft Sources
- High energy, High short circuit sources
- Mixed source characteristics

# DC Switching

## Arc Extinction - Break Arcs

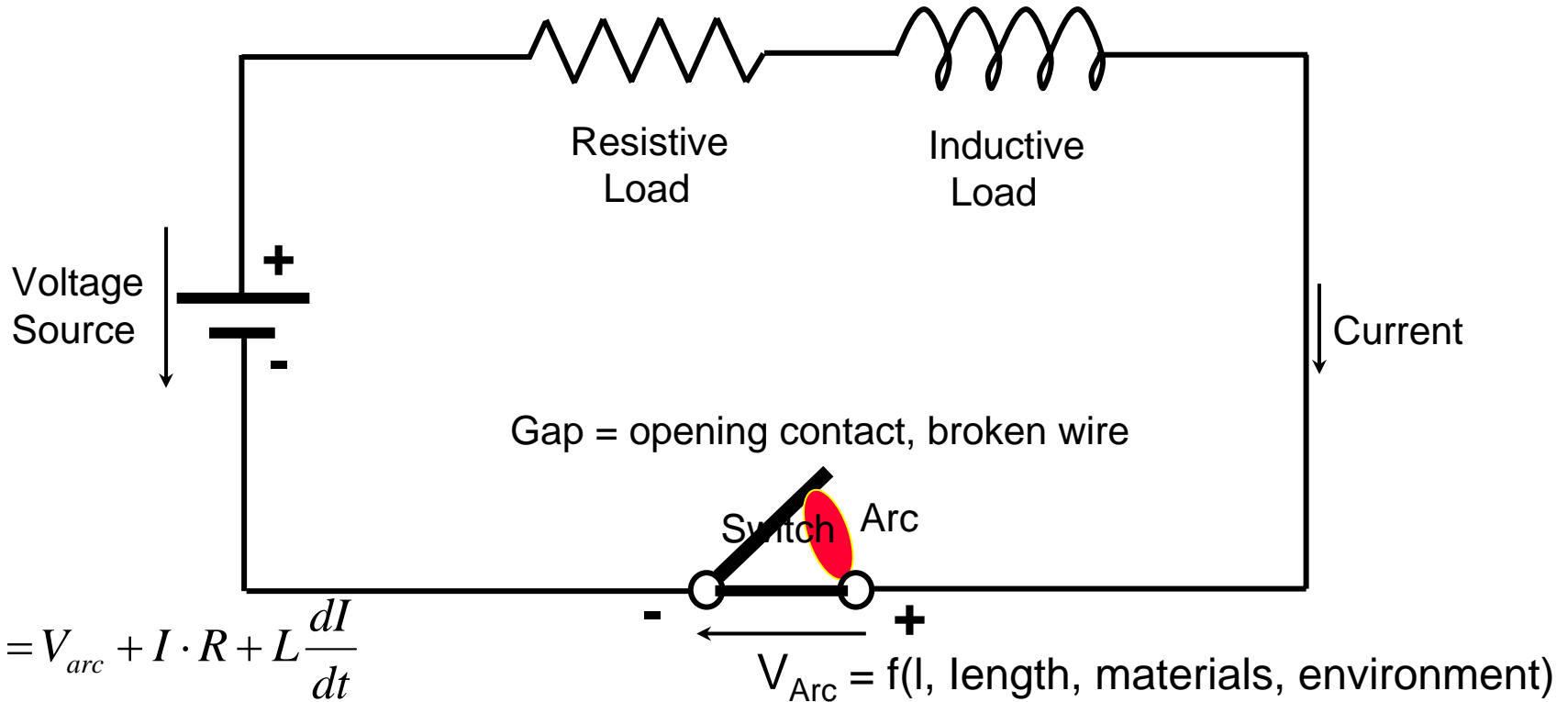

$$V_s = V_{arc} + I \cdot R + L \frac{dI}{dt}$$

$$\frac{dI}{dt} = \frac{V_s - I \cdot R - V_{arc}}{L} < 0$$

**Principle of DC Interruption:**

An **arc voltage equal or higher than the supply voltage** is necessary to stop the current flow.

# DC Switching

## DC Break Arc - Inductive

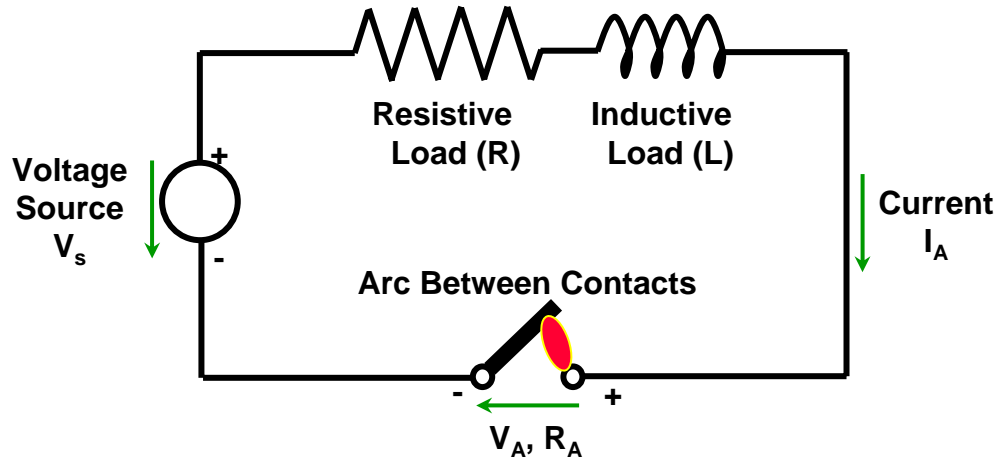

Energy dissipated by the arc:  $W_A = \int_0^T V_A I_A dt = \int_0^T (V_s - R I_A) I_A dt - L \int_{I_A}^0 I_A dI_A$

The faster  $V_A \rightarrow \infty$ :

- The lower  $W_A$

The minimum energy dissipated by the arc:  $W_A = \frac{L I_A^2}{2}$

# DC Switching

## DC Break Arc - Inductive

Open Circuit Voltage = 115VDC, Closed Circuit Current = 43A

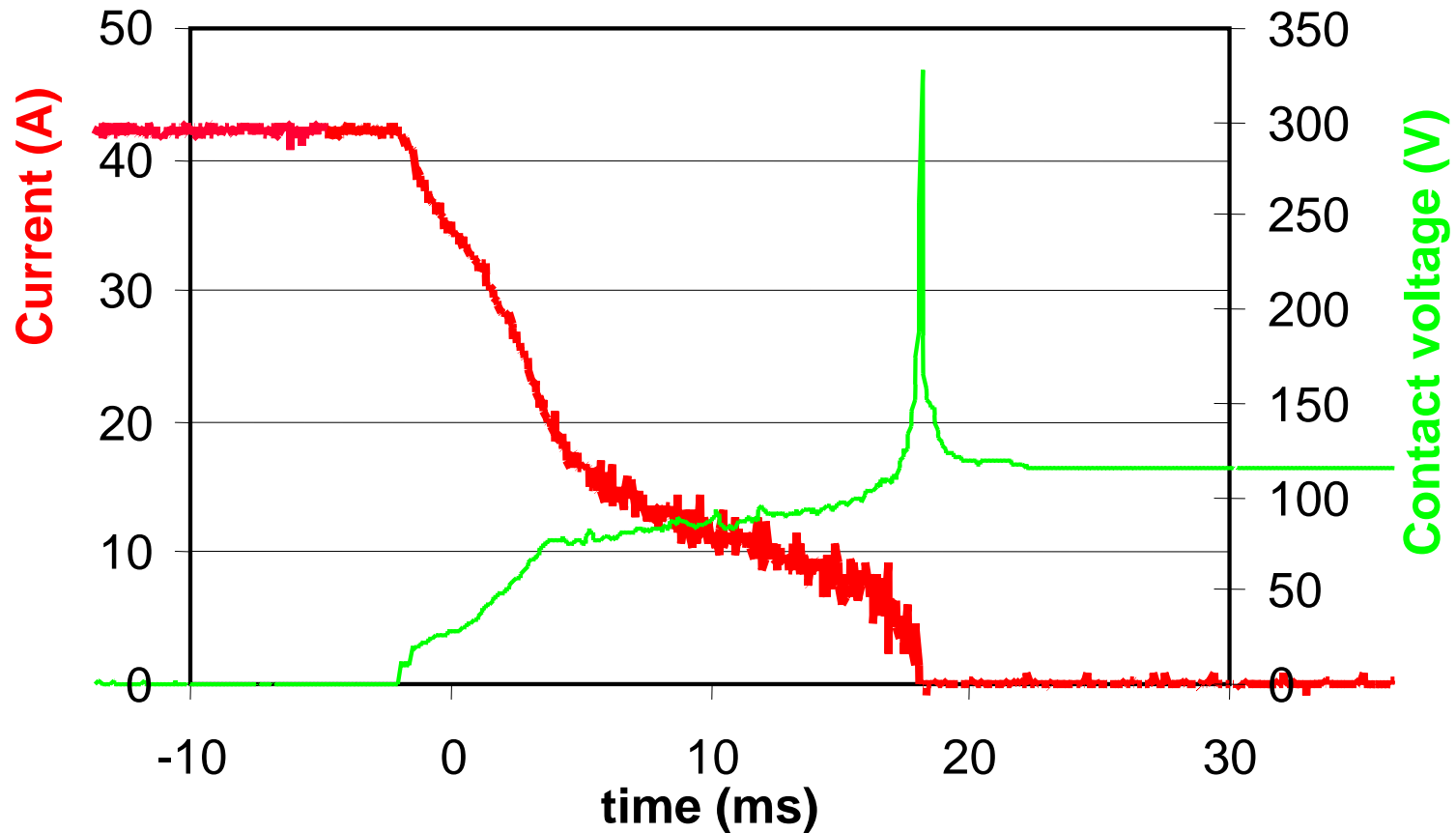

# DC Switching

## Arc Characteristic: 42V interruption example

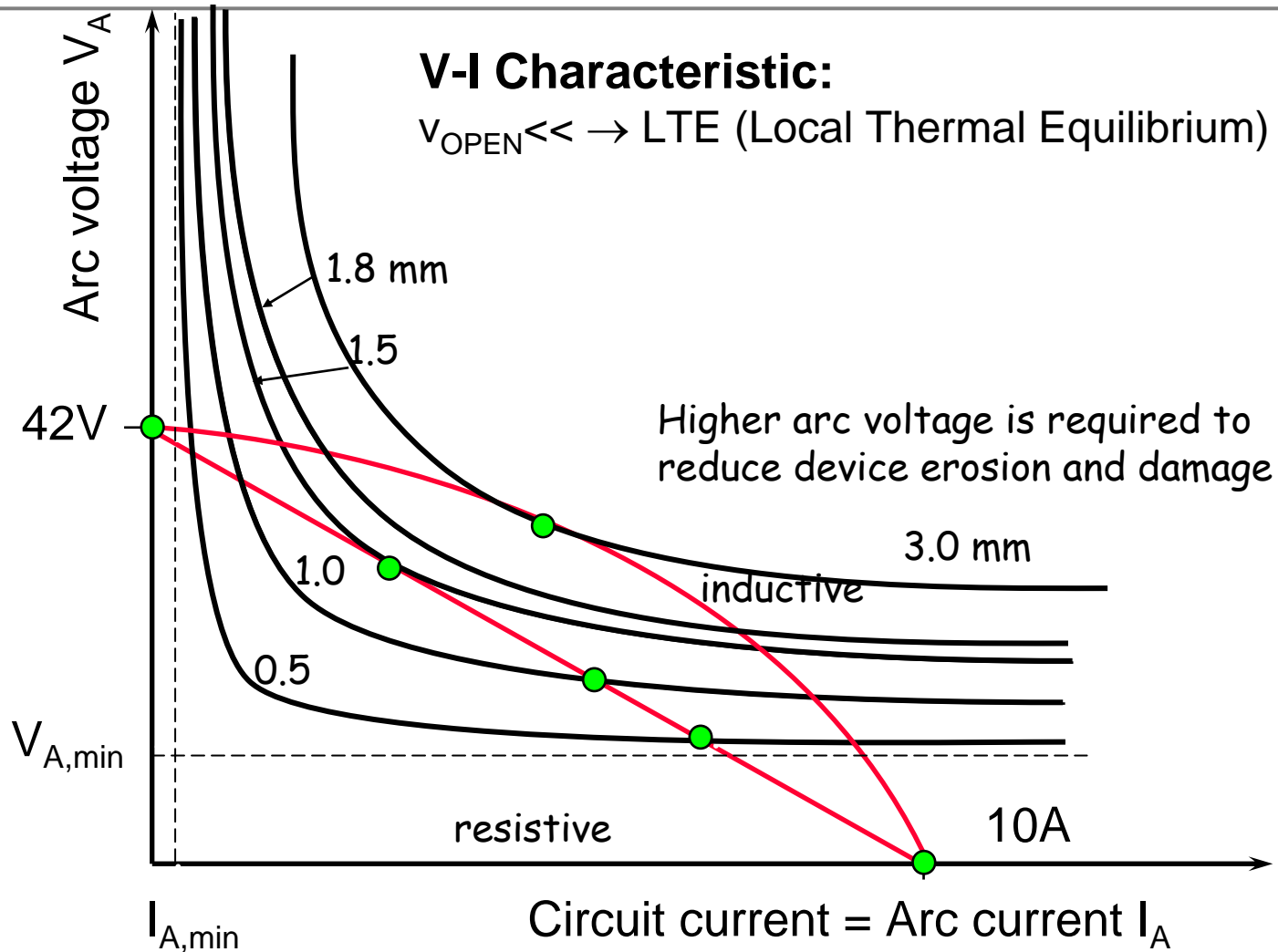

# Presentation Outline

---

- DC Switching
- **High Level Market Drivers**
- Soft Sources
- High energy, High short circuit sources
- Mixed source characteristics

# High Level Market Drivers

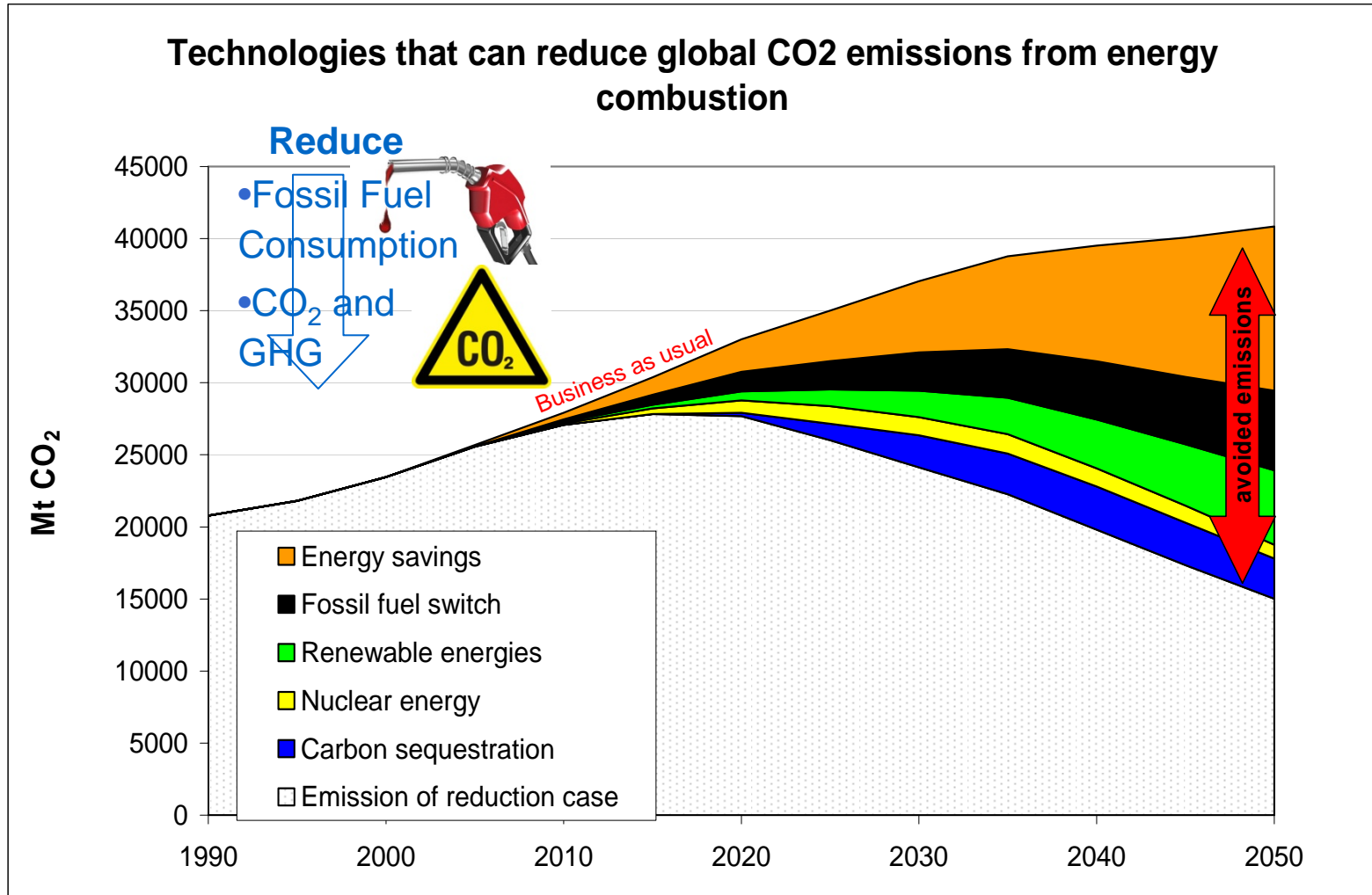

Source: The Institute for Prospective Technological Studies (IPTS) one of the 7 scientific institutes of the European Commission's Joint Research Centre

# High Level Market Drivers

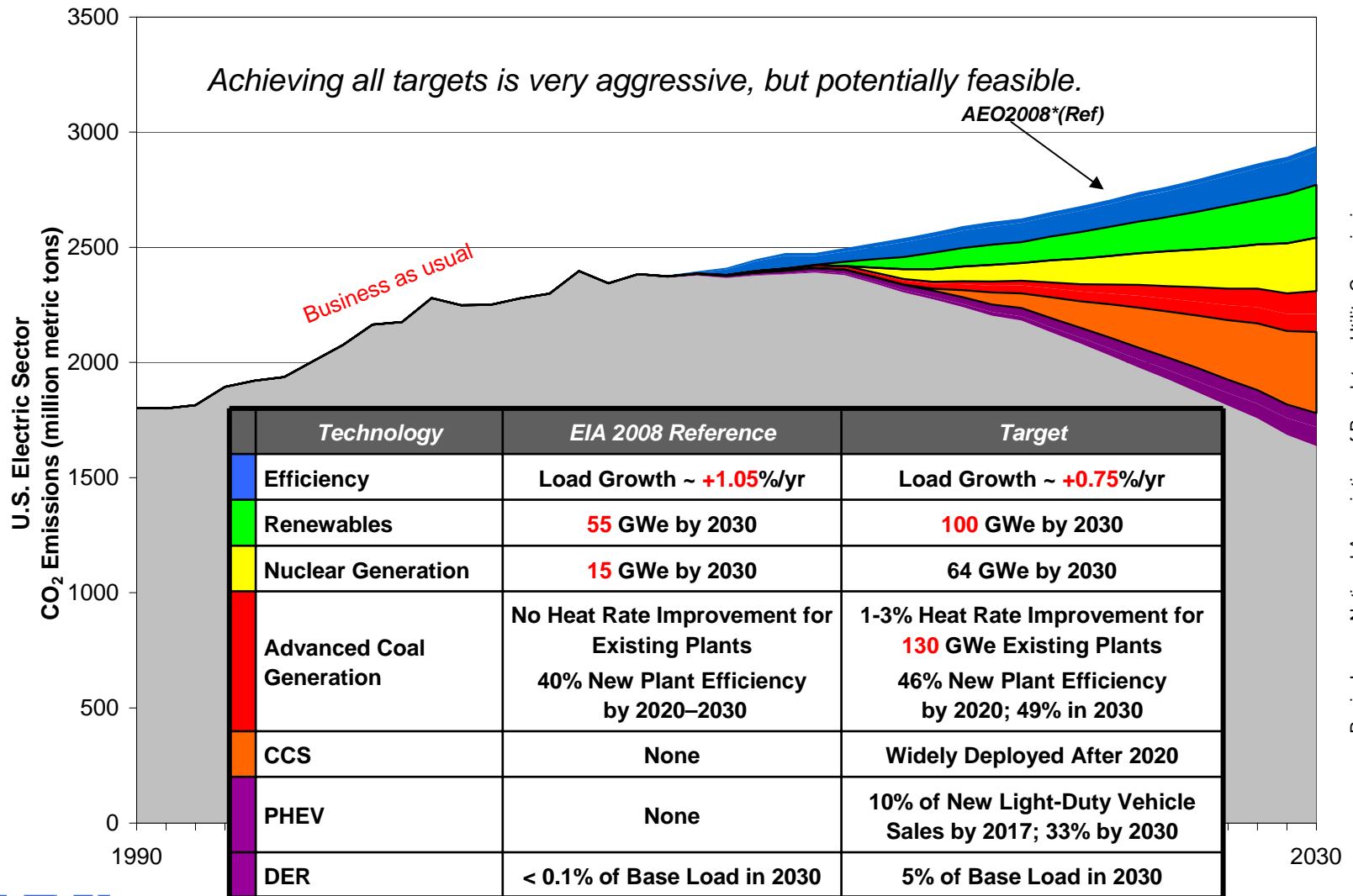

Revis James, National Association of Regulatory Utility Commissioners  
2008 Summer Meeting, Portland, OR

# High Level Market Drivers

Efficiency

Renewables

Nuclear

Electrical Transportation & Microgrid

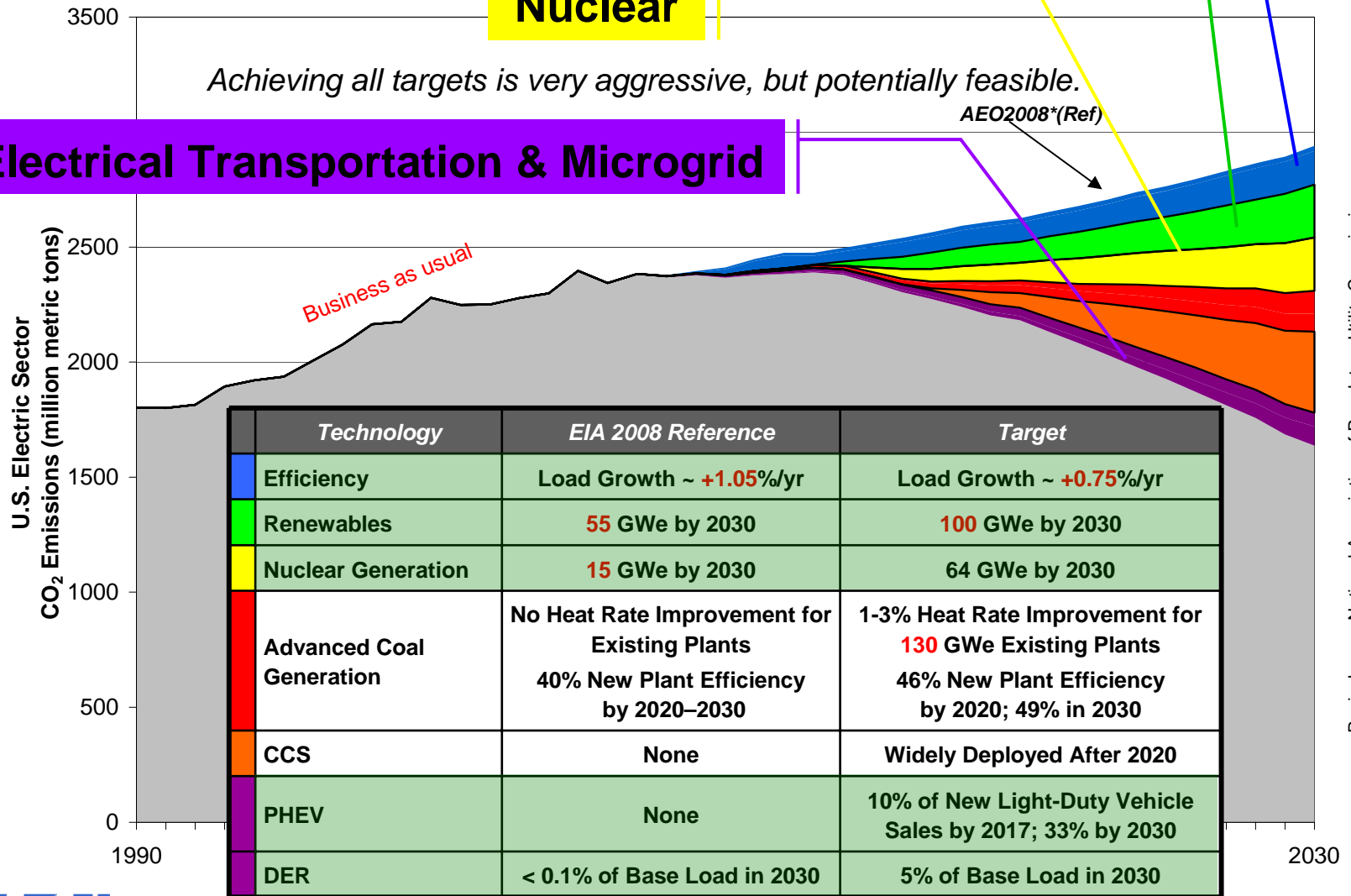

Revis James, National Association of Regulatory Utility Commissioners  
2008 Summer Meeting, Portland, OR

# High Level Market Drivers

## Photovoltaic systems Market

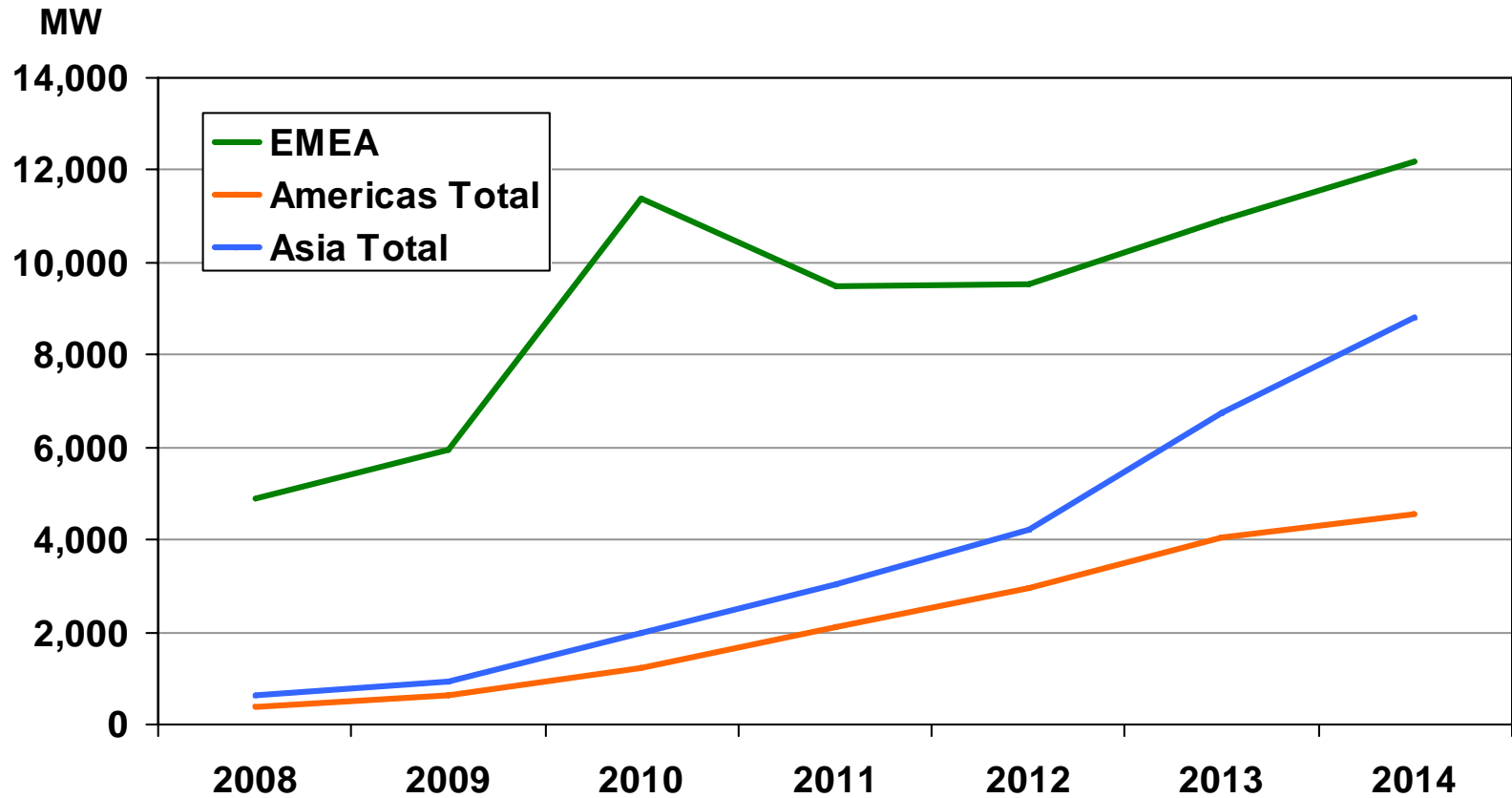

Source: IMS Research Jun-10

# Presentation Outline

---

- DC Switching
- High Level Market Drivers
- **Soft Sources**
- High energy, High short circuit sources
- Mixed source characteristics

# Soft Sources

(solar and fuel cell)

## Fundamentals

### Solar Power System

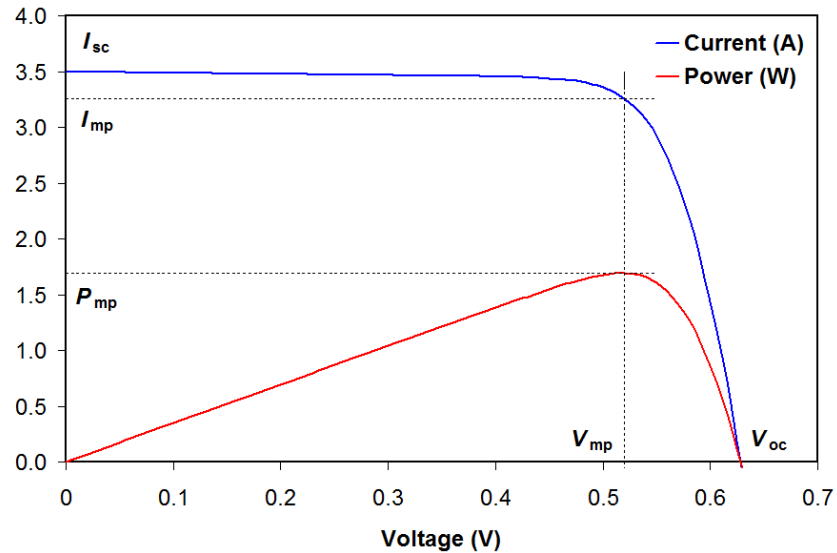
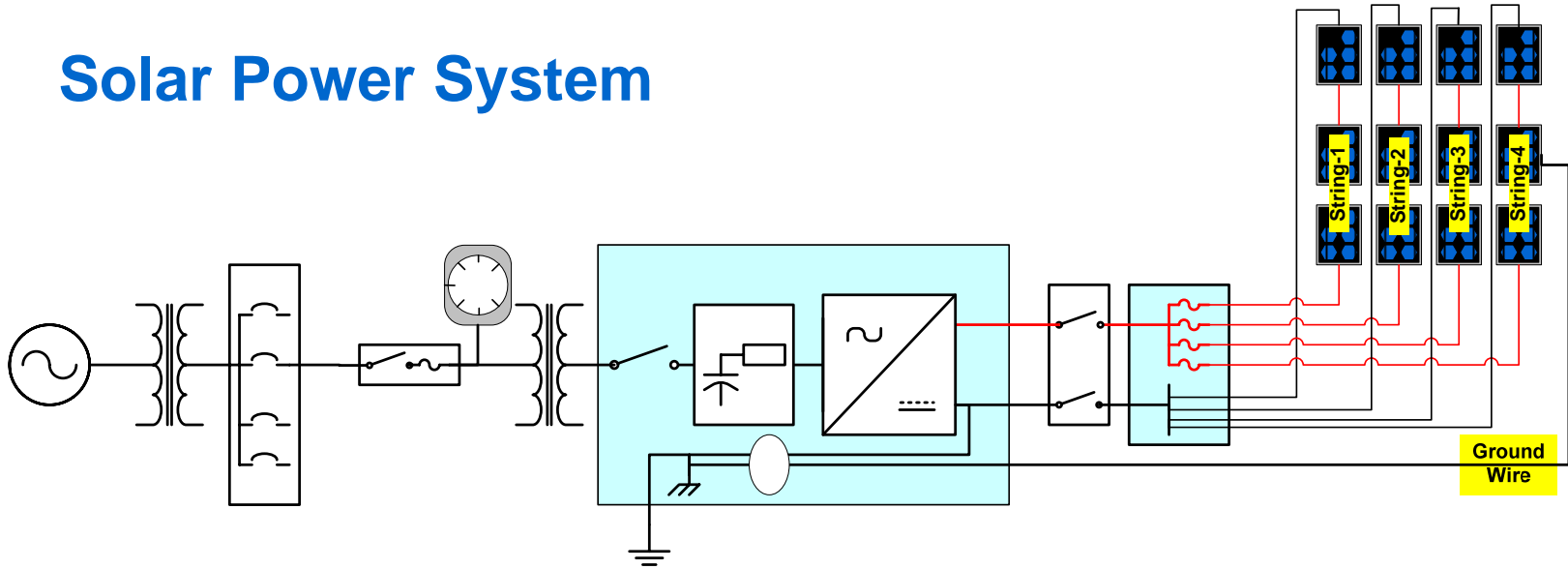

# Soft Sources

(solar and fuel cell)

## Fundamentals

### Solar Power System

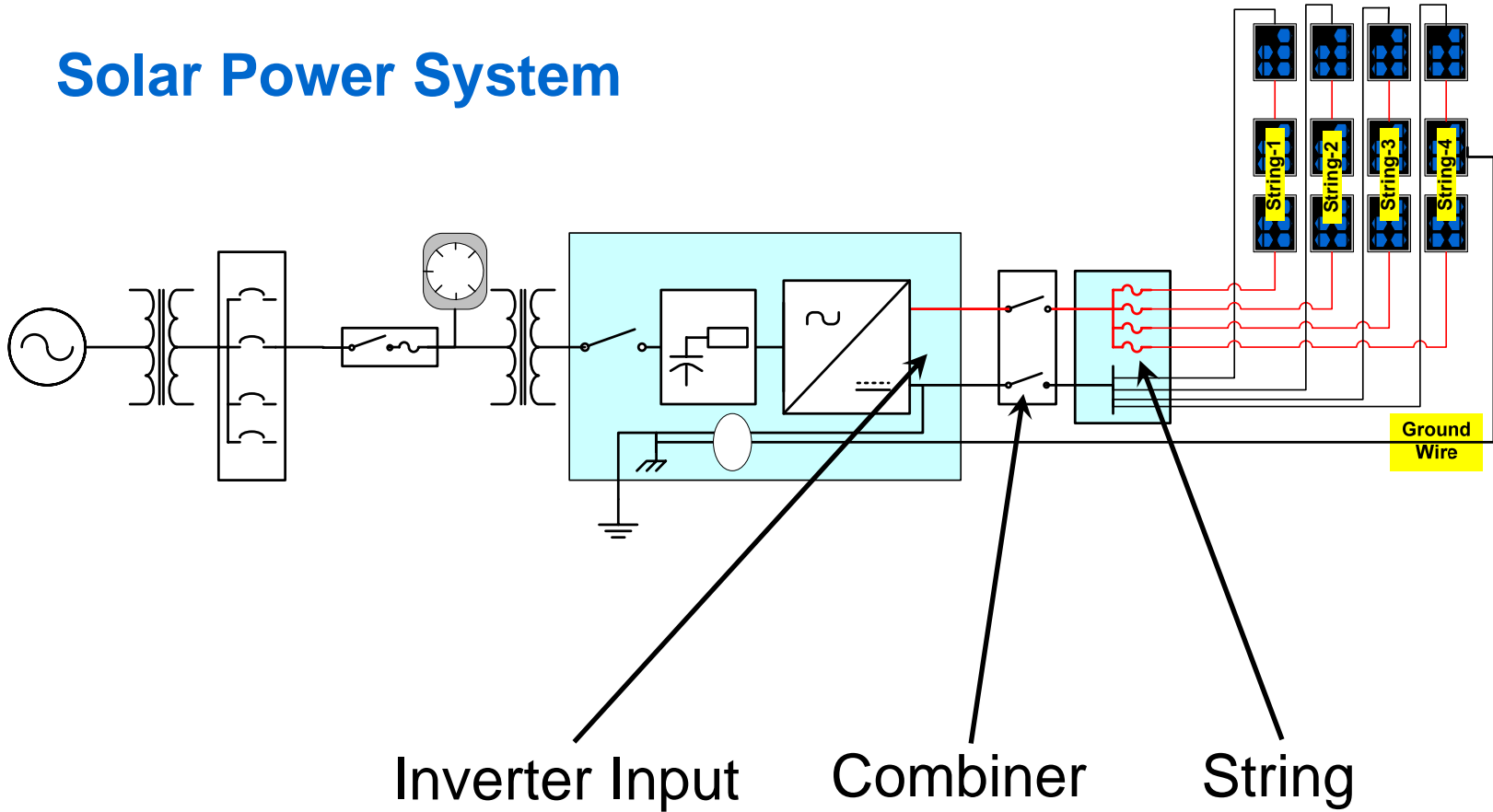

# Soft Sources

(solar and fuel cell)

## Fundamentals

### Solar Power System

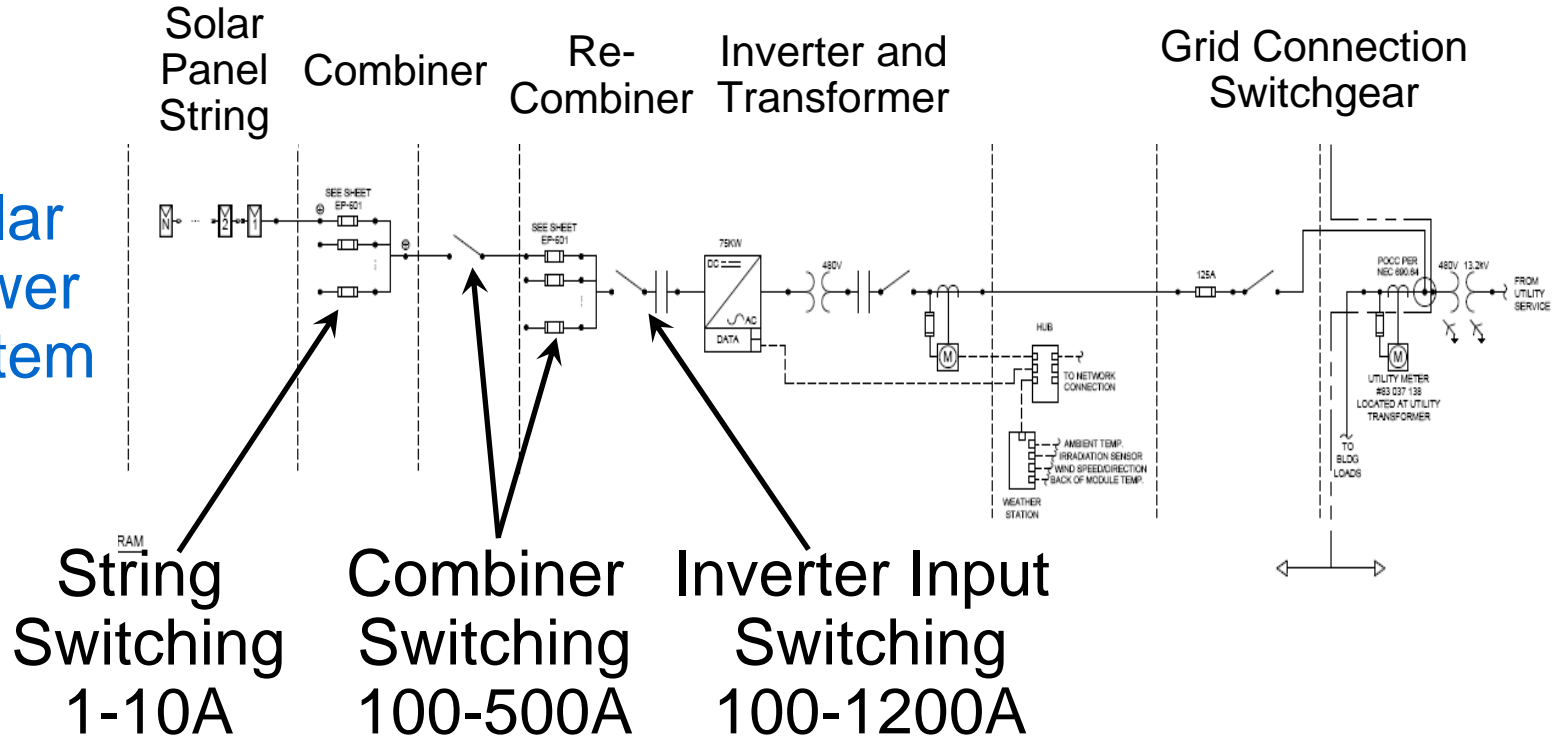

# Soft Sources

(solar and fuel cell)

## Fundamentals

Solar Power System

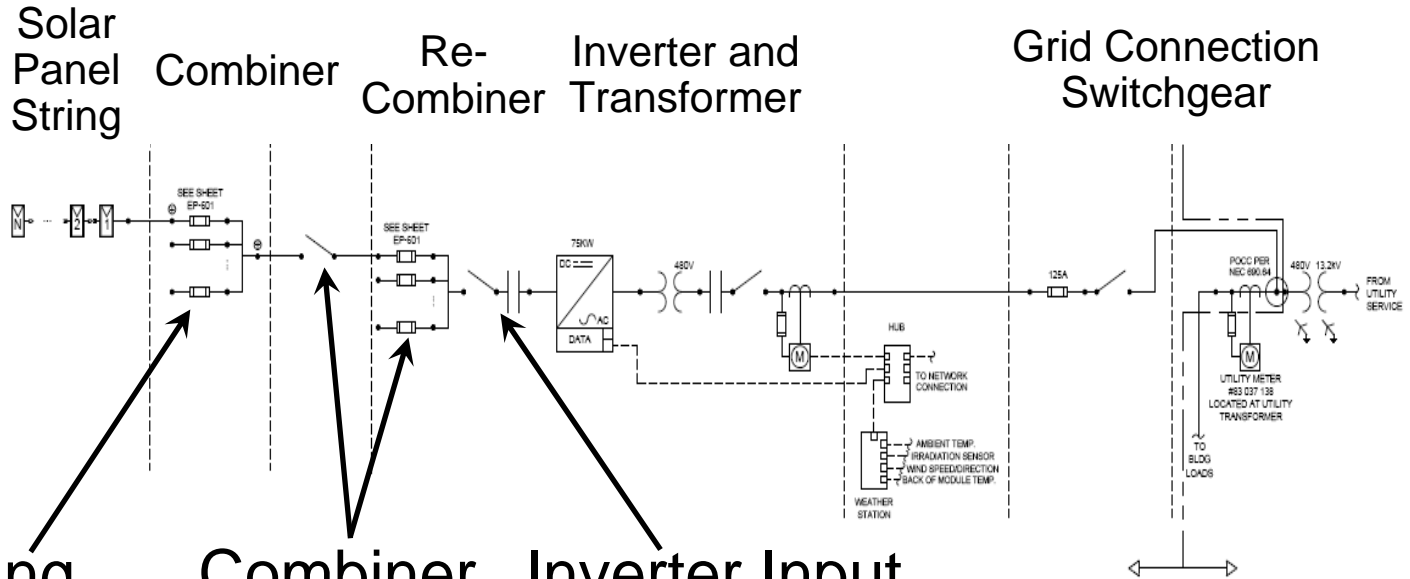

String Switching  
1-10A

Combiner Switching  
100-500A

Inverter Input Switching  
100-1200A

Fuel Cell Power System

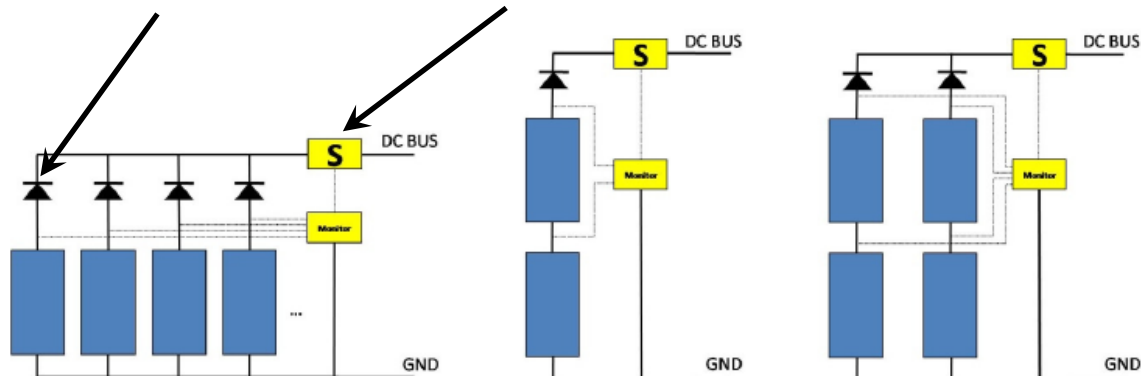

# Soft Sources

(solar and fuel cell)

## Fundamentals – Fuel Cell Example

### Distributed Power Generation at Consumption

(100kw modules)

- Clean, reliable and affordable
- Economical solid-oxide fuel cell technology
- Modular, scalable and portable
- 2-3 year payback with subsidies



### Opportunity areas

- Charging stations
- Complementary solution to solar PV
- Backup power to mitigate risks – UPS
- Utility installations
- Power management solutions
- Hydro-carbon gas systems

# Soft Sources

(solar and fuel cell)

## Fundamentals

- Voltage
  - 300VDC residential,
  - 600VDC commercial,
  - 1000VDC utility
  - 1500VDC future
- Limited or no Short Circuit
  - No or slow response
- Limited inductance
  - 600V Solar string,  $\sim 400\mu\text{H}$ 
    - (11 $\mu\text{H}$ /module, .25 $\mu\text{H}$ /ft wiring)

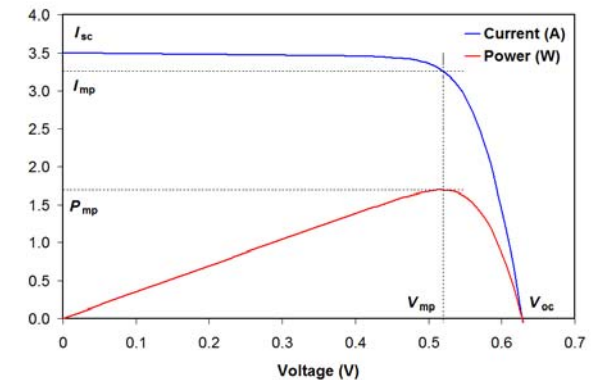

# Soft Sources

(solar and fuel cell)

## Potential Technologies

- Today's Technologies
  - Fuses
  - Repurposed AC disconnects
  - Repurposed AC breakers
- Future Technologies needs
  - Trip and reset
  - Remote control
  - Higher voltage
  - Balance of System cost

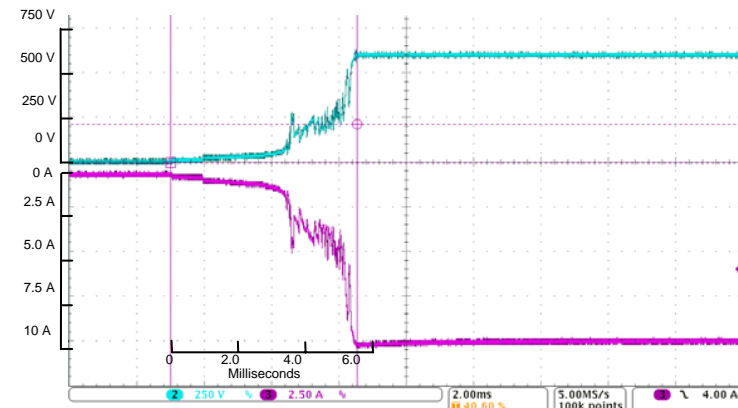

# Presentation Outline

---

- DC Switching
- High Level Market Drivers
- Soft Sources
- High energy, High short circuit sources
- Mixed source characteristics

# High energy, High short circuit sources

(Grid Scale Energy Storage, XEVs, Light Rail)

## Fundamentals – Grid Scale Energy Storage

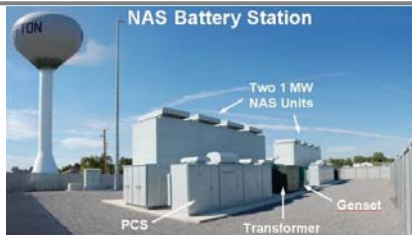

Storage Technologies	Main Advantages (relative)	Disadvantages (relative)	Power Application	Energy Application
Pumped Storage	High Capacity, Low cost	Special Site Requirements	Not Quite Feasible or Economical	Fully Capable and Reasonable
Metal Air	Very High Energy Density	Charging is Difficult		
Flow Batteries	High Capacity, Independent Power and Energy Ratings	Low Energy Density	Reasonable for this Application	
NaS	High Power and Energy Densities, High Efficiency	Production Costs, Safety Concerns	Fully Capable and Reasonable	Reasonable for this Application
Li-ion		High Production Costs, Special Charging Control		
Ni-Cd				
Lead-Acid	Low Capital Cost	Limited Cycle Life When Deeply Discharged		Not Quite Feasible or Economical
Flywheels	High Power			
E.C. Capacitors	Long Cycle Life, High Efficiency	Low Energy Density		

Source: Electricity Storage Association

# High energy, High short circuit sources

(Grid Scale Energy Storage, XEVs, Light Rail)

## Fundamentals – Grid Scale Energy Storage

---

### Grid Scale Energy Storage Applications

- Power Quality
  - seconds or less
- Bridging Power
  - seconds to minutes
- Energy Management
  - many hours.

# High energy, High short circuit sources

(Grid Scale Energy Storage, XEVs, Light Rail)

## Fundamentals – Grid Scale Energy Storage

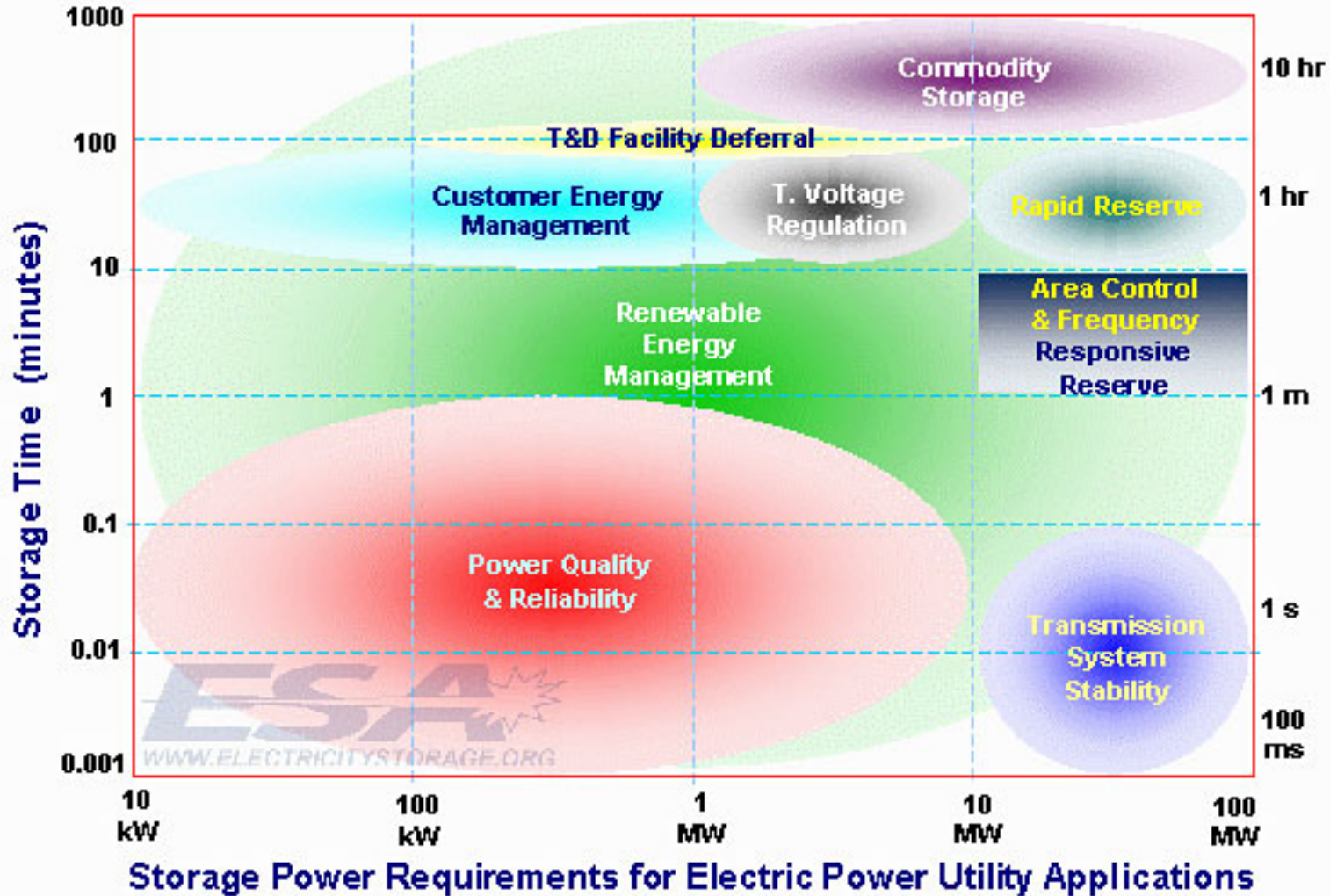

Data from Sandia Report 2002-1314

# High energy, High short circuit sources

(Grid Scale Energy Storage, XEVs, Light Rail)

## Fundamentals – Grid Scale Energy Storage

### System Ratings

Installed systems as of November 2008

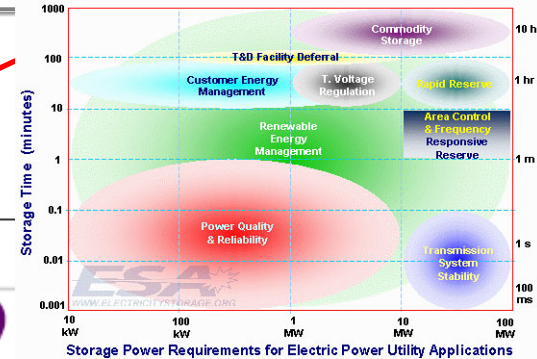
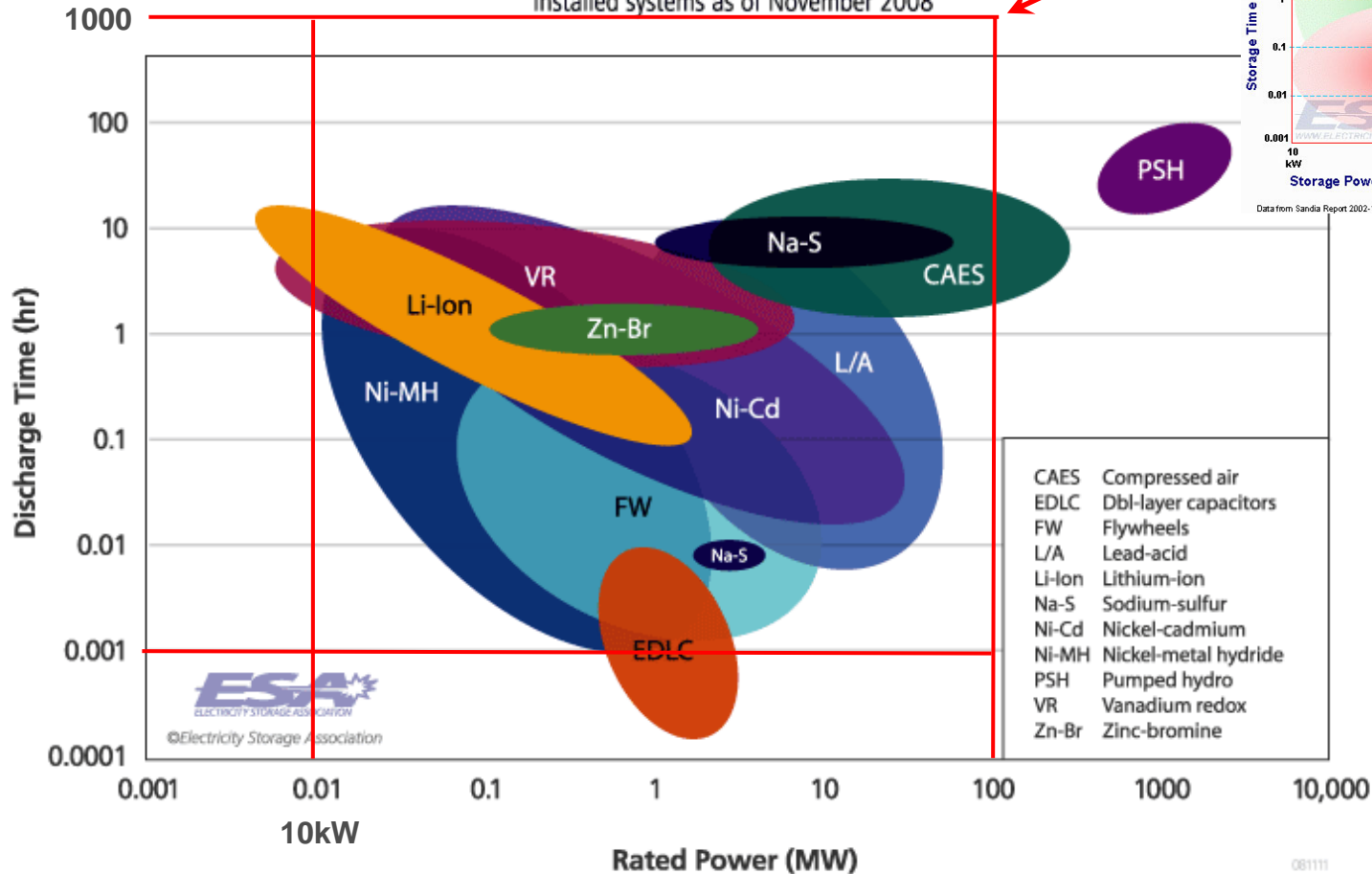

Data from Sandia Report 2002-1314

# High energy, High short circuit sources

(Grid Scale Energy Storage, XEVs, Light Rail)

## Fundamentals – XEVs

### XEVs in Many Flavors are Here and More are Coming

- **Hybrid Electric Vehicles:**

- 2011 Mercedes E Class Hybrid
- 2011 Porsche Cayenne S Hybrid
- 2011 Toyota Camry Hybrid
- 2011 Toyota Prius Hybrid
- 2011 Audi A8 Hybrid (likely introduction)
- 2011 BMW 5-Series ActiveHybrid
- 2011 Honda CR-Z sport hybrid coupe
- 2011 Lexus CT 200h Hybrid Hatchback
- 2011 Peugeot Diesel Hybrid\*
- 2011 Suzuki Kizashi Hybrid
- 2011 Audi Q5 Crossover Hybrid
- 2011 Hyundai Sonata Hybrid
- 2012 Infiniti M35 Hybrid
- 2014 Ferrari Hybrid

- **Battery Electric Vehicles:**

- 2010 Coda Automotive Sedan
- 2010 Mitsubishi iMiEV BEV
- 2010 Nissan LEAF
- 2010 Ford Battery Electric Van
- 2010 Tesla Roadster Sport EV
- 2011 Peugeot Urban EV\*
- 2011 Renault Kangoo Z.E.
- 2011 Renault Fluence Z.E.
- 2011 Tesla Model S
- 2011 BYD e6 Electric Vehicle
- 2011 Ford Focus
- 2011 Opel Ampera Extended Range BEV\*
- 2012 Fiat 500 minicar
- 2012 Renault City Car\*
- 2012 Renault Urban EV\*
- 2012 Audi e-tron
- 2013 Volkswagen E-Up\*
- 2016 Tesla EV

- **Extended Range Electric Vehicles:**

- 2010 Chevy Volt Extended Range EV

- **Plug-in Hybrid Vehicles:**

- Fisker Karma S Plug-in Hybrid
- 2010 Toyota Plug-in Hybrid
- 2011 BYD F3DM Plug-in Hybrid
- 2012 Toyota Prius Plug-in Hybrid
- 2012 Bright Automotive IDEA Plug-in Hybrid
- 2012 Ford Escape Plug-in Hybrid
- 2012 Volvo V70 Plug-in Hybrid\*
- 2013 BMW Vision

- **Fuel Cell Electric Vehicles:**

- Honda FCX Clarity
- GM Hydro-GEN3
- Chevy Equinox Fuel Cell
- Ford Fuel Cell EV
- 2012 Hyundai Tuscon ix35 Fuel Cell

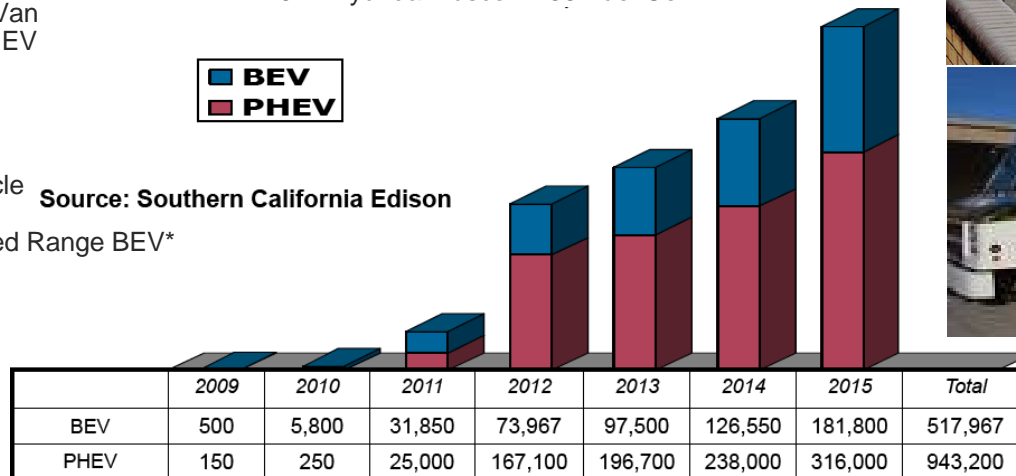

# High energy, High short circuit sources

(Grid Scale Energy Storage, XEVs, Light Rail)

## Fundamentals – XEVs

### XEVs – Growth in Power and Voltage

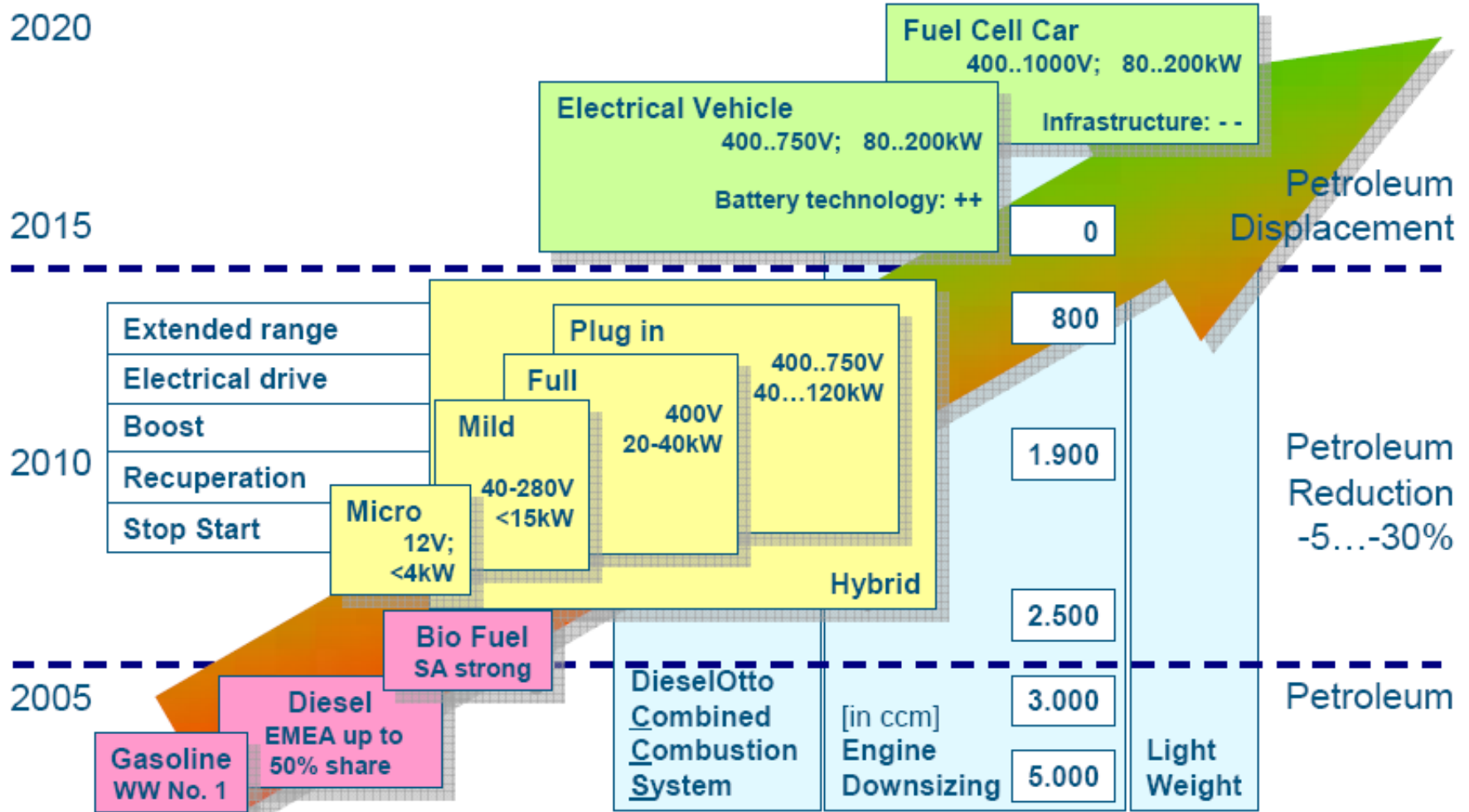

# High energy, High short circuit sources

(Grid Scale Energy Storage, XEVs, Light Rail)

## Fundamentals – XEVs

- Charging equipment (EVSE – Electric Vehicle Supply Equipment) has been defined by Industry standards bodies to safely provide the following service levels.

**DC QUICK  
CHARGE**



	<b>Voltage</b>	<b>Amperage</b>	<b>Time</b>
<b>Level 1</b>	120VAC	12A	8-12 hours
<b>Level 2</b>	240/208VAC	16-80A	4-6 hours
<b>DC Quick Charge</b>	<b>480VDC</b> (AC in / DC out)	<b>150 to 250A</b>	<b>15-30 min</b>  * Recharge battery to 80%

**Higher voltage reduces time to recharge battery**

# High energy, High short circuit sources

(Grid Scale Energy Storage, XEVs, Light Rail)

## Fundamentals – Light Rail

### Market Environment

- Growing market, particularly in Asia
- Competitors engrained in industry
- Reliance on government spending
- Regionalized sourcing/specification

### Technology

- Systems primarily 750 V DC
- DC contactors commonly used in on-board systems such as HVAC
  - Current requirements usually  $< 100A$
  - High shock/vibe, ring tongue terminals
- Trend toward AC traction drives



# High energy, High short circuit sources

(Grid Scale Energy Storage, XEVs, Light Rail)

## Fundamentals – Light Rail

### DC Applications

**Rapid Transit Vehicle**

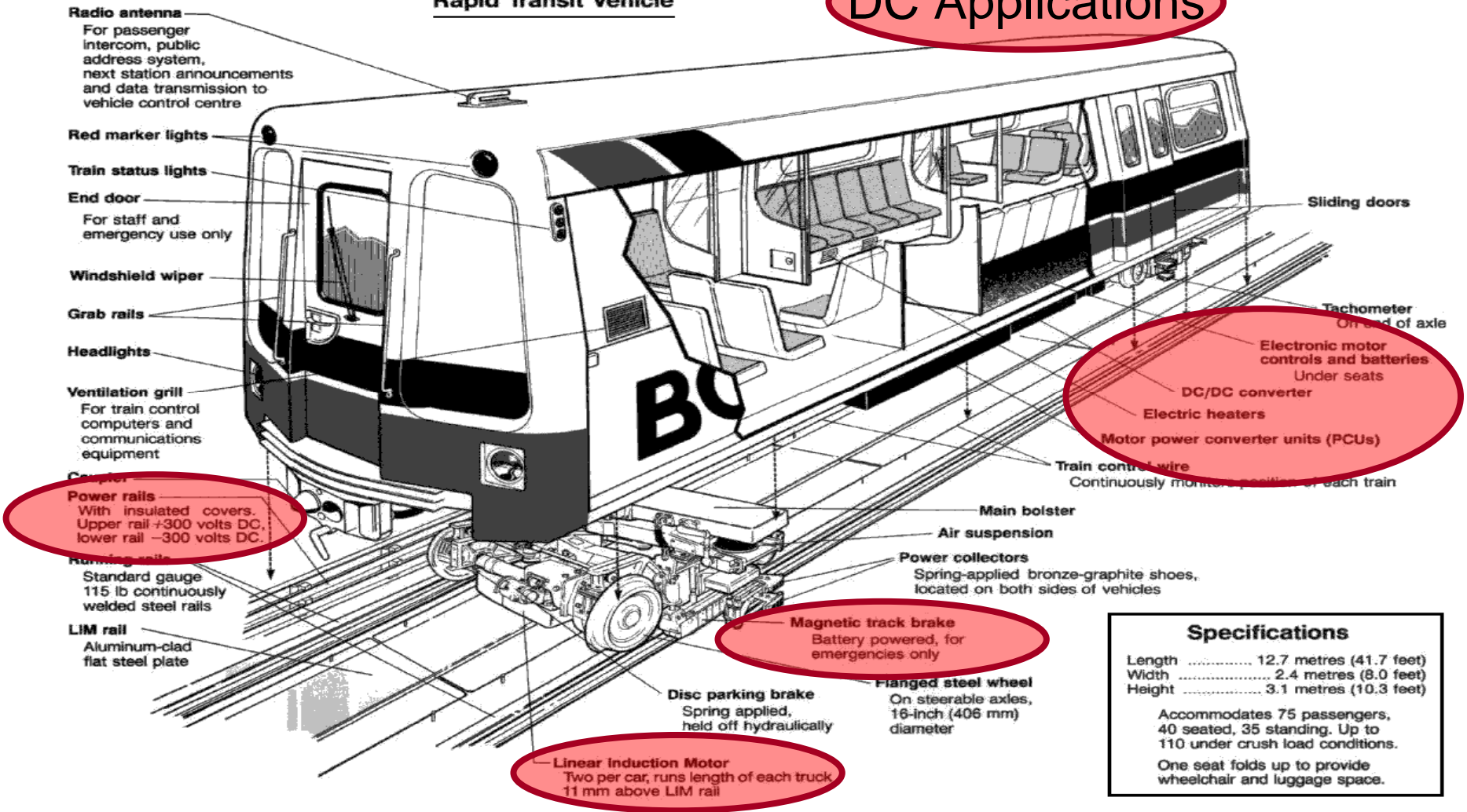

Specifications	
Length	12.7 metres (41.7 feet)
Width	2.4 metres (8.0 feet)
Height	3.1 metres (10.3 feet)
Accommodates 75 passengers, 40 seated, 35 standing. Up to 110 under crush load conditions.	
One seat folds up to provide wheelchair and luggage space.	

# High energy, High short circuit sources

(Grid Scale Energy Storage, XEVs, Light Rail)

## DC Switching Requirements

- Grid Scale Energy Storage
  - Voltage 300 to 800VDC
  - Current 200 to 1000A (100kW to 1MW)
  - Short Circuit 10X to 50X current
  - Inductance Low,  $\sim T = < 2\text{ms}$
- XEVs
  - Voltage 300 to 750VDC
  - Current 10 to 400A (3kW to 120kW)
  - Short Circuit 15X to 30X current
  - Inductance Low,  $\sim T = < 5\text{ms}$
- Light Rail
  - Voltage 750VDC
  - Current 10 to 200A
  - Short Circuit 10X to 100X
  - Inductance High,  $\sim T = 15\text{ms}$

		LiMn <sub>2</sub> O <sub>4</sub>	LiFePO <sub>4</sub>	LiNiMnCoO <sub>2</sub>
Capacity	[Ah]	5	4.5	30
Voltage	[V]	3.6	3.3	3.6
Short circuit (peak)	[A]	700	920	2000
Short circuit (cont.)	[A]	550	550	800

Source: CREATING A GREEN ADVANTAGE; 20 Jahre Fachgruppe Elektrische Kontakte Fachtagung ITG-Hardware-Technologie; 3. September 2010

# High energy, High short circuit sources

(Grid Scale Energy Storage, XEVs, Light Rail)

## Potential Technologies

- Today's Technologies
  - Fuses
  - Classic DC contactors/breakers
  - Gas filled DC relays
- Future Technologies needs
  - Increased reliability
  - Higher power ratings
  - Integrated safety
  - Containment of arc
  - Hybrid solid state

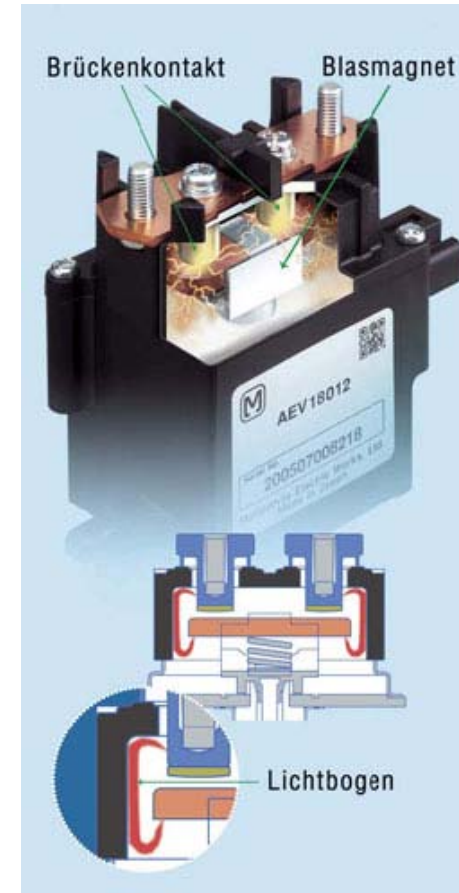

Source:- Panasonic/Matsushita website

# Presentation Outline

---

- DC Switching
- High Level Market Drivers
- Soft Sources
- High energy, High short circuit sources
- **Mixed source characteristics**

# Mixed source characteristics

(Microgrid, Data Centers, Nuclear)

## Fundamentals – Microgrid

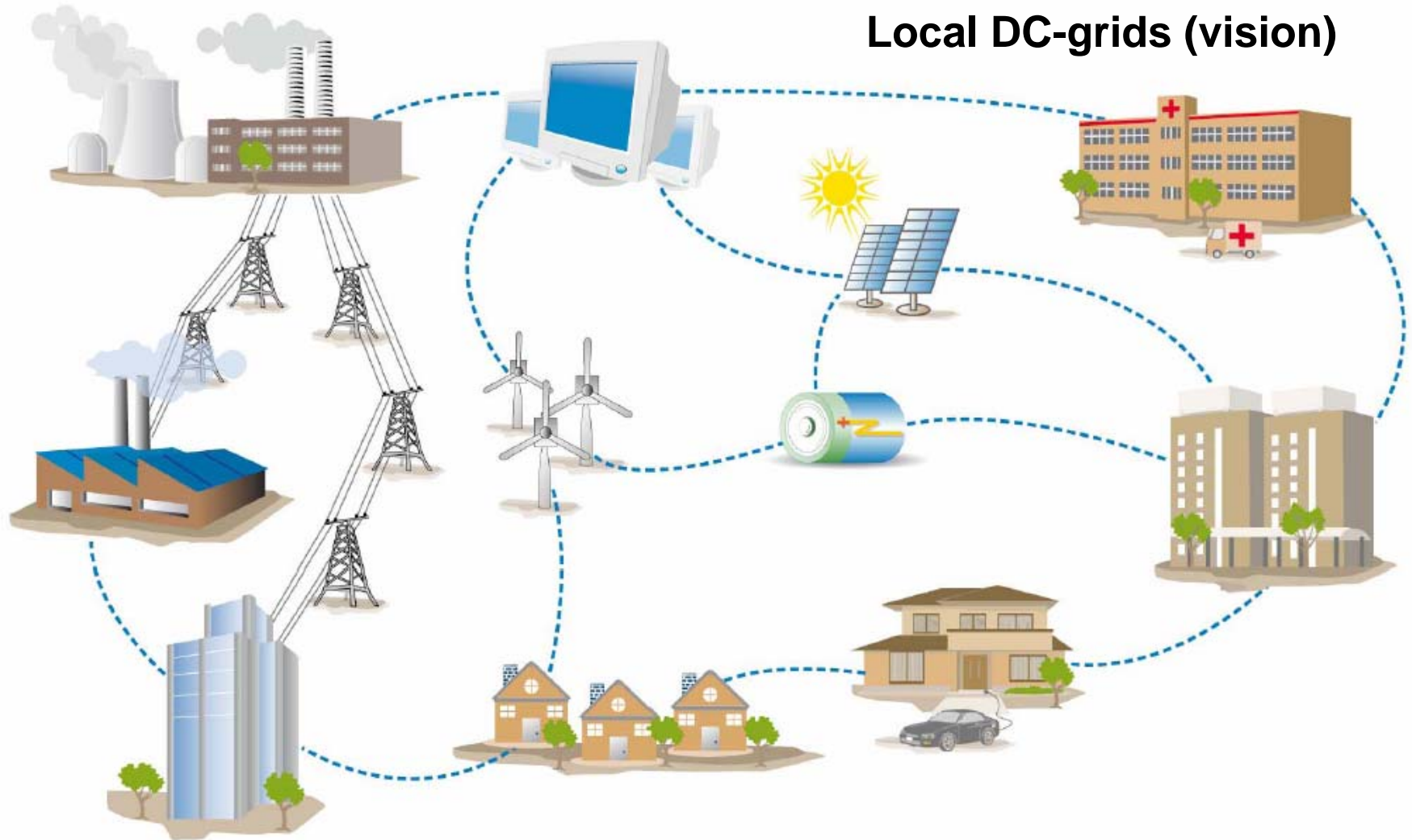

# Mixed source characteristics

(Microgrid, Data Centers, Nuclear)

## Fundamentals – Microgrid

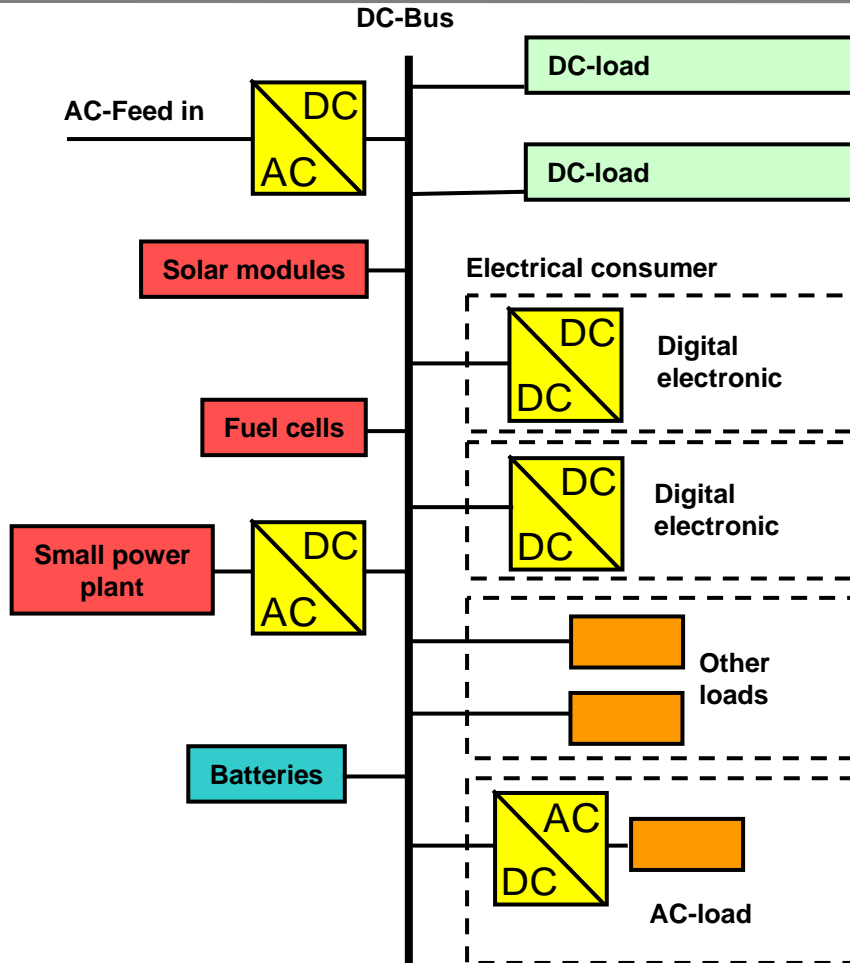

Participants in a DC network

### Local DC-grids (vision)

- Solar and fuel cell producing DC
  - Local and mobile (e-vehicle) batteries can only store DC
  - Many consumer like IT & multimedia-communication-products need DC
  - Every household or industrial product with power plug needs DC
- There are a lot of reasons to have a DC network
- Every DC producer and DC user has to be switched on and off

# Mixed source characteristics

(Microgrid, Data Centers, Nuclear)

## Fundamentals – Data Centers

### Total U.S. and world server electricity use (including cooling and auxiliary)

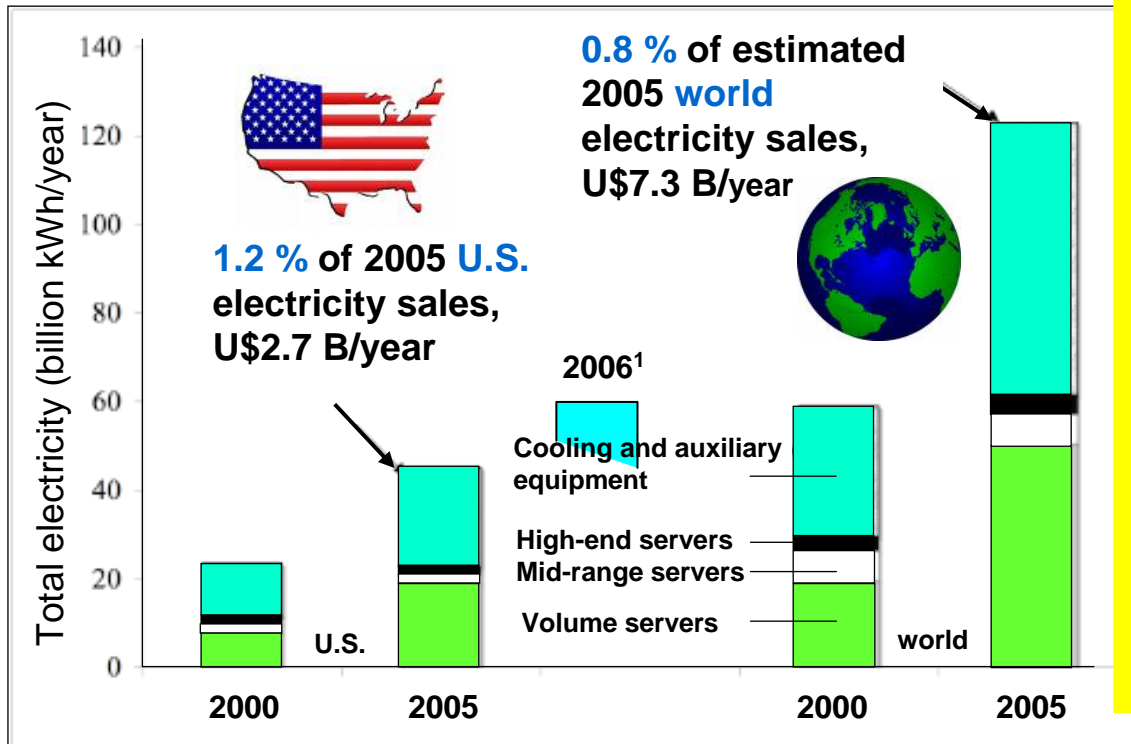

#### U.S. Data Centers

- 1.2% of U.S. Electricity
- 40-76% server growth 2005-2010
- **≈ 50% energy goes to cooling**
- 2011 goal of 10% overall U.S. data center energy savings<sup>1</sup> by 10.7 billion kWh

Source – Koomey Report Feb 15<sup>th</sup>, 2007, Presented at EPA Workshop Feb16<sup>th</sup>, 2007

<sup>1</sup>DOE—The Green Grid Goal for Energy Savings, 2008

# Mixed source characteristics

(Microgrid, Data Centers, Nuclear)

## Fundamentals – Data Centers

- Depending on architecture and control strategy, modern AC efficiency can be equal to or better than DC approaches



**TABLE 1. PUBLISHED EFFICIENCIES OF 480VAC AND 380VDC SYSTEMS.**

Author	408-208Vac Best Practice	380Vdc	Efficiency Improvement	References
LBNL DC system A vs. AC system B @ ~30% load	79%	87%	8%	1
LBNL DC system B vs. AC system B @ ~30% load	79%	85%	6%	1
Pratt @ 50% load	68%	74%	6%	4
Rasmussen @ 50% load	84%	88%	4%	5
The start and end points of the power path vary between each study, which is the major reason for the variation in efficiencies.				

Source: The green grid peer review of “DC Power for improved data center efficiency” by Lawrence Berkeley national laboratory; 2007

# Mixed source characteristics

(Microgrid, Data Centers, Nuclear)

## Fundamentals – Nuclear

- **Nuclear DC applications**

- DC motor control centers and switchboards to provide power from UPS / battery backup
- Critical turbine lubrication
- Reactor coolant pumping and valving
- Sensing and monitoring

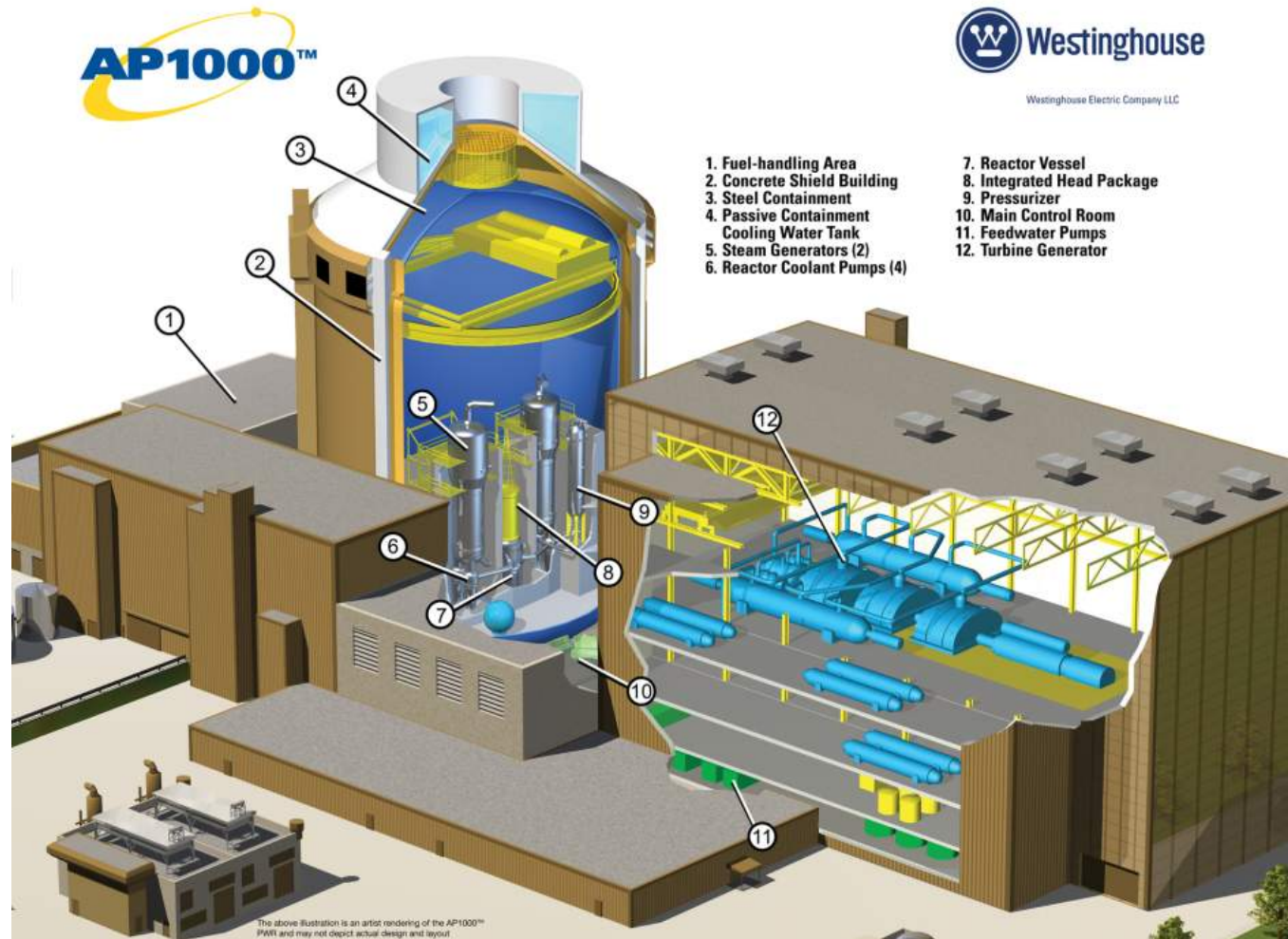

# Mixed source characteristics

(Microgrid, Data Centers, Nuclear)

## Fundamentals – Nuclear

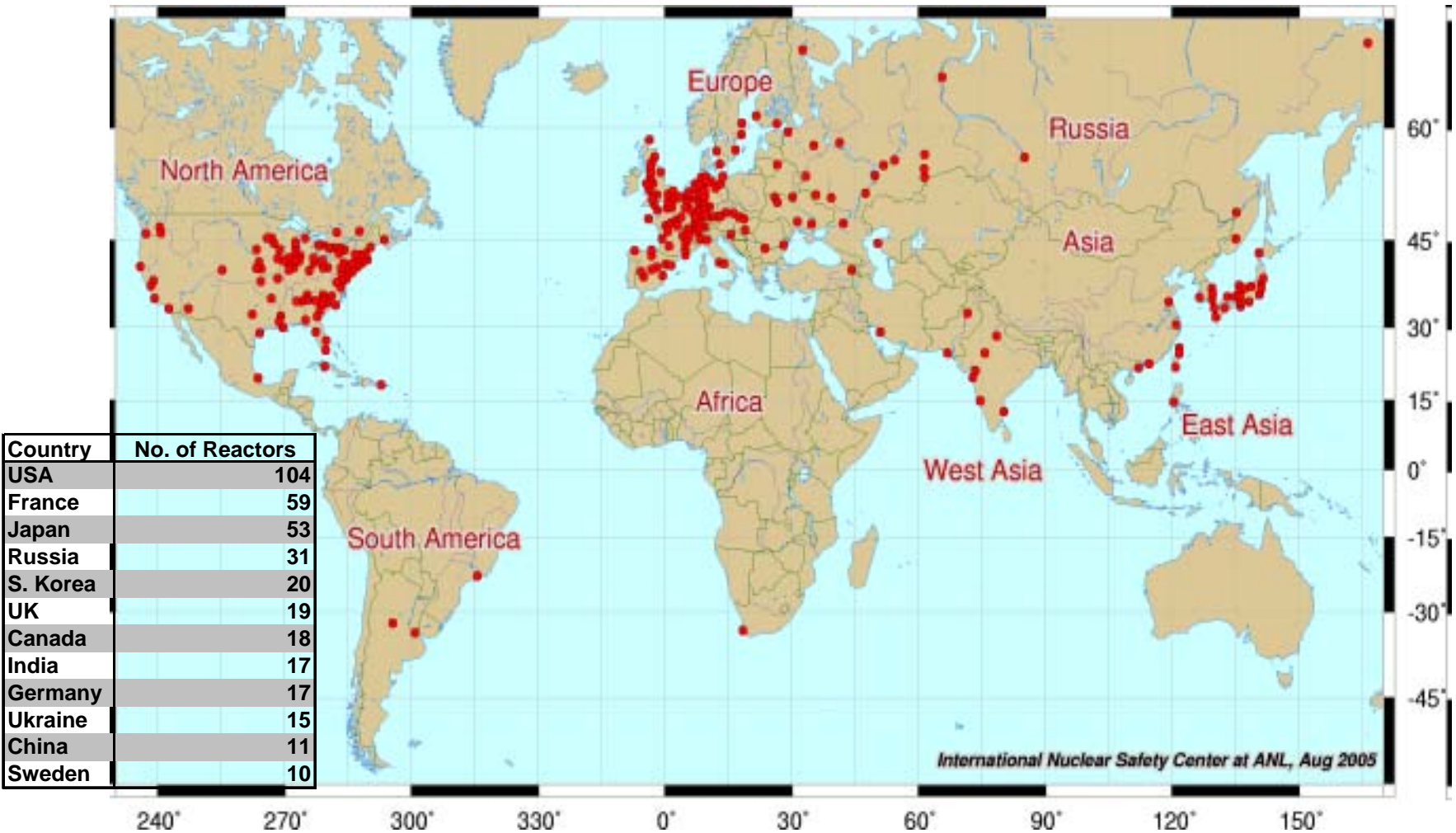

Data Source: World Nuclear Association

# Mixed source characteristics

(Microgrid, Data Centers, Nuclear)

## Fundamentals – Nuclear



**World Nuclear market to grow by 94%**

**Reactors Operating 436**

**Reactors Under Construction 43**

**Reactors Planned 106**

**Reactors Proposed 266**

Country
USA
France
Japan
Russia
S. Korea
UK
Canada
India
Germany
Ukraine
China
Sweden

11  
10

*International Nuclear Safety Center at ANL, Aug 2005*

240° 270° 300° 330° 0° 30° 60° 90° 120° 150°

# Mixed source characteristics

(Microgrid, Data Centers, Nuclear)

## DC Switching Requirements

---

- Voltage
  - 300 to 900VDC
    - Driven by power conversion specifications and standards
- Current
  - 10 to 1000A and higher
    - Most applications are power distribution
- Short Circuit
  - 2X to 30X current
    - Inverter sources vs. energy storage sources
- Inductance
  - $T = 2\text{ms to } 15\text{ms}$ 
    - Varied load and source characteristics

# Mixed source characteristics

(Microgrid, Data Centers, Nuclear)

## Potential Technologies

- Today's Technologies
  - Fuses
  - Classic DC contactors/breakers
  - Repurposed AC products
- Future Technologies needs
  - DC power distribution product families
  - DC power control products families
  - Cost
  - Increased reliability
  - Higher power ratings
  - Integrated safety
  - Solid state and Hybrid solid state
  - Power conversion as control and protection



# Observations – Markets

Viable large scale energy storage and/or distributed generation will radically change utility operations

XEVs will happen, Safe DC solutions will continue to evolve for this growing volume market

As solar PV grows, increased safety scrutiny will change the nature of the protection products required

# Observations – Products

Many DC applications are served with 50 year old designs

Many DC applications are served by repurposed AC products

The markets and opportunities exist that can drive a DC Switching Renaissance

Emerging markets are small; driving focus on low capital cost innovations



Thank you very much for your kind attention

Peter Theisen

[peterjtheisen@eaton.com](mailto:peterjtheisen@eaton.com)