

## **OPERATION RESULTS OF THE KSTAR HELIUM REFRIGERATION SYSTEM**

H.- S. Chang<sup>1</sup>, E. Fauve<sup>2</sup>, D.-S. Park<sup>1</sup>, J.-J. Joo<sup>1</sup>, K.-M. Moon<sup>1</sup>, K.-W. Cho<sup>1</sup>, H. K. Na<sup>1</sup>, M. Kwon<sup>1</sup>, S.-H. Yang<sup>3</sup>, and G. Gistau-Baguer<sup>4</sup>

<sup>1</sup>National Fusion Research Center  
Daejeon, 305-333, Korea

<sup>2</sup> Air Liquide – Advanced Technologies Division  
Sassenage, 38360, France

<sup>3</sup>Cryogenic Engineering Inc.  
Goyang, 411-718, Korea

<sup>4</sup>Consultant  
Biviers, 38330, France

### **ABSTRACT**

The “first plasma” (100 kA of controllable plasma current for 100 ms) of KSTAR has been successfully generated in July 2008. The major outstanding feature of KSTAR compared to most other Tokamaks is that all the magnet coils are superconducting (SC), which enables higher plasma current values for a longer time duration when the nominal operation status has been reached. However, to establish the operating condition for the SC coils, other cold components, such as thermal shields, coil-supporting structures, SC bus-lines, and current leads also must be maintained at proper cryogenic temperature levels. A helium refrigeration system (HRS) with an exergetic equivalent cooling power of 9 kW at 4.5 K has been installed for such purposes and successfully commissioned.

In this proceeding, we will report on the operation results of the HRS during the first plasma campaign of KSTAR. Using the HRS, the 300-ton cold mass of KSTAR was cooled down from ambient to the operating temperature levels of each cold component. Stable and steady cryogenic conditions, proper for the generation of the “first plasma” have been maintained for three months, after which, all of the cold mass was warmed up again to ambient temperature.

**KEYWORDS:** Fusion, Tokamak, superconducting magnets, helium refrigeration, supercritical helium, liquid helium.

## **INTRODUCTION**

After successful commissioning [1], the first task for the HRS was the conditioning of the contaminated cooling channels of the KSTAR cold components to prepare for the cool down and consequent first plasma campaign of KSTAR. The conditioning activities had been accomplished within one week, after which, the cool down of KSTAR was initiated. The cool down itself, which took about 21 days, had been declared to be achieved when the temperature of the return gaseous helium (GHe) collected from the KSTAR cold components reached about 5 K. After turning on the cold GHe compressor and the two supercritical helium (SHe) circulators in order to supply the SC magnets with large SHe mass flow rate values at 4.3 K proper for current charging, the cryogenic conditions for plasma experiments were fulfilled. Except for a major trip, which stopped the whole HRS and required two days for full recovery, such conditions had been maintained for three months in a very stable and steady-state manner. The warm up of KSTAR, which completed the operation cycle of the HRS, took about 14 days and was considered as finished when the GHe temperatures collected from KSTAR were close to 250 K.

## **CONDITIONING, COOL DOWN, AND WARM UP OF KSTAR**

### **Conditioning**

Before starting the cool down, the helium cooling channels of the KSTAR cold components must be conditioned free of any impurities such as air, water, and solvents. Impurities solidify during cool down and later become potential risk factors which can damage the cryogenic turbo-rotating machines (turbines, cold GHe compressor, SHe circulators) and/or clog the tiny helium paths of the cable-in-conduit conductors (CICC) the SC magnet coils and bus-lines (BL) consist of.

The conditioning activities had been performed in two phases. First conventional pumping and (GHe) filling had been applied to all cooling channels three times (or more if necessary) until the dew-point of the last filled GHe was less than  $-65\text{ }^{\circ}\text{C}$ . The results varied between  $-71\text{ }^{\circ}\text{C}$  and  $-85\text{ }^{\circ}\text{C}$ . Then, in the case of cooling channels which consist of CICC, such as SC coils and BL, GHe with a maximum mass flow rate of 90 g/s at 18.5 bars ( $1\text{ bar}=10^5\text{ Pa}$ ) had been flushed across and its impurities analyzed. Flushing was stopped when the  $\text{N}_2$  and  $\text{H}_2\text{O}$  concentrations in the GHe downstream the CICC cooling channels indicated less than 5 ppm.

### **Cool Down and Warm Up**

The cool down of KSTAR was launched after completion of the conditioning works. The temperature of the GHe dedicated for cool down had been adjusted by mixing different temperature levels from the high pressure (HP) GHe stream of the cold box (C/B) and manipulating the cooling power of the expansion turbines. The GHe collected after passing the cooling channels joined the low pressure (LP) return C/B stream, also at different temperature levels in order to keep the C/B temperature distribution as balanced as possible. The SC magnets and BL are implemented with GHe supply/return lines exclusively assigned for cool down and warm up only whereas the thermal shields (TS) and current leads (CL) use the same lines as during normal operation. Special care had been taken during cool down such that the temperature difference between the supply and return GHe did not exceed 50 K and the speed of cool down was not faster than  $-1\text{ K/hr}$ .

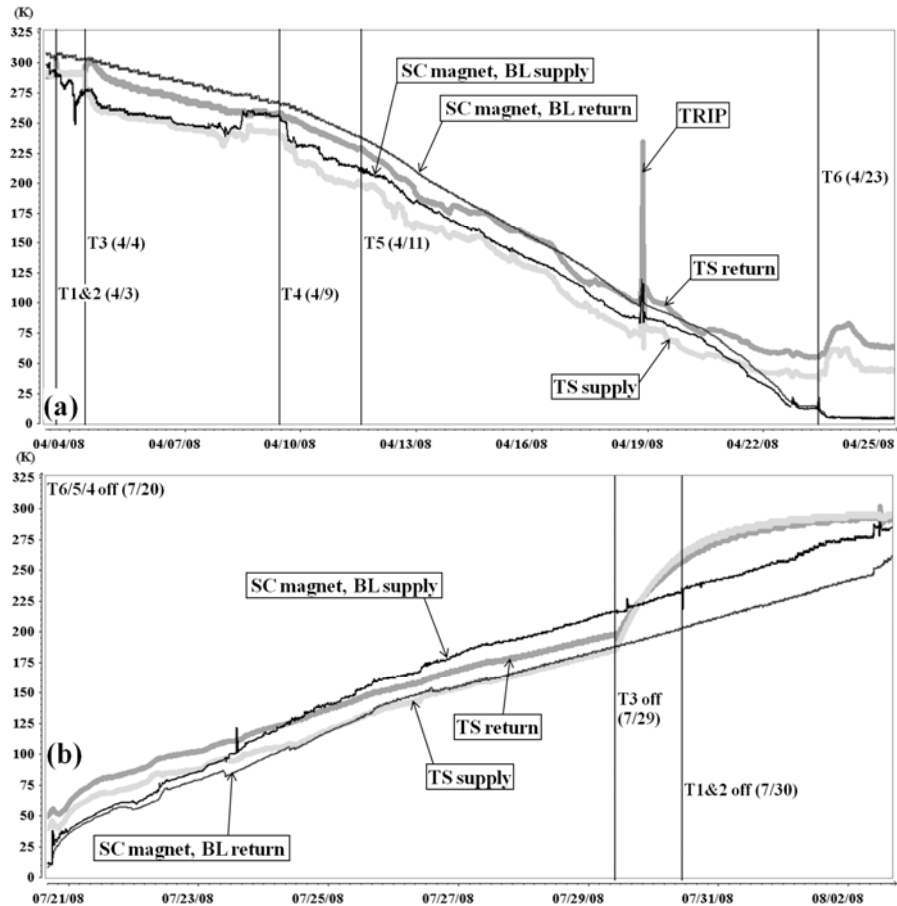

**FIGURE 1.** (a) Cool down and (b) warm up curve of the KSTAR cold components.

FIGURE 1(a) shows the temperature evolution of the supply/return GHe during the cool down period. Depending on the minimum GHe temperature required, turbines had been turned on one by one, and the C/B was cooled down along with KSTAR. The temperature difference between the supply and return GHe had been kept below 40 K and the average cool down speed was  $-0.63$  K/hr. A trip which stopped the whole HRS occurred due to a failure of the main power supply when the supply GHe temperature was about 100 K. However, since it was far from liquid helium (LHe) production, the full recovery took only 2 hours after recognizing the cause of the trip.

The warm up of KSTAR used the same GHe supply/return strategy as during cool down, except that the supply GHe temperature was increased with time (on the average by  $+0.73$  K/hr). As shown in FIGURE 1(b) the GHe supply to the TS had been terminated when the return temperature was about 200 K. The HRS, and therefore the whole warm up, was stopped when the GHe temperatures collected from the magnets and bus-lines reached 250 K.

## STEADY STATE OPERATION OF THE HRS

During the plasma experiments, for all plants and facilities related to the operation of the KSTAR Tokamak, utmost priority was given to safety and stability. For the sake of operational stability, the HRS had been operated with a cooling capacity much larger than necessary despite higher power consumption and therefore increased operation expenses.

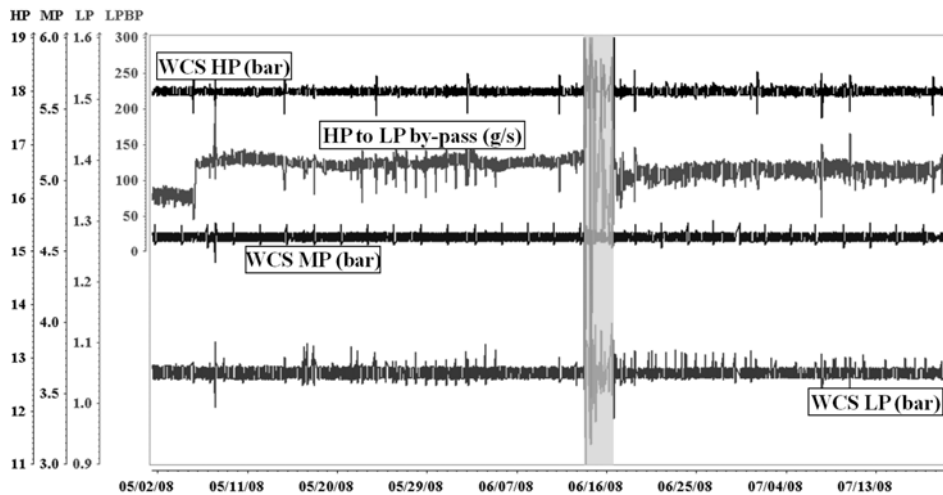

**FIGURE 2.** Operation results of the WCS during the plasma experimental period. Shaded region designate the major TRIP and following recovery term (applies to all figures hereafter).

### Warm Compression System

The warm compression system (WCS), which compresses the GHe to be expanded in the C/B via turbines in order to generate the “COLD” and collects all evaporated LHe used for cooling, plays the major role in the stable operation of the HRS. As shown in FIGURE 2, the three pressure levels of the WCS had been maintained with only 1~3 % deviation for three months. The by-pass GHe mass flow rate from HP to LP cycle (LPBP) indicates the overcapacity and therefore the operational margin of the WCS. From the viewpoint of the WCS alone, the LPBP mass flow rate, which was almost always kept higher than 100 g/s, corresponds to the excess LHe evaporation (equivalent to 2 kW extra heat load at 4.5 K) that can be handled by the WCS.

The major trip and following recovery period highlighted on FIGURE 2 (shaded region) was related to the breakdown of one of the oil pumps. The loss of oil pressure caused the WCS to trip and consequently the trip of the entire HRS. The WCS was equipped with redundant oil pumps allowing quick restart of the system. Nevertheless, two days were required to return KSTAR to normal operating conditions.

### Cold Box

The C/B of the KSTAR HRS is equipped with 6 oil-free static GHe bearing expansion turbines. The C/B is designed to produce an exergetic equivalent cooling power of 9 kW at 4.5 K via quasi-isentropic expansion of the turbines without liquid nitrogen pre-cooling. The turbines were operated fully automatically. The only accessible parameter is their rotational speed which is a result of changing the inlet pressure and consequently processed mass flow rate. Variation of the rotational speed of each turbine had been performed according to attenuation logics related to their stability and safety. Attenuators linked to the level of the LHe storage directly controlled the capacity of the C/B.

A three month trend of the rotational speed of the 6 turbines is shown in FIGURE 3. Except for turbine T1, the curves are rising with time which cause is suspected to be some moisture accumulation on the first heat exchanger (HX) block inside the C/B. Periodic peaks in the speed curves occurred whenever one of the double bed 80 K or single bed 20 K adsorbers inside the C/B were regenerated. The turbines were operated at 78~93 % of their maximum rotational speed values which correspond to 48~79 % of the maximum

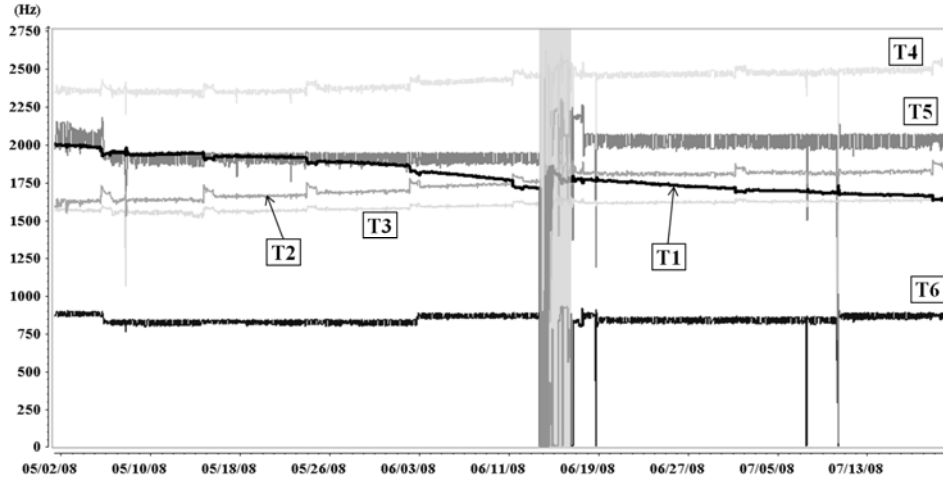

**FIGURE 3.** Rotational speed curves of the six turbines T1~T6 during the plasma experimental period.

**TABLE 1.** Suction/discharge helium parameters, and related isentropic efficiency of the turbines T1~T6 (measured on 18<sup>th</sup> July, 2008). For \* and \*\* refer to corresponding parts in the text.

	<b>T1</b>	<b>T2</b>	<b>T3</b>	<b>T4</b>	<b>T5</b>	<b>T6</b>
$P_{in}$ (bar)	17.69	10.97	13.48	17.57	14.27	15.39
$P_{out}$ (bar)	12.56	4.83	4.81	4.83	1.21	2.94
$T_{in}$ (K)	195.06	123.92	73.48	48.8	27.8	8.5
$T_{out}$ (K)	177.6	98.33	52.28	37.62	14.66	5.55
Efficiency	0.70	0.74	**0.86	*0.57	0.74	**0.96

cooling capacity. TABLE 1 shows the isentropic efficiencies from the data extracted on 18<sup>th</sup> of July, 2008. As already mentioned elsewhere [1], turbine T4 was operated at off-design operating conditions, resulting in a rather low efficiency (\*of Table 1), whereas the unusual high efficiency of T3 could be accounted to the uncertainty of the temperature measurements and has almost obviously the same reason in the case of T6 (\*\*of Table 1).

By using empirical formulae [2] to get the mass flow rates across the turbines and calculating the enthalpy balance at the cold end of the C/B, the isothermal cooling capacity of the C/B turns out to be about 5~5.5 kW at 4.3 K (temperature of the LHe inside the thermal damper where isothermal cooling takes place) during the plasma experimental period.

## Distribution Box

The distribution box (D/B) converts the cryogenic helium (LHe, SHe, GHe) produced in the C/B into a state proper for cooling the KSTAR cold components by modifying the pressure, mass flow rate, and temperature. Since the cooling of the TS, SC BL, and CL are rather straightforward and mainly consist of supply and return of cryogenes, this section will focus on the cooling of the SC magnets during the KSTAR plasma experiments.

A schematic cooling scheme of the KSTAR Tokamak from the viewpoint of the D/B is shown in FIGURE 4. GHe (15.8 bar, 42~52 K, 190~220 g/s) was supplied directly from the C/B to the TS and after cooling (14 bar, 52~67 K) returned back to the C/B cycle. The CL were supplied with LHe (4.54 K, 1.35 bar, 5 g/s) from the LHe storage which was heated up to ambient temperature and discharged to the LP cycle of the WCS. These non-isothermal cooling schemes of the TS and CL used on the average an exergetic equivalent

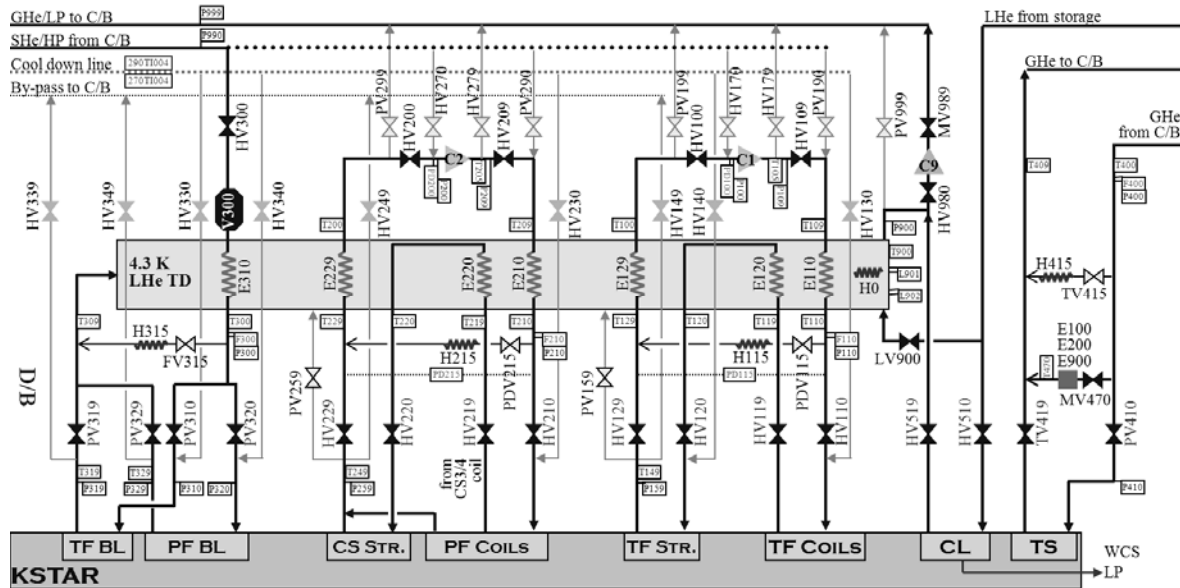
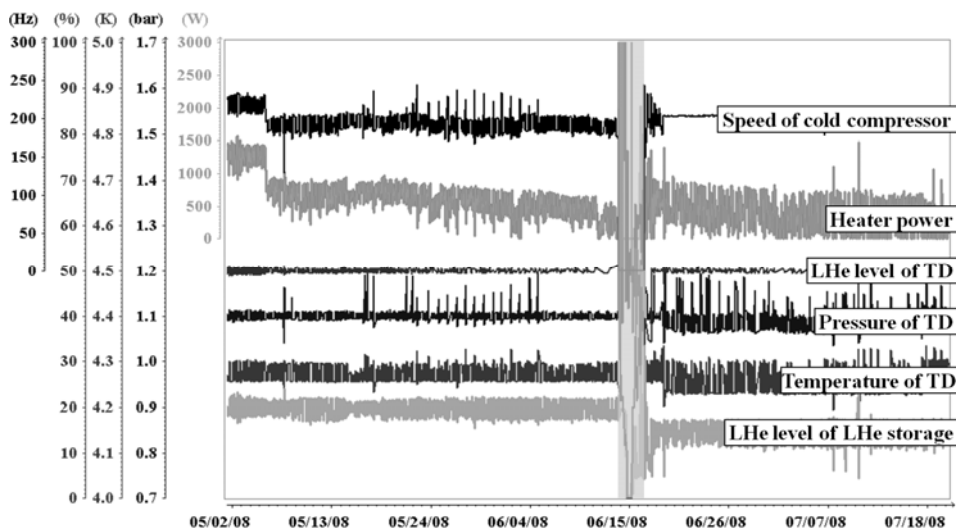

**FIGURE 4.** Cooling scheme of KSTAR. Thick lines designate the helium flow during normal operation.

cooling power of 0.9~1.3 kW and 0.5 kW at 4.5 K, respectively. Considering the isothermal cooling capacity, the C/B had been operated on the average at about 7 kW at 4.5 K exergetic equivalent during the KSTAR plasma experimental period.

The SC BL were supplied with SHe (7 bar, 5~5.5 K, 40~50 g/s) issued from the C/B which was cooled down to 4.4 K via a HX immersed in the LHe of the so called thermal damper (TD) and its pressure reduced down to 3.5 bar by cryogenic valves. The depressurized and heated SHe (>3 bar, ~5 K) discharged from the SC BL was expanded into the TD at 1.1 bar.

The TD is a vessel with a volume of 6 m<sup>3</sup> where LHe supplied from the LHe storage is accumulated and vaporized by heat loads generated during the cooling of the SC magnets and BL. FIGURE 5 shows the operation results of the TD during the KSTAR plasma experiments. The temperature of the LHe inside the TD was maintained close to 4.3 K by operating the cold GHe compressor (C9 of FIGURE 4) at 180~220 Hz and thereby



**FIGURE 5.** Operation results of the TD during the plasma experimental period of KSTAR.

keeping the vapor pressure close to 1.1 bar. The LHe level of the TD was controlled at 50 % by the LHe supply valve. On the other hand the LHe level of the LHe storage was controlled at 15~20 % by two heaters immersed in the LHe of the TD. The heaters were also linked to the attenuation logic of the WCS LP cycle pressure to reduce their values in case of excess return cold GHe flow due to increased heat load from KSTAR. The large fluctuations of the heater values were mainly due to the LHe supply variation to the CL.

To cool the toroidal field (TF) and poloidal field (PF) SC magnets of KSTAR, two closed-loop SHe circuits each with one SHe circulator and three HX's immersed in the LHe of the TD have been set up. The SHe was pressurized from 4.2 bar to 6.5~6.9 bar by the SHe circulators (C1 and C2 of FIGURE 4, respectively) and issued to the serially connected cooling channels of the magnet coils and structures. After pressurization by the circulators and discharge from the magnet coils or structures, the heated SHe was cooled via the HX's (E110/210 and E120/220 or E129/229 of FIGURE 4, respectively) down to 4.4 K. The operation results of the magnet cooling circuits are shown in FIGURE 6. The rotational speed of the circulators, therefore the SHe mass flow rate and pressure head were

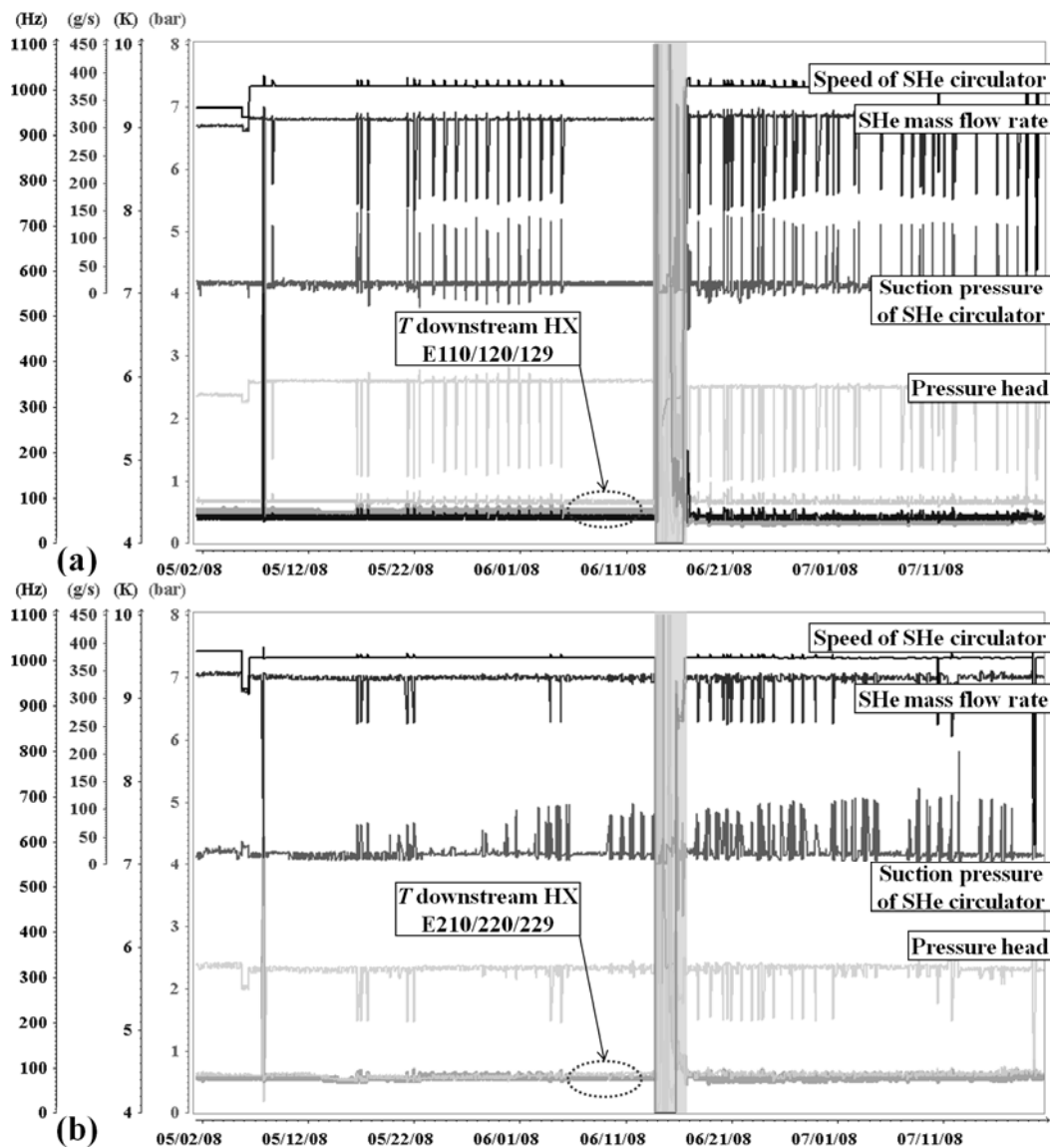

**FIGURE 6.** SHe and circulator parameters during the plasma experimental period in case of the (a) TF and (b) PF magnet cooling circuit.

held at constant values. Thanks to the effective cooling of the thermo-siphon type LHe/SHe HX's, the temperature values downstream those HX's were always close to 4.4 K, within the measurement accuracy of the temperature sensors ( $\pm 0.1$  K). Since the magnet coils were only partially charged (TF: 15 kA, PF: 4 kA maximum) compared to design values (TF: 35 kA, PF: 21 kA maximum) all the SHe and circulator parameters were almost always very stable.

In the case of the TF magnet circuit in FIGURE 6(a), rather periodic fluctuations of the SHe and circulator parameters can be observed. They result from some heat in-leak accumulation due to a too short connection of a pressure safety valve (PSV) with the SHe process line on the secondary distribution box (D/B #2). Since the return SHe lines of the TF and PF magnets are thermally connected to form a 5 K shield inside the cryogenic transfer lines between KSTAR and the D/B, depending on the amount of the heat in-leak, similar fluctuations, distinguished by large drops in the mass flow rate, can be observed in the PF circuit in FIGURE 6(b). However, by cooling the PSV connection point with SHe periodically, it was possible to make the fluctuations happen only when all the magnet coils were discharged during the night shift. Small fluctuations in the PF circuit were due to the fast charging and discharging of the magnet coils and never had visible effects on the TF circuit. Anyway, all those fluctuations scarcely affected the SHe temperature downstream the HX's and it was always possible to maintain a safe and steady state cryogenic operating condition for the SC magnets during the plasma experimental period of KSTAR.

## CONCLUSION

By operating the HRS, the cryogenic conditions proper for charging the SC magnet coils and generating the first plasma of the KSTAR Tokamak had been maintained for three months in a very stable and steady-state manner. Previous commissioning results [1] and cooling capacity margins observed during the first plasma campaign strongly indicate the capability of the HRS to cope with the future 2 MA-plasma-current scenario of KSTAR [3].

## ACKNOWLEDGEMENTS

This work was supported by the Ministry of Education, Science and Technology under the KSTAR Project.

## REFERENCES

1. Chang, H.-S. *et al.*, *Proceedings of the 22<sup>nd</sup> ICEC and ICMC Conference 2008*, pp. 675-680 (2009).
2. Fauve, E., "Functional Analysis of the Cold Box", KSTAR HRS Project Documentation, March 2008.
3. Alekseev A. *et al.*, "Thermo-Hydraulic Analysis of the KSTAR Magnet System", KSTAR Project Internal Release Documentation, December 2002.