

CERN Press Release: Analysis of LHC Incident

Geneva, 16 October 2008 (HE26). Investigations at CERN following a large helium leak into sector 3-4 of the Large Hadron Collider (LHC) tunnel have confirmed that cause of the incident was a faulty electrical connection between two of the accelerator's magnets. This resulted in mechanical damage and release of helium from the magnet cold mass into the tunnel.

Proper safety procedures were in force, the safety systems performed as expected, and no one was put at risk. Sufficient spare components are in hand to ensure that the LHC is able to restart in 2009, and measures to prevent a similar incident in the future are being put in place.

"This incident was unforeseen," said CERN Director General Robert Aymar, *"but I am now confident that we can make the necessary repairs, ensure that a similar incident can not happen in the future and move forward to achieving our research objectives."*

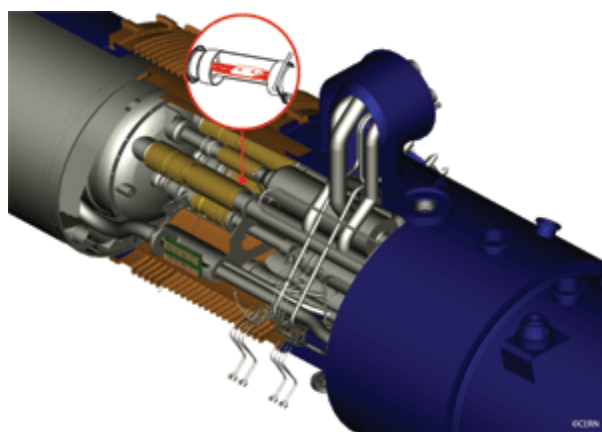

Fig. 1. Investigations have shown that a faulty electrical connection between two magnets (shown in red) was the cause of the incident in sector 3-4 of the LHC on 19 September, 2008.

The summary report follows.

Summary of the Analysis of the 19 September 2008 Incident at the LHC

On 19 September 2008, during powering tests of the main dipole circuit in Sector 3-4 of the LHC, a fault occurred in the electrical bus connection in the region between a dipole and a quadrupole, resulting in mechanical damage and release of helium from the magnet cold mass into the tunnel. Proper safety procedures were in force, the safety systems performed as expected, and no-one was put at risk.

After a period during which the temperature of the magnets in question was allowed to rise close to room temperature, inspections started and a number of clear findings have now been established. Investigations are continuing and the complete findings will be reported at a later date.

A - In the following summary, a brief description is given of the chain of events which occurred around mid-day on 19th September. A more detailed technical report is available [here](#).

1. During the ramping-up of current in the main dipole circuit at the nominal rate of 10 A/s, a resistive zone developed leading in less than one second to a resistive voltage of 1 V at 9 kA. The power supply, unable to maintain the current ramp, tripped off, and the energy discharge switch opened, inserting dump resistors into the circuit to produce a fast current decrease. In this sequence of events, the quench detection, power converter and energy discharge systems behaved as expected. Prior to this fast discharge, it is certain that a magnet quench can be excluded as the cause of the initial event. During the discharge, many magnet quenches were triggered automatically in the arc and the helium from their cold masses was recovered through the self actuated relief valves.

2. Within one second, an electrical arc developed, puncturing the helium enclosure and leading to a release of helium into the insulation vacuum of the cryostat. After 3 and 4 seconds, the beam vacuum also degraded in beam pipes 2 and 1, respectively. Then the insulation vacuum started to degrade in the two neighbouring subsectors*.

3. The spring-loaded relief discs on the vacuum enclosure opened when the pressure exceeded atmospheric, thus releasing helium into the tunnel, but they were unable to contain the pressure rise below the nominal 0.15 MPa in the vacuum enclosure of the central subsector, thus resulting in large pressure forces acting on the vacuum barriers separating the central subsector from the neighbouring subsectors.

B - After restoring power and services in the tunnel and ensuring mechanical stability of the magnets, the investigation teams proceeded to open up the cryostat sleeves in the interconnections between magnets, starting from the central subsector. This confirmed the location of the electrical arc, showed absence of electrical and mechanical damage in neighbouring interconnections, but revealed contamination by soot-like dust which propagated over some distance in the beam pipes. It also showed damage to the multilayer insulation blankets of the cryostats. The forces on the vacuum barriers attached to the quadrupoles at the subsector ends were such that the cryostats housing these quadrupoles broke their anchors in the concrete floor of the tunnel and were moved away from their original positions, with the electric and fluid connections pulling the dipole cold masses in the subsector from the cold internal supports inside their undisplaced cryostats. The displacement of the quadrupoles cryostats damaged "jumper" connections to the cryogenic distribution line, but without rupturing its insulation vacuum.

C - Pending further inspection of the inside of the dipole cryostats, it has been established that the number of magnets to be repaired is at most 5 quadrupoles and 24 dipoles from the three subsectors involved. But it is possible that more magnets will have to be removed from the tunnel for cleaning and exchange of multilayer insulation. Spare magnets and spare components appear to be available in adequate types and sufficient quantities to allow replacement of the damaged ones during the forthcoming shutdown. The extent of contamination to the beam vacuum pipes is not yet fully mapped, but is known to be limited; in situ cleaning is being considered to keep the number of magnets to be removed to a minimum. The plan for

removal/reinstallation, transport and repair of magnets in Sector 3-4 is being established and integrated with the maintenance and consolidation work to be performed during the winter shutdown across the whole CERN facility. The corresponding manpower resources have been secured.

D - Once all possible inspections are completed, an analysis of the events will lead to recommendations for future actions to prevent the reoccurrence of this type of initial event, and to mitigate its consequences should it accidentally reoccur. Although the cause of the initial growth of connection resistance has not yet been established, and knowing that a similar event has not occurred in the test of all other sectors and of their thousands of connections, it has nonetheless been decided that additional measurements to generate early warnings and interlocks, improvements in pressure relief devices and in external anchoring of the quadrupole cryostats with vacuum barrier will be implemented before any further powering of the LHC circuits at high current.

Technical Appendix: LHC Design

* The arcs of the LHC, extending over most of the length of each 3.3 km long sector, are composed of a periodic lattice, the elementary cell of which (107 m long) is composed of a horizontally focusing quadrupole, three dipoles, a vertically focusing quadrupole and another three dipoles. In each family, the magnets are electrically powered in series throughout the sector. The magnets, equipped with their helium vessel and end covers, constitute the "cold masses", which, in normal operation, contain superfluid helium at 1.9 K and 0.13 MPa, and are thermally insulated from the vacuum enclosure. The neighbouring cold masses are electrically and hydraulically interconnected. The weight of the cold mass is transmitted to the vacuum enclosure via cold support posts and is further transmitted to the tunnel floor by adjustable support jacks, anchored in the concrete. The lattice cell corresponds to the extent of the local cooling loops of the cryogenic system, fed from the cryogenic distribution line through a "jumper" connection every 107 m at the location of a quadrupole. Two subsequent cells constitute a vacuum subsector sharing a common insulation vacuum; the insulation vacuum enclosures of neighbouring subsectors are separated by "vacuum barriers". The two beam pipes constitute two other separate vacuum systems, extending over the whole length of the continuous cryostat, and segmented at the arc ends.