

THz Generation Using Fluxon Dynamics in High Temperature Superconductors

N. F. Pedersen and S. Madsen

Abstract—We consider THz emission due to fluxon dynamics in a stack of inductively coupled long Josephson junctions connected electrically to a resonant cavity. By comparing to experiments on Josephson junction parametric amplifiers we consider the role of a negative resistance in connection with THz emission experiments. We suggest that indeed the negative resistance has a big influence on the experimental results.

Index Terms—THz oscillator, negative resistance, BSCCO

I. INTRODUCTION

THz emission from intrinsic Josephson junctions of the BSCCO type has received much attention recently. Several experiments have been reported [1]–[7], in which THz radiation emitted from BSCCO single crystals was observed. However in most cases the detected power is rather small, or the frequency is rather low, or the emitted radiation is detected indirectly in an on-chip detector. It has also been demonstrated that a BSCCO single crystal is a (stacked) Josephson junction with ac Josephson effect even at frequencies as high as 2 THz [8]. Recently a very convincing experiment with THz emission was reported [9], [10] and it has attracted a lot of focus on THz emission, as well as renewed experimental efforts.

II. THE MODEL

Parallel to the experimental work there has been theoretical/numerical work on fluxon dynamics in layered superconductors of the BSCCO type [11]–[14]. The calculations demonstrate that the best way to obtain THz radiation is by having in phase motion of the fluxons in the different layers. Typically - both theoretically and experimentally - it has been assumed that the best way to obtain that is by having flux flow generated by a magnetic field applied parallel to the a-b plane or by coupling the BSCCO sample to a cavity [15], [16]. The successful experiment in [9], [10] was done without a magnetic field, and it was suggested that an internal cavity related to so called Fiske steps [17] played a major role in the THz generation.

In view of the recently reported experiment on THz generation [9], [10] where at least some of the experimental observations are still somewhat puzzling, we suggest here a new way of interpreting the THz emission from a BSCCO single crystal. The experimental observation of THz emission seem to have two different conditions: (i) the radiation is

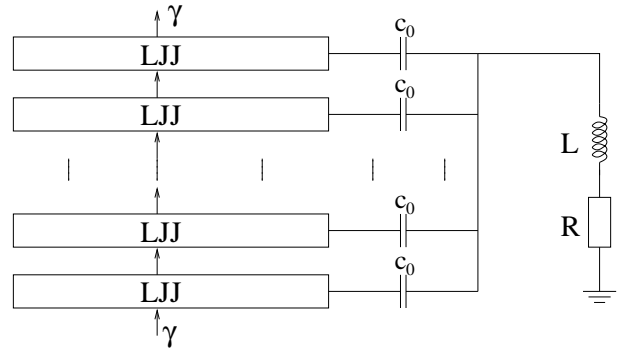

Fig. 1. A simplified drawing of a BSCCO single crystal coupled to cavity.

connected with (internal Fiske) resonances, or (ii) with a negative differential resistance near the energy gap - due to heating. The two mechanisms may be described as follows: The increase of the bias current near the energy gap gives rise to heating, and the energy gap decreases with the higher temperature. The result is a back bending IV curve resulting in a negative differential resistance. The second mechanism for THz radiation involves the Josephson junctions in the stack coupled to an internal (Fiske) resonance. In the following we will describe in a simplified way the fluxon dynamics.

A simplified drawing of a BSCCO single crystal in a cavity is shown in Fig. 1 [15], [16]. The individual long Josephson junctions are inductively coupled to each other and also coupled to the cavity [15], [16]. Thus there is a competition between the junction - junction coupling and the junction - cavity coupling. The mechanism of the junction - cavity coupling is the following: Fluxons in the junctions move back and forth driven by the bias current. Fluxons in neighboring junctions are repulsive, typically leading to anti-phase motion of the fluxons in the different junctions. Each time a fluxon hits the boundary to the cavity it injects a (small) amount of charge as input to the cavity. If the fluxon shuttling frequency is close to the cavity resonance frequency, a strong cavity current gradually builds up. In the steady state, the cavity interacts back on the junctions through current injection, and thus the cavity current will tend to lock all the fluxons to the same (cavity resonance) frequency. The cavity thus provides a force which perturbs the initial anti-phase motion, and may even force the fluxons to perform in-phase motion at the cavity resonance frequency [15], [16]. The stack-cavity system with in-phase fluxon motion may be utilized as a THz oscillator. It is difficult experimentally to obtain a sufficiently strong coupling to an external cavity, however the Fiske resonances are internal to the junction, and gives a strong interaction, that

Manuscript received August 17, 2008. Stimulating discussions with K.Kadowaki, U. Welp, X.Hu and Zhiseng Lin are greatly acknowledged.

N. F. Pedersen is with Oersted-DTU, Section of Electric Power Engineering, The Technical University of Denmark, DK-2800 Kgs. Lyngby, Denmark. S. Madsen is with the Department of Chemistry, University of Aarhus, DK-8000 Aarhus, Denmark

may even be seen in the IV-curve [17]. The Fiske resonances are linear and obey the condition

$$\Omega = n\pi u/2L \quad , \quad n = 2, 4, 6, \dots \quad (1)$$

where L is the junction length in the direction of fluxon motion. For junction lengths of order tens of micrometers the Fiske resonances may be of order GHz or even THz. If a magnetic field is applied, the symmetry is broken and resonances with $n = 1, 2, 3, \dots$ will also be excited [17] and visible in the IV - curve. Here u is the Swihart velocity corresponding to the excited mode.

Radiation emission at microwave frequencies may be obtained in several ways. By applying a large magnetic field, a unidirectional flux flow is obtained, and electromagnetic radiation is emitted where the fluxons leave the long Josephson junction [18], [19]. Here we are interested in the situation without a magnetic field, but with the stacked junction interacting with a cavity. The Fiske mode excitations exist at equidistant voltages according to Eq. (1). Near a resonance - and if the impedance mismatch to the wave guide or free space is not too big - we can expect conditions for emission to be favorable and THz radiation may be observed. In a first approximation the amount of radiation may be estimated by the impedance mismatch and the classical formula for the transmission coefficient [20]

$$T = \frac{4Z_1Z_2}{(Z_1 + Z_2)^2} \quad , \quad (2)$$

where Z_1 and Z_2 are the impedances of the waveguide (possibly free space) and the junction, respectively. Typically in experiments the measured emission is only a few percent of the available power in the junction due to impedance mismatch.

In the recent THz emission paper [9], [10] radiation close to Fiske resonances was measured in general agreement with the discussion above. Below we will show that near the resonances we may get a region of negative differential resistance. It is well known that for BSCCO the IV-curve may bend back close to the energy gap [4], [9], [10] giving rise to a negative differential resistance. In both of these cited experiments [4], [9], [10] radiation with bias on the negative differential resistance part was also observed. Such a negative differential has been observed by many authors and is believed to be due to heating. In the next section we will discuss the consequences of a negative differential resistance.

III. NEGATIVE DIFFERENTIAL RESISTANCE

As is well known a resistance causes dissipation. If the resistance is negative it will lead to emission. Recently there has been a renewed interest in negative resistance phenomena in Josephson junctions [21], [22] as well as semiconductor based THz emission systems [23].

Negative differential resistance in a Josephson junction can be obtained in several ways:

- (i) Applying a (large) microwave signal (half harmonic generation, Josephson parametric amplifiers) [24]–[26].

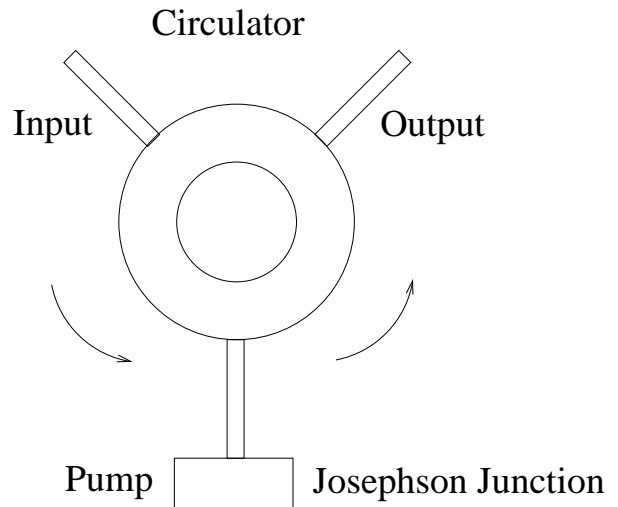

Fig. 2. Josephson junction reflection parametric amplifier.

- (ii) backbending IV-curve due to heating in BSCCO [4], [9], [10].
- (iii) Josephson junction coupled to a cavity.
- (iv) in general a non-linear IV-curve due to some strong interaction with other junctions or surroundings.

A Josephson junction reflection parametric amplifier [27], [28] utilizes the negative input resistance obtained by a pump signal at the threshold of half harmonic generation. Fig. 2 shows the principle of a negative resistance reflection amplifier with a circulator. A signal together with unavoidable thermal noise is applied to the input line, where it is directed to the junction mounted in the second arm of the circulator. The reflected signal from the junction goes to the third arm of the circulator, the output line. The reflected signal is determined by the reflection coefficient Γ [20],

$$\Gamma = \frac{(Z_1 - Z_2)^2}{(Z_1 + Z_2)^2} \quad . \quad (3)$$

Here Z_1 is the waveguide characteristic impedance, R_1 and $Z_2 = R_2 + jX_2$ is the Josephson junction input impedance. If R_2 is negative as discussed above, and $X_2 = 0$ (at resonance) we find that the reflection coefficient, Γ , becomes larger than one,

$$\Gamma = \frac{(|R_1| + |R_2|)^2}{(|R_1| - |R_2|)^2} > 1 \quad , \quad (4)$$

i.e. the input signal is amplified to a larger output signal. In experiments on the negative resistance parametric amplifier [27], [28] it was found that the negative resistance could cause a large amplification of signal as well as the noise, as long as both were in the frequency window (band width) where the input resistance was negative. Even without a signal the amplified noise gave rise to a huge emission due to the noise interacting with the negative resistance. This so-called “noise rise” was the subject of numerous studies [29], [30] but never fully understood.

Fig. 3 shows schematically the negative resistance part of a BSCCO junction similar to that in [9], [10]. Also shown is

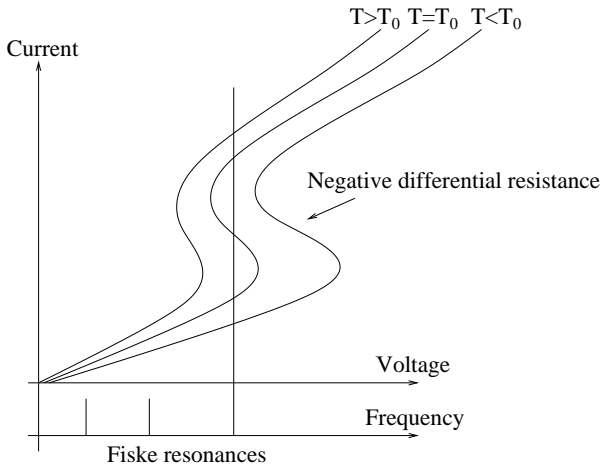

Fig. 3. Qualitative temperature behavior for the negative resistance part of the BSCCO IV curve

schematically the position of the Fiske resonances. According to the previous discussion there is a possibility that the negative resistance together with the Fiske resonance will lead to amplification of whatever frequency components (Josephson oscillations, harmonics, cavity enhanced oscillations as well as noise) are present in the negative input impedance window. The result of this amplification is a large emission signal particularly if the negative impedance is not very different from free space or waveguide impedance, Eq. (3).

In [9], [10] it was noted that the temperature dependence of the emission was quite unusual. The emission was found in a rather narrow temperature range. Both above and below this temperature range the emission disappeared. This is consistent with Fig. 3, where the qualitative behavior of the IV curve for higher and lower temperatures are shown. We note in Fig. 3, that at $T=T_0$ the negative differential resistance coexist with the Fiske resonance, where as for both $T>T_0$ and $T<T_0$ this coexistence is not present.

We note that emission of electromagnetic radiation corresponding to this negative differential resistance was also observed in the experiment by Lee et al. [4].

In [9], [10] there was also observed emission at Fiske resonances well below the gap. This is apparently not consistent with the negative impedance picture discussed in the previous section. However Fig. 4 demonstrates that together with a cavity resonance we also find a negative differential resistance in the IV curve. The combination of the Josephson junction McCumber curve and a cavity resonance curve leads to a negative differential resistance region near a Fiske resonance. Fig. 4 shows the result of a numerical as well as an analytical calculation of the IV-curve of a junction coupled to a cavity. Note that only the analytical curve has a negative differential resistance region. The numerical curve show switching instead - as would be the case in an experiment with DC current bias. However the proximity of the negative resistance region to the resonance may possibly influence the emission. The slope of the negative resistance region in the IV curve relative to the slope of the load line is important for negative resistance emission. Thus we suggest that even for the low voltage part

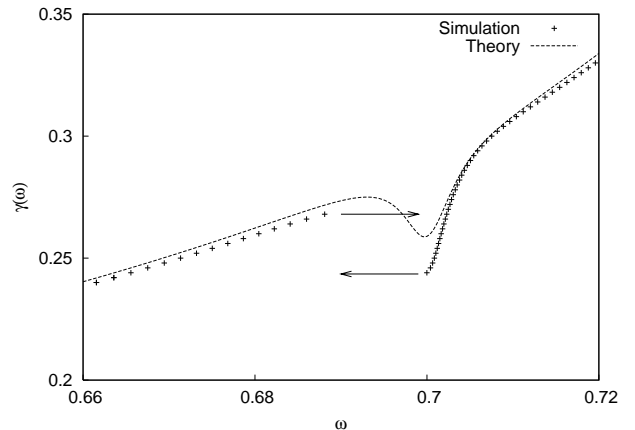

Fig. 4. Numerical and analytical IV curves for a single Josephson junction. Note that only the analytical part has a negative resistance region. The numerical curve shows switching instead.

of the IV curve with Fiske steps in [9], [10], emissions may possibly be explained by a negative resistance in the IV curve and a reflection coefficient larger than one. If so it may be difficult to distinguish the present interpretation from a more conventional one.

IV. CONCLUSION

We have proposed that the recent THz emission may be explained in terms of a negative differential resistance region connected with the back bending IV curve near the energy gap. Possibly the emission near the Fiske resonances may also be partly due to a negative resistance region.

REFERENCES

- [1] G. Hechtfisher, R. Kleiner, A. V. Ustinov, and P. Muller, "Non-Josephson Emission from Intrinsic Junctions in $\text{Bi}_2\text{Sr}_2\text{CaCu}_2\text{O}_{8+y}$: Cherenkov Radiation by Josephson Vortices", *Phys. Rev. Lett.* vol. 79, pp. 1365, 1997.
- [2] E. Kume, I. Iguchi, and H. Takahashi, "On-chip spectroscopic detection of terahertz radiation emitted from a quasiparticle-injected nonequilibrium superconductor using a high- T_c Josephson junction", *Appl. Phys. Lett.*, vol. 75, pp. 2809, 1999.
- [3] M. H. Bae and H. J. Lee, "Vortex-flow electromagnetic emission in stacked intrinsic Josephson junctions", *Appl. Phys. Lett.* vol. 88, pp. 142501, 2006.
- [4] K. Lee, W. Wang, and I. Iguchi, M. Tachiki, K. Hirata, and T. Mochiku, "Josephson plasma emission from $\text{Bi}_2\text{Sr}_2\text{CaCu}_2\text{O}_y$ intrinsic junctions due to quasiparticle injection", *Phys. Rev. B*, vol. 61, pp. 3616, 2000.
- [5] I. E. Batov, X. Y. Jin, S. V. Shitov, Y. Koval, P. Muller, and A. V. Ustinov, "Detection of 0.5 THz radiation from intrinsic $\text{Bi}_2\text{Sr}_2\text{CaCu}_2\text{O}_8$ Josephson junctions", *Appl. Phys. Lett.* vol. 88, pp. 262504, 2006.
- [6] G. Hetchfisher, W. Walkenhorst, G. Kunkel, K. Schlenga, R. Kleriner, P. Müller, "High frequency applications of intrinsic Josephson junctions in mesa structures on $\text{Bi}_2\text{Sr}_2\text{CaCu}_2\text{O}_{8+y}$ single crystals", *IEEE Trans. Appl. Supercond.*, vol. 7, Issue 2 part 3, pp. 2723, 1997.
- [7] K. Kadowaki, I. Kakeya, T. Yamamoto, T. Yamazaki, M. Kohri, and Y. Kubo, "Dynamical properties of intrinsic Josephson vortices in mesoscopic intrinsic Josephson junctions in single crystalline $\text{Bi}_2\text{Sr}_2\text{CaCu}_2\text{O}_{8+\delta}$ ", *Physica C*, vol. 437, pp. 111, 2006.
- [8] H. B. Wang, P. H. Wu, and T. Yamashita, "Stacks of intrinsic Josephson junctions singled out from inside $\text{Bi}_2\text{Sr}_2\text{CaCu}_2\text{O}_{8+x}$ single crystals", *Appl. Phys. Lett.*, vol. 78, pp. 4010, 2001.
- [9] L. Ozyuzer et. al., "Emission of Coherent THz Radiation from Superconductors", *Science*, vol. 318, pp. 1291, 2007.
- [10] K. Kadowaki and U. Welp, private communication, 2008.
- [11] S. Sakai, P. Bodin, and N. F. Pedersen, "Fluxons in thin-film superconductor-insulator superlattices", *J. Appl. Phys.*, vol. 73, pp. 2411, 1993.

- [12] T. Koyama and M. Tachiki, "Plasma excitation by vortex flow", *Solid State Commun.*, vol. 96, pp. 367, 1995.
- [13] M. Tachiki, M. Iizuka, K. Minami, S. Tejima, H. Nakamura, "Emission of continuous coherent terahertz waves with tunable frequency by intrinsic Josephson junctions", *Phys. Rev. B* vol. 71, pp. 134515, 2005.
- [14] L. N. Bulaevskii and A. E. Koshelev, "Radiation from Flux Flow in Josephson Junction Structures", *J. Superconduct. Novel Magnetism*, vol. 19, pp. 349, 2006.
- [15] S. Madsen, G. Filatrella and N. F. Pedersen, "Interaction between a BSCCO-type intrinsic Josephson junction and a microwave cavity", *Euro. Phys. J. B*, vol. 40, No. 2, pp. 209, 2004.
- [16] S. Madsen, N. F. Pedersen, P. L. Christiansen, "Repulsive fluxons in a stack of Josephson junctions perturbed by a cavity", *Physica C*, vol. 468, pp. 649, 2008.
- [17] S. M. Kim, H. B. Wang, T. Hatano, S. Urayama, S. Kawakami, M. Nagao, Y. Takano, and T. Yamashita, "Fiske steps studied by flux-flow resistance oscillation in a narrow stack of $\text{Bi}_2\text{Sr}_2\text{CaCu}_2\text{O}_8$ junctions", *Phys. Rev. B*, vol. 72, pp. 140504, 2005.
- [18] V. P. Koshelets et al., "Superconducting integrated receiver for TELIS", *IEEE trans. Appl superconductivity*, vol. 15, Issue 2 part 1, pp. 960, 2005.
- [19] S. J. Kim, T. Hatano, and M. Blamire, "Flux-flow behaviors on a $\text{Bi}_2\text{Sr}_2\text{CaCu}_2\text{O}_8$ +Bi-2212 stack", *J. Appl. Phys.*, vol. 103, pp. 07C716, 2008.
- [20] J.A. Stratton, *Electromagnetic theory*. McGraw-Hill, New York and London 1941.
- [21] J. Nagel, D. Speer, T. Gaber, A. Sterck, R. Eichhorn, P. Reimann, K. Ilin, M. Siegel, D. Koelle and R. Kleiner, "Observation of Negative Absolute Resistance in a Josephson Junction", *Phys. Rev. Lett.*, vol. 100, pp. 217001, 2008.
- [22] M. Kostur, L. Machura, P. Talkner, P. Hnggi, and J. Luczka, "Anomalous transport in biased ac-driven Josephson junctions: Negative conductances", *Phys. Rev. B*, vol. 77, pp. 104509, 2008.
- [23] T. Hyart, K. N. Alekseev, and E. V. Thuneberg, "Bloch gain in dc-ac-driven semiconductor superlattices in the absence of electric domains", *Phys. Rev. B*, vol. 77, pp. 165330, 2008.
- [24] N. F. Pedersen, M. R. Samuelsen, and K. Saermark, "Parametric Excitation of Plasma Oscillations in Josephson Junctions", *J. Appl. Phys.*, vol. 44, pp. 5120, 1973.
- [25] N.F. Pedersen, "Zero-Voltage Non-Degenerate Parametric Mode in Josephson Tunnel Junctions", *J. Appl. Phys.*, vol. 47, pp. 696, 1976.
- [26] N. F. Pedersen and S. Sakai, "Prediction of half harmonic generation in stacked Josephson junctions and $\text{Bi}_2\text{Sr}_2\text{CaCu}_2\text{O}_x$ single crystals", *Phys. Rev. B*, vol 61, pp. 11328, 2000.
- [27] J. Mygind, N. F. Pedersen, and O. H. Soerensen, "X-band singly degenerate parametric amplification in a Josephson tunnel junction", *Appl. Phys. Lett.*, vol. 32, pp. 70, 1978.
- [28] M. J. Feldman, P. T. Parrish, and R. Y. Chiao, "Parametric amplification by unbiased Josephson junctions", *J. Appl. Phys.*, vol. 46, pp. 4031, 1975.
- [29] P. Bryant, K. Wiesenfeld, and B. Mcnamara, "The nonlinear effects of noise on parametric amplification: An analysis of noise rise in Josephson junctions and other systems", *J. Appl. Phys.*, vol. 62, pp. 2898, 1987.
- [30] R. D. Miracky and J. Clarke, "Simulation of the noise rise in three-photon Josephson parametric amplifiers", *Appl. Phys. Lett.*, vol. 43, pp. 508, 1983.